

TRIMLINE INSTALLATION INSTRUCTIONS
TRIMLINE INSTALLATIE VOORSCHRIFT
TRIMLINE INSTRUCTIONS DE INSTALLATION
TRIMLINE INSTALLATIONSVEJLEDNING
TRIMLINE INSTRUCCIONES DE INSTALACIÓN
TRIMLINE MONTAGEANLEITUNGEN

Trimline 6345 Panorama/Corner	(1053/ 1054/1055)
Trimline 3863 Panorama/Corner/Front	(1070/1071/1072/1073)
Trimline 6345 Panorama/Hoek	(1053/ 1054/1055)
Trimline 3863 Panorama/Hoek/Front	(1070/1071/1072/1073)
Trimline 6345 Panorama/Coin	(1053/ 1054/1055)
Trimline 3863 Panorama/Coin /Frontal	(1070/1071/1072/1073)
Trimline 6345 Panorama/Hjørne	(1053/ 1054/1055)
Trimline 3863 Panorama/Hjørne/Front	(1070/1071/1072/1073)
Trimline 6345 Panorama/Ángulo	(1053/ 1054/1055)
Trimline 3863 Panorama/Ángulo/Frente	(1070/1071/1072/1073)
Trimline 6345 Panorama/Ecke	(1053/1054/1055)
Trimline 3863 Panorama/Ecke/Front	(1070/1071/1072/1073)

INSTALLATION INSTRUCTIONS

Trimline assortment

Trimline 6345 Panorama/Corner (1053/ 1054/1055)

Trimline 3863 Panorama/Corner/Front (1070/1071/1072/1073)

IRELAND-IE

UNITED KINGDOM-UK

TABLE OF CONTENTS

1. INSTALLATION INSTRUCTIONS	Page. 3
1.1 General instructions	
2. PLACING THE APPLIANCE	Page. 4
2.1 Connection the gas lines	
2.2 Preparation and installation	
2.3 Installing gas control GV60	
3. PLACING OPTIONAL CERAMIC LOG AND OPTIONAL PEBBLES SET	Page. 6
3.1 Fitting the ceramic logs	
3.1 Fitting the optional pebbles set	
4. TECHNICAL DETAILS GV60	Page. 7
5. INSTRUCTIONS FOR MERTIK MAXITROL GV60 GASCONTROL	Page. 8
6. GAS TECHNICAL DATA	Page. 9
7. CONCENTRIC CHIMNEY LAY OUT	Page. 10
8. CONCENTRIC FLUE SYSTEM	Page. 11
8.1 Components of the concentric flue system	
8.2 Construction of concentric flue system	
8.3 Installation instructions regarding existing flues	
8.4 Components	
8.5 Installation	
8.6 Cleaning and maintenance	
9. TERMINAL POSITIONS AND CORRECT FUNCTIONING	Page. 13
10. CLEANING AN MAINTENANCE	Page. 14
11. TROUBLESHOOTING LIST MERTIK GV60	Page. 15
APPENDIX1	DIMENSIONAL DRAWINGS
APPENDIX2	INSTALLATION EXAMPLES
APPENDIX3	INSTALLATION INSTRUCTIONS REGARDING FLUES
APPENDIX4	EXPLODED VIEW AND SPARE PARTS
APPENDIX5	PREPARATIONS AND INSTALLATION
APPENDIX6	MAKING GAS CASSETE GV60 READY FOR INSTALLATION
APPENDIX7	FITTING THE LOG SET
APPENDIX 8	FITTING THE OPTIONAL PEBBLES SET

1. INSTALLATION INSTRUCTIONS

NOTICE

The installation should be performed only by an authorized gasfitter

1.1 General instructions

- * The gas fireplace must be installed, connected and inspected as a balanced flue fire by a qualified fitter, according to national, regional, and local standards and regulations.
- * The flue system and the terminals in the outer wall or roof face must also meet the requirements outlined in the applicable standards and regulations.
- * The temperature of the walls and shelves near the side and back of the unit may not be more than 80°C higher than the temperature of the environment.
- * The unit has been approved in combination with the THC CC Ø100 mm - Ø150 mm in accordance with European CE standards for gas fires, and may therefore only be applied with this system.
- * The product needs to be serviced and inspected by the fitter for local gas distribution as indicated on the identification plate.
- * The instructions are only applicable if the relevant country code is stated on the unit. If this is not the case, the gas technical information for the relevant country needs to be consulted and modifications discussed with the manufacturer.
- * There will be air in the gas pipes when the unit is first used. The gas pipes therefore need to be purged first.
- * Ignite the fire according to operating instructions and check whether the burner flame is uniform. After the unit has been used for the first time, you should remove any deposits resulting from Running/burning in the paint, using a glass cleaner for heaters.
- Distance to flammable materials:**
- * With respect to the front, side and top of the unit, a distance of 1200 mm needs to be kept between the unit and: curtains, floor covering, upholstery and fabrics, and/or other flammable material unless stated other wise in these instructions.
- Distance to non-flammable materials:**
- * The unit needs to be placed a minimum distance of 25 mm from the wall unless stated otherwise in these instructions.



WARNING

Gas fires become hot when they are in operation. After installing the appliance the glass surface is considered active zone. The glass surface can become very hot.!

Attention! Accordingly, care should be taken, for example children and needy in the vicinity of burning fires are banned. Gas fires must not be on or against flammable materials are placed (curtains etc.).

Never install the unit against or within a flammable wall!.

NOTICE

Construction material for fireplaces and mantles etc. or built-in situation, must be made of non-combustible material. This also applies to floors and ceilings. Never use flammable materials near the unit in compliance with the above requirements.

If in doubt, consult your dealer

2. PLACING THE APPLIANCE

NOTICE

Before installing the device it is recommended to first read Chapter 9 "Concentric flue system"

2.1 Connection the gas lines

You can determine where the gas pipes will be placed, depending on the positioning of the appliance. Ensure control equipment is not twisted during installation and there is no excessive tension. Accessibility of various connection points in relation to components need to be maintained. After installation, check the connections for gas leakage. Use a 3/8" gas tap in the main gas supply.

Ensure the gas pipes are dirt-and sand-free. The gas connection should only be done without any excessive tension in the tubes etc. This prevents any damage occurring to the gas control equipment.

2.2 Preparation and installation (see APPENDIX 5)

- * Remove the packaging and check the unit for possible damage.
- * Please note: place the unit on a stable surface. **Attention;** Do not place the unit on its back/side!
- * Place the unit at the installation location
- * you can use the lifting brackets supplied with each appliance(1).
- * The window should now be removed in order to take the additional parts out of the unit.
- * Remove the decorative frame on the bottom side of the window.
- * Loosen the screws holding the bottom and top glass holders (2).
- * Place the suction cup (s) in the middle of the glass-panel and remove the panel by GENTLY moving this first upwards and then the lower edge of the panel very carefully and slowly pulling toward you (3 and 4). Then place in a safe place where the window can not be broken or damaged. If the removed glass panel shown damage (scratches and / or damaged edges) do not use the glass panel and alerting the supplier.
- * Next, take all the packaged components out of the unit and check to make sure they are not damaged or broken.
- * Situate the unit (see APPENDIX3 as an example of an installation location) in your chosen installation location. The device must be attached directly to the rear wall (mounting material not included) (5).
- * The legs of the device can be adjusted. (Min 280 Max 460) (5)
- * The adjustable feet allow to adjust the device more refined.
- * Build the gas cassette in the self-assessed surround/casing. The distance between the gas cassette and the unit is determined by the cable lengths of which control cabinet to the pilot burner and the gas control etc. Max.1500 mm. Before building in the gas cassette first install the gas control inside, see 2.3.
- * Install the supplied convection grilles at least 50 cm below the ceiling (see APPENDIX 2) on the appropriate wall. A lowered ceiling inside the whole structure could be a possible solution in the event of a very high space inside this structure.

NOTICE

Temperature of the exhaust grilles could reach over 100 ° C. Caution is therefore needed.

2.3 Installing gas control GV60 (see APPENDIX 6)

The complete gas control is fitted under the gas unit. The gas valve including the burner control must be fitted by the installer in the gas cassette. The step by step procedure:

- * After the window is taken away and parts inside the gas fire are taken out; place the complete gas fire carefully on the backside(1). You can use the wooden pallet to support the gas fire.
- * Cut the binders and CAREFULLY loosen and unroll the various lines and cables (2).
- * Remove the screw holding gas valve bracket (3) and carefully take away the gas valve and move it to the side of the gas fire where you want to install the gas cassette
- * Install the Gas valve + bracket inside the gas cassette, and secure it with the two winged nuts at the position as indicated (4,5,6).
- * Place the entire gas cassette into the surround/casing of the gas fireplace. Be aware of the maximum distance between gas fire and gas cassette limited by the length of thermocouple etc.(7)
- * Make sure the tubes, ignition cable and thermocouple without tension and sharp bends provided, this must be avoided at all times. Make sure the spark plug cable is free from metal parts (8).

3. PLACING OPTIONAL CERAMIC LOG AND OPTIONAL PEBBLES SET

3.1 Fitting the Ceramic log set (see APPENDIX7)

- * Mix the glowing material (lava granules) and spread them evenly over the burner and the burner plate so that they are just covered. Glowing embers can be placed here and there as decoration.
- * Place the ceramic wood blocks in the correct order as shown on **APPENDIX 7**.
- * Place the logs carefully. Other location can seriously affect the flames or malfunction of the burn process (sooting)
- * Before replacing the windows make sure if there must be a restriction plate to be placed or not. See chapter 7 "**Concentric chimney lay out**"
- * If there is a restriction required for your situation, remove the baffle plate by unscrewing it from the front of the plate and move the plate backwards and then out. Now install the restriction plate with two screws and replace the baffle plate. (Also see **APPENDIX 5-7**).
- * Now place the window in reverse order as described at chapter "**PLACING THE APPLIANCE**" 2.2 and on **APPENDIX 5**.

Note: when installing the log and Pebble set and the various glowing materials and accessories, the following must be taken into account:

A: No glowing material in or on the pilot burner.

B: Prevent that ceramic material falls on the glass seals. Remove this if necessary. The window can be damaged.

C: *Slot /opening between burner and mesh deco plate must be kept free of glowing material. Too much placed glowing material can affect the combustion process.*

3.2 Fitting the optional Pebble set. (see appendix 8)

- * Scatter vermiculite evenly over the burner tray. Make sure the pilot light remains unobstructed.
- * Place a row of medium-sized and large pebbles at the front of the burner plate
- * Fill the burner tray with small and medium-sized pebbles from the front to the rear. Place the pebbles as closely as possible to each other on the burner tray.
- * Fill the rear of the burner plate with medium-sized and large pebbles.
- * Before replacing the window make sure if there must be a restriction plate to be placed or not. See chapter 7 "**Concentric chimney lay out**"
- * If there is a restriction required for your situation, remove the baffle plate by unscrewing it from the front of the plate and move the plate backwards and then out. Now install the restriction plate with two screws and replace the baffle plate. (Also see **Appendix 5**, pictures 7).
- * Now place the window in reverse order as described at chapter "**PLACING THE APPLIANCE**" 2.2 and on **Appendix 5**.

NOTICE

MAKE SURE THE PILOT LIGHT REMAINS UNOBSTRUCTED FROM ANY MATERIAL!

4. TECHNICAL DETAILS GV60

Gas valve type : Mertik GV60
 Burner control : B6R R8U
 Ignition : Remote control operation and Piezo ignition
 Gas connection : 3/8 "(External) **A** = Gas inlet **B** = Gas outlet
C = Thermocouple connection
D = pilot burner connection

Unit category : C11-C31-C91
 Pilot flame : SIT 3 flames
 Combustion gas discharge and Combustion air supply : Concentric: Ø100 / 150mm

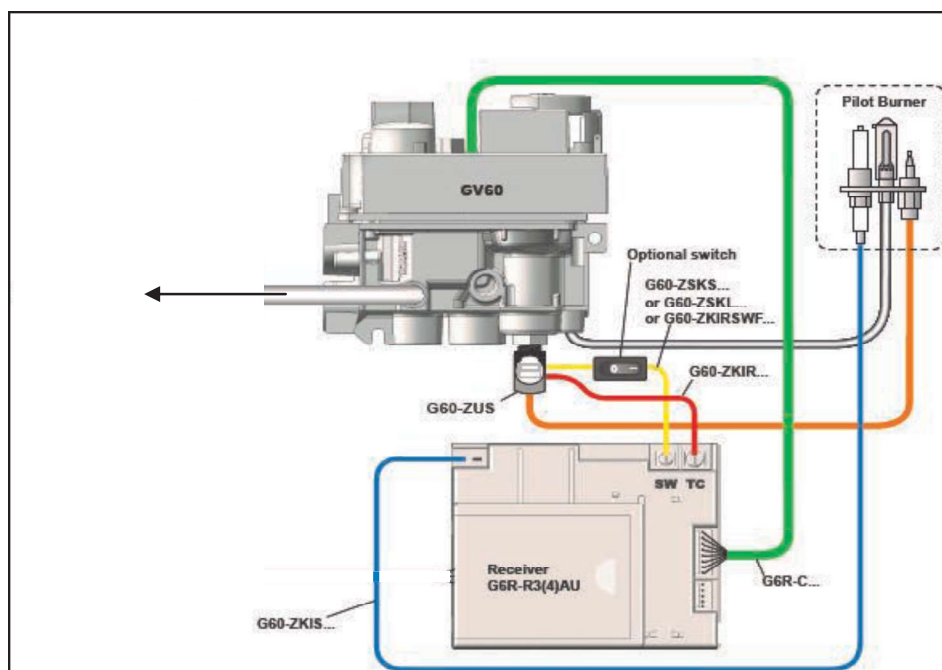
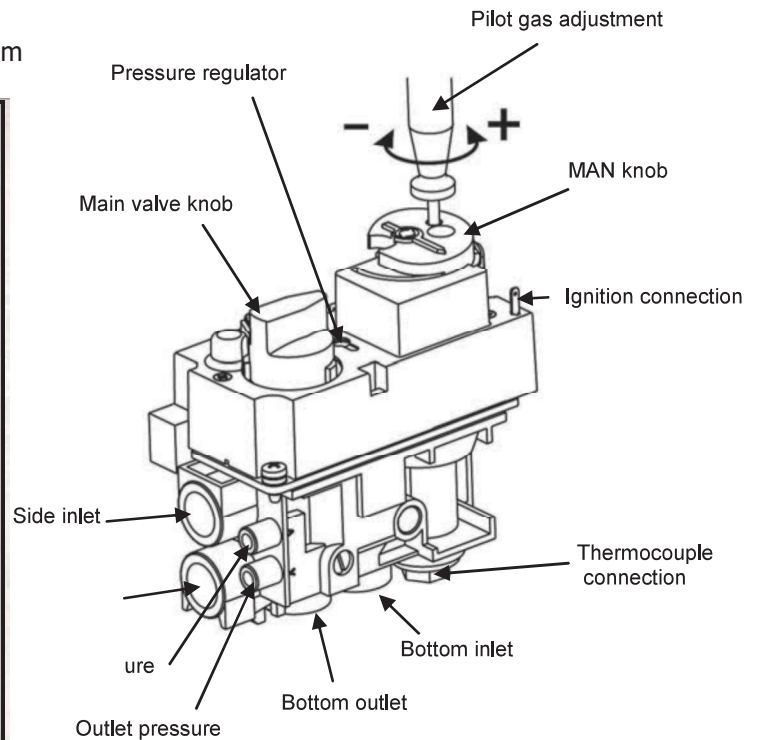
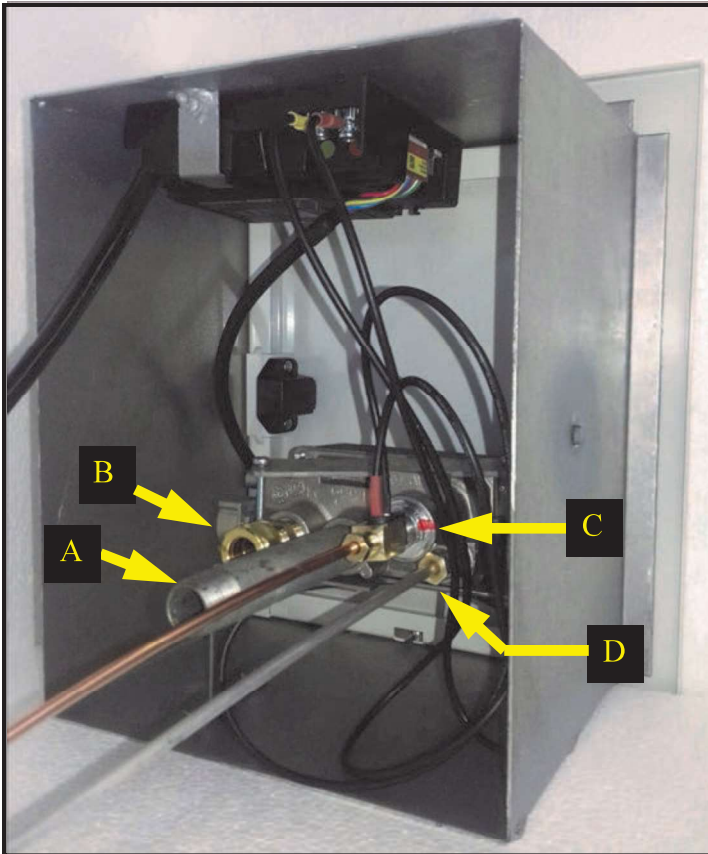

NOTICE

SEALED PARTS MAY NOT BE ADJUSTED.

5. INSTRUCTIONS FOR MERTIK MAXITROL GV60 GASCONTROL

WARNING

It is forbidden to start up the unit if window (s) is not present or broken!

Ensure that the fuel supplied to the unit is clean and free from particles and moisture.

Before a gas supply pipe (new or existing) is connected to the main gas pipe at the gas meter and to the gas control block of the unit, clean and dry compressed air should be blown through it.

Cut copper pipes as well as aluminium pilot pipes must be deburred and blown clean before they are connected. The dust filter at the connection to the gas control block will only filter out the coarsest dirt from the system. Fine particles are still able to reach the inside and may damage and/or adversely affect regulation in the gas control block .

Heat, moisture and dust are a threat to all electronic components

Protect the electronic gas control *until* all construction, plastering and paintwork has been completed.

If such work cannot be avoided, then protect the control against dirt and moisture penetration by using, for example, plastic film .

WARNING

Electronic components will become permanently faulty when exposed to temperatures higher than 60°C. Standard AA batteries will crack open at temperatures >54°C and the battery contents will damage the electronic switches located underneath. Batteries last longest at <25°C. At >50°C the life span is around 23 weeks, this makes the use of the gas fire unnecessarily expensive.

Only install the gas control block and receiver as pre-installed at the factory

Remember that components may have to be replaced or that repairs may have to be performed at a later date. This may be more difficult if the control is installed using a method that is different from the instructions provided here.

Only place the batteries *after* wiring to the receiver, gas control block and pilot set is connected.

Premature connection to the energy source may damage the control's CPU (central processor).

Ensure that the ignition cable is not near the antenna wire and that they do not cross each other.

The high voltage released at ignition may damage the sensitive receiver circuit.

This may mean that the unit becomes less responsive or not responsive at all to handset commands.

NOTICE

Do not tighten the contact breaker and the thermocouple connection too tightly on the gas control block or to each other. It is sufficient to tighten by hand and add a half a turn with an open-end spanner.

Tightening too much will break the connection to the magnetic coil below and/or the insulation around the aluminium contact pin in the contact breaker. This may lead to the magnetic coil not opening the gas supply to the pilot and the unit not working.

Extend the supplied thermocouple with just the original extension. (available from your supplier)

Unauthorized extension of the thermocouple has the effect of stress reduction, thereby the magnetic coil can not be activated.

Prevent leakage of the ignition spark to other parts of the installation than the Ignition by the pilot

Keep the ignition free of hull or other metal parts. If cable extension is used, see to it that connections are additionally insulated with silicone grommet.

For automatic start via the transmitter, the receiver and the control the gas control valve to be switched

The oval disk on the gas control block should be turned to the ON position. The **I/O** switch should be set to "I". The ignition must be connected to the receiver box at the terminal **SPARK**.

The transmitter's contains the thermostat sensor system

The transmitter operates best at 2 to 3 m from the unit. Although the communication via short wave radio signals takes place, it is recommended that the transmitter in the 'visibility' of to lay the gas apparatus in a place where the user wants to experience a pleasant temperature. Place the hand transmitter in direct sunlight or other hot places. The thermostat measures the temperature and regulates the flame size of the gas in accordance.

Remove batteries only with the red ribbon which is under the battery, not with metal tool

Removing batteries with a metal object, the electronic control can permanently damage.

NOTICE

SEALED PARTS MAY NOT BE ADJUSTED.

6. GAS TECHNICAL DATA

		1053/54/55	1053/54/55	1053/54/55
GASTYPE		G20	G30/31	G25
COUNTRY		NO/ES/PT/DE/IE/ GB/BE/FR/IT/LV/ SI/SK/EE/HU/LT	ES/PT/IE/GB/BE/ FR/LV/SI/EE/HU/ LT/PL/CY/MT	NL/DE
CATEGORY		I2H/I2E/I2E+	I3B/P, I3+	I2L/I2ELL
PRIMARY AIR		1xØ10 1xØ7	3XØ16	1xØ10
PRE PRESSURE	mBar	20 mbar	30/50, 29/37 mbar	25/20 mbar
BURNERPRESSURE HIGH	mBar	19,2	28,5/36,3	24/ 19,2
BURNERPRESSURE LOW	mBar	5,5	9,2	2,5
INJECTOR SIZE	Ø mm	2,20	1,40	2,50
INJ. PILOTBURNER	CODE	51	30	51
LOWSETTING SIZE	mm	1,70	1,40	1,70
LOAD Hs	kW	9,3	8,7/7,9	8,8/7,9
LOAD Hi	kW	8,4	8/7,3	7,9/ 7,1
CONSUMPTION	m3/h	0,9	0,236	0,7/0,65
NOM.POWER	kW	6,9	6/5,5	6,1/5,5

		1070/1071/1072- 1073	1070/1071/1072/ 1073	1070/1071/1072/ 1073
GASTYPE		G20	G25	G30/31
COUNTRY		NO/ES/PT/DE/IE/ GB/BE/FR/IT/LV/ SI/SK/EE/HU/LT	NL/DE/BE	NL/NO/DE/ES/PT /IE/GB/BE/FR/LV/ SI/EE/HU/LT/PL/ CY/MT/IT
CATEGORY		I2H/I2E/I2E+	I2ELL/I2L	I3B/P/I3+
PRIMARY AIR		Open Ø 11	Open Ø 11	Open Ø 16
PRE PRESSURE	mBar	20 mbar	20/25 mbar	(28/30) /37 mbar
BURNERPRESSURE HIGH	mBar	13,2	13,8	23,7/30,5
BURNERPRESSURE LOW	mBar	5,8	4,5/5,3	12,1/15,5
INJECTOR SIZE	Ø mm	2,10	2,30	1,3
INJ. PILOTBURNER	CODE	51	51	30
LOWSETTING SIZE	mm	1,70	1,70	1,3
LOAD Hs	kW	7,10	6,7/7,4	7,34/7,2
LOAD Hi	kW	6,40	6,13/6,7	6,7/6,6
CONSUMPTION	m3/h	0,677	0,75/0,82	0,21/0,27
NOM.POWER	kW	5,33	4,4/4,94	4,8/4,7

Appliance has NoX Class 5

AT	I2H, I3B/P	BE	I2E+, I3+	DK	I2H, I3B/P	DE	I2ELL, I3B/P
FI	I2H, I3B/P	FR	I2E+, I3+	GR	I2H, I3B/P	GB	I2H, I3+
IS	I3B/P	IE	I2H, I3+	IT	I2H, I3+	LU	I2E, I3B/P
NL	I2L, I3B/P	NO	I3B/P	PT	I2H, I3+	ES	I2H, I3+
SE	I2H, I3B/P	CY	I3B/P, I3+	EE	I2H, I3B/P	LT	I2H, I3B/P
LV	I2H, I3B/P	MT	I3B/P	HU	I2H, I3B/P	PL	I3B/P
SI	I2H, I3B/P	SK	I2H	TR	I2H, I3B/P		

7. CONCENTRIC CHIMNEY LAY OUT

Table of concentric pathways

Pathway	Illustration	X total in metres		Y total in metres		Restriction	
		min*	max*	min*	max*	1053-1054-1055	1070-1071-1072-1073
Indirect exterior wall outlet	A-B	1	3	0	3	Remove Baffle plate !	Remove Baffle plate !
Roof pass-through without slope	C	2	12				from 2 metres
Roof pass-through with 45° slope**	D	3	12	0	4		from 2 metres
Roof pass-through with 90° slope***	E	1	12	0	2		from 2 metres

45° bend: calculation length 1 metre

90° bend: calculation length 2 metres

* lengte exclusief dak -of geveluitmondingen. Altijd startlengte 1 meter aanhouden!

** Verhouding verticaal : horizontaal $X + X1 + X2 : Y \geq 2 : 1$

*** Verhouding verticaal : horizontaal $X + X1 : Y \geq 2 : 1$

Determination of restriction, unit 1053-1054-1055:

Wall pass-through - 1 metre vertical, 90° bend, max. 3 metres horizontal, remove baffle plate and no restriction.

Roof pass-through - 2 to 4 metres vertical + roof pass-through, fit 30 mm restriction plate.

Roof pass-through - 4 to 6 metres vertical + roof pass-through, fit 40 mm restriction plate.

Roof pass-through - 6 to 12 metres vertical + roof pass-through, fit 50 mm restriction plate.

Determination of restriction unit 1070-1071-1072-1073:

Wall pass-through - 90° bend, Wall pass-through, remove baffle plate and no restriction..

Caution! Only direct wall duct allowed on NG Appliances

Wall pass-through - 1 metre vertical, 90° bend, max. 3 metres horizontal, remove baffle plate and no restriction..

Roof pass-through - 2 to 5 metres vertical + roof pass-through, fit 30 mm restriction plate.

Roof pass-through - 5 to 12 meter verticaal + dakdoorvoer restrictieplaat 40 mm plaatsen.

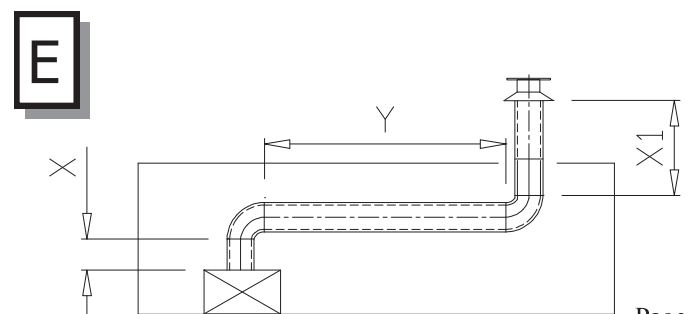
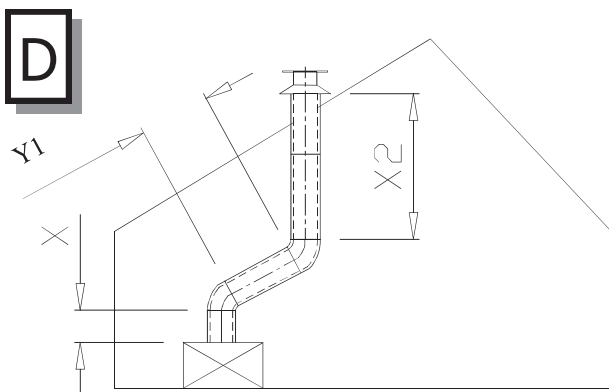
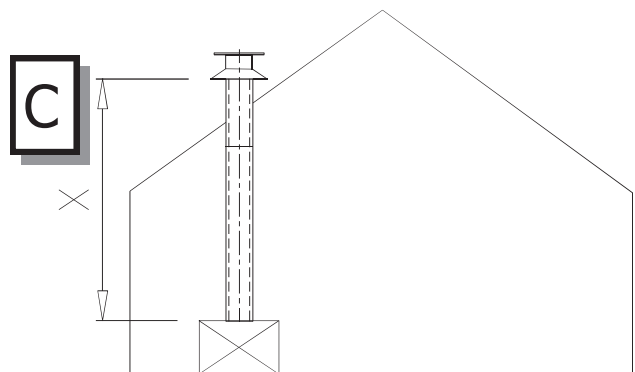
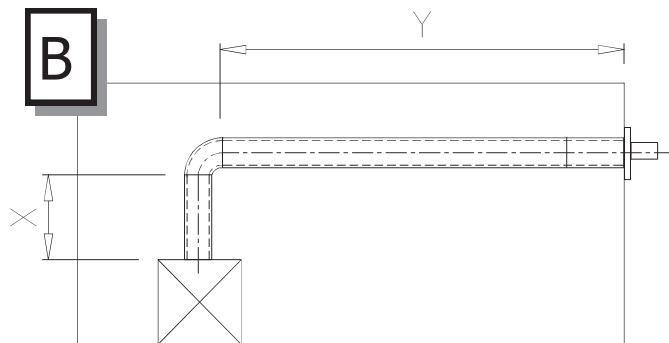
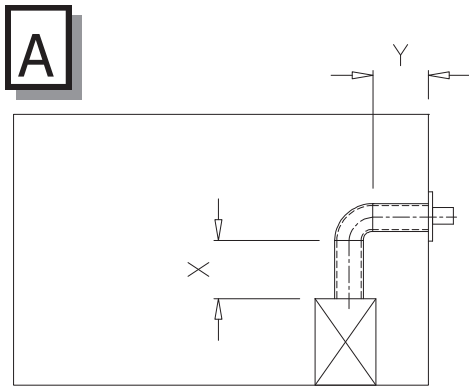

8. CONCENTRIC FLUE SYSTEM

The concentric flue system is composed of an inner- and an outer tube. These tubes are concentrically arranged; through the inner tube, the combustion gases are evacuated and the fresh combustion air is supplied between the inner and outer tube.

8.1 Components of the concentric flue system.

Different connections are possible using the concentric flue system. These are:

Through the roof face and through the exterior wall.

There are various options for mounting the lay outs for this system,

however, there are a few important requirements/conditions:

- * The maximum recommended vertical flue length is 12 metres (the sum of the flue length and the calculation lengths for the bends).
- * 90° bends have a 2-metre horizontal calculation length.
- * 45° bends have a 1-metre horizontal calculation length.
- * The outlet can be installed at any point on the roof face or exterior wall (supply and discharge in an identical pressure area), but must meet applicable regulations.
- * Ducts may not be insulated.

NOTICE

Ensure the restriction plate in the fire is mounted in the correct manner, as indicated in these instructions.

The correct restriction plate will provide the unit with the most optimal efficiency, flame image and combustion.

Mounting an incorrectly placed restriction plate may cause malfunction of the unit.

8.2 Construction of concentric flue system

Indirect wall connection.

- * The outlet may be installed in the wall, taking any hindrance to the surrounding area into consideration, according to national, regional, local standards and regulations.
Ensure wind pressure on the flue terminal is not too extreme, such as a balcony, flat roof, corners and in small alleys etc., as this may negatively influence the unit efficiency.
- * Provide a recess in the exterior wall of around 155 mm for concentric 100-150.
(in a flammable wall ensure there is 50 mm of extra space around the outer pipe and use fireproof casing) and fix the exterior wall duct with the wall plate to the outer side of the wall. The wall plate of the exterior wall duct must be sealed sufficiently against the wall on the outside, to avoid moisture and/or flue gas leaks into the living space.
- * The flue should be cased if necessary. Sufficient fireproof measures must also be taken when the flue is being mounted along flammable materials.
- * Determine the position of the unit and outlet and begin construction of the flue with the connection on the unit, paying attention to the direction of installation and connecting the elements by means of locking bands.
- * An adjustable length can be used between the bends or when connecting to the unit.
If necessary, use wall brackets to support the flue.

Rooftermination.

- * The flue terminal can be located at any random place on the roof face (supply and exhaust in identical pressure areas) and must meet the applicable rules and regulations.
- * A roof flashing for a flat roof or a lead flashing for sloping tiled roofs can be used for a watertight connection. Use various elbows for making the proper connection, if required.
The recess in the roof decking should be 5 cm larger all around, to ensure sufficient fire resistance.
- * One needs to take into account the regulation regarding fire resistance between rooms (See national, regional, local standards and regulations). A casing made of fireproof material (e.g. 12 mm Promatect fire resistant plate) must be used at 25mm from the outside duct.
- * Determine the position of the unit and outlet and begin construction of the flue with the connection on the unit (always 1 metre vertical first), paying attention to the direction of installation!
The flue must be installed dripless. Connect the elements by using locking bands.
Ensure the gas tightness of all connections is correct.
- * An adjustable length can be used between the elbows or when making the connection to the unit and/or the roof terminal. Use 2 wall brackets to support the flue on each floor.

8.3 Installation instructions regarding existing flues. (see APPENDIX 3)

Instructions

The flue gas exhaust system falls within category C91 and must be built in accordance with national rules and regulations and the instructions of the manufacturer, as specified in the documentation and installation instructions.

This means, among other things, that the existing chimney must not be smaller than 150 mm round / square, but no larger than 200 mm, and not ventilated by grilles etc. In the case of larger chimney size, a flexible hose of around 150 mm may possibly be used in combination with a flexible hose of around 100 mm, as described below. For other situations, you should consult your supplier / manufacturer.

8.4 Components

Check all parts for damage before commencing the installation. You will require the following parts for converting a brickwork duct to a balanced flue concentric duct :

Note: The renovation kit consists of parts 4, 5 and 7.

8.5 Installation

- * Guide the flexible hose (6) through the existing duct.
- * Attach the adjustable pipe (5) to the bottom of the flexible hose and secure this in place using 2 parkers.
- * Level the bottom side of the adjustable pipe (5) with the ceiling of existing chimney.
- * Shorten the flexible hose to approximately 100 mm above the existing chimney top.
- * Attach the mounting plate / connecting piece (7) to the flexible hose on the roof. Clamp it with a hose band and secure it in place using a parker.
- * Attach the mounting plate / connecting piece (7) to the chimney top, using silicone sealant to make it watertight secure with stainless steel screws.
- * Install the roof terminal (9) and secure it in place using the supplied locking band (8).
- * The adjustable pipe (5) will stick about 100mm below ceiling/existing chimney. Mount the inner ceiling plate (4) gastight to the ceiling/existing chimney with silicone kit and fixing screws.
- * Position the unit in accordance with the instructions of the unit manufacturer.
- * Always install a minimum of 1 metre of concentric duct type THC CC (2).

9. TERMINAL POSITIONS AND CORRECT FUNCTIONING

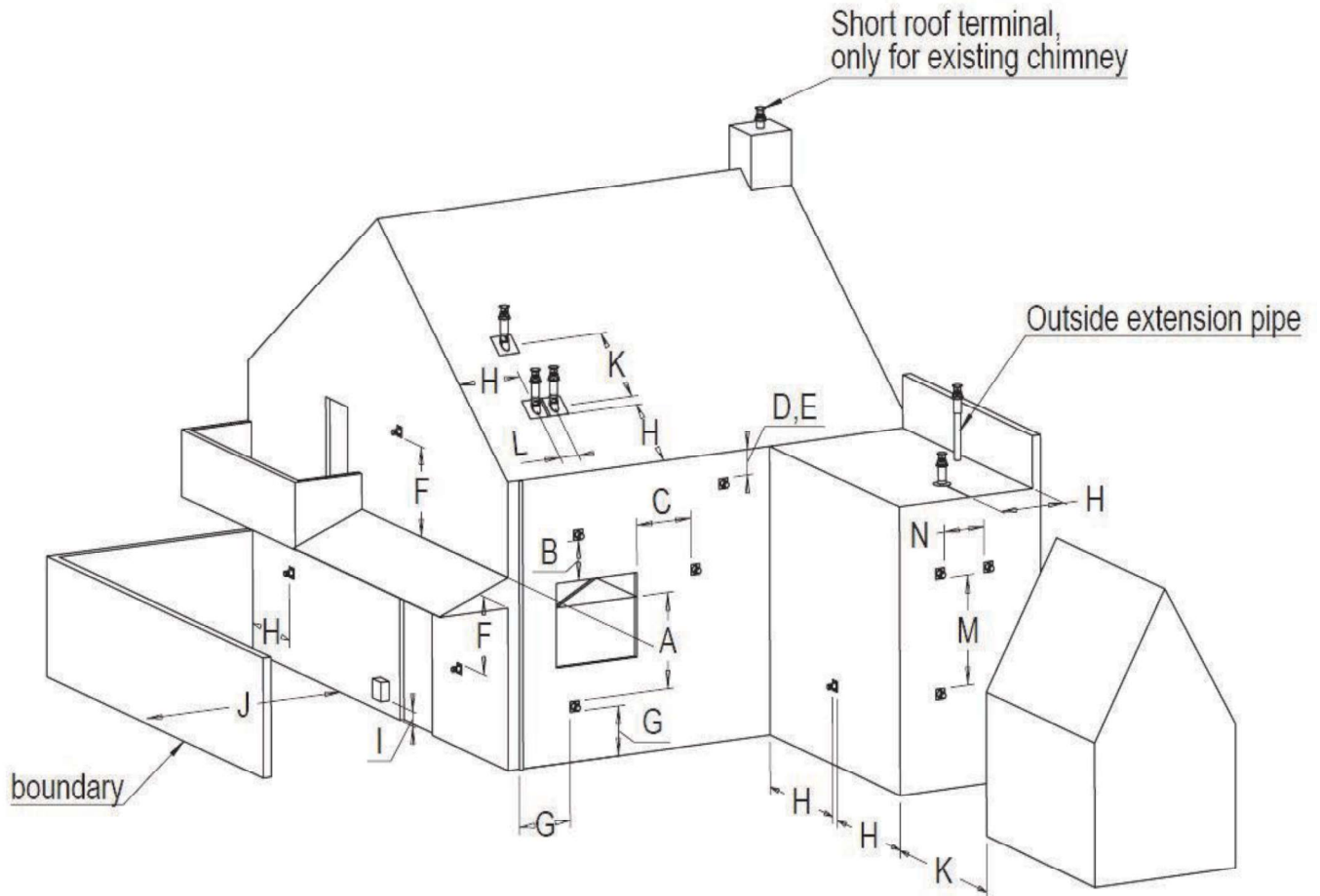

Dimensions	Terminal position	Distance mm
A	Distance to ventilation openings	Local*
B	Distance to ventilation openings	Local*
C	Distance to ventilation openings	Local*
D	Below a gutter soil pipes or drain pipes	500
E	Below eaves	500
F	Below carport, roof or balcony From Inner and outer corners	500
G	From a vertical soil pipes or drain pipes	300
H	Inside and outside of a corner	500
I	Above an outside gas pressure regulator	1000
	side of a gas pressure regulator	500
J	From a surface/boundary to a terminal	Local*
K	From a terminal facing a terminal	1000
L	From the centre of two roof terminals	450
M	Two Wall terminals above each other	1000
N	Two Wall terminals next each other	1000

***According local building regulations**

10. CLEANING AND MAINTENANCE

This appliance should be inspected and serviced once a year by a qualified, competent and registered person. The inspection and maintenance must at least ensure that the appliance is working correctly and safely. It is advisable to clean the appliance of any dust and debris before regularly during the heating season and especially if the appliance has not been used for some time. This can be done with a soft brush and a vacuum cleaner or a damp cloth and if required a non-abrasive cleaning agent. Do not use corrosive or abrasive substances to clean the appliance.

The Concentric flue system must be inspected and cleaned every 2 years.

Also control of:

- 1 Gas tightness of gas fire and concentric flue system.
- 2 The correct operation of the gas control and the ignition of the burner.

11.1 Anti Reflective glass; AR glass cleaning instructions. (see APPENDIX5)

General:

AR glass is a non-reflective ceramic glass. This glass is provided with a AR-coating on both sides of the glass. The anti-reflection coating gives a reduction in the reflection up to a minimal shine. The coating layers are more sensitive than the known ceramic glass, hence it is necessary to follow special cleaning procedures.

Important:

don't use any of the following cleaning materials:

Hard (abrasive) sponges, steel wool, abrasives and cleaners with ammonia or acid (citric acid as well)
Paper towels, ceramic cook top cleaner.

Only use: water or suitable detergents. We advise our Thermocet cleaner.

Procedure:

- * Wear soft cotton gloves at all times.
- * The rubber suction cup to take out the glass must be clean. (Scratch hazard).
- * Release the glass retaining strips and take the glass out of the appliance.
- * place the glass on a stable soft surface.
- * Use a soft (microfiber) cloth / soft sponge.
- * clean the glass with the special cleaner and or water.
- * Make sure there is no residue, such as fingerprints, left behind.
- * Replace the glass and tighten the glass retaining strips.
- * double check for residue on the outside of the glass, also left behind by the suction cup.

Important:

After the first use the inside of the pane will have a white haze, it is necessary to remove the white haze immediately after the first use, when the appliance has cooled.

The higher the frequency of use more frequent cleaning might be needed. Not timely cleaning of the glass can cause it to go dull and will be difficult to clean.

Information:

if an appliance with AR glass is placed near windows, or if there is a lot of light on the glass it is possible to detect reflection of colours. For example, a red sofa, white table or floor the stove can cause the glass to reflect these colours.

As the glass is cleaned more often or with not accepted products it will lose some of the AR effect.

11. TROUBLESHOOTING LIST MERTIK GV60

No	ACTION		Possible problem/cause	Solution
1.	Option: wall switch START: press ON button > wall switch works.	NO →	Bent pin on switch, or cable not operating properly.	Straighten pin, replace wall switch or cable.
1.	Manual transmitter START: press both buttons to start ignition sequence. Beep will occur each second	NO →	Manual transmitter battery low.	Replace battery, 2x AAA 1.5V quality alkaline!
			Receiver batteries low.	Replace batteries, 2x AA 1.5V quality alkaline!
			Optional mains adapter not operating properly.	Check mains adapter.
			Check coding of transmitter and receiver.	Learn in new code, see instructions and label on receiver.
			Transmitter/receiver range limited.	1. Move antenna cable, see instructions. 2. Replace receiver.
			Optional wall switch / cabling not operating properly.	Replace wall switch / cabling.
			Receiver fuse blown (in older versions only).	Replace receiver.
		OK ↓		
2.	Magnet unit in gas valve is energised (audible click)	NO →	No beep	Impulse magnet not operating properly. Replace gas valve.
		NO →	3 short beeps	Receiver batteries low. Replace batteries, 4x 1.5V AA quality alkaline!
		NO →	1 long beep	ON/OFF switch on gas valve in OFF position Set switch to ON.
			8-wire cable between receiver and gas valve defective / poor contact.	Check cable, especially in case of plug connection.
			Switch cable disconnected.	Check switch cable, see fig. 1 on page 18
			Motor not operating properly.	Replace gas valve.
			Micro switch on gas valve not operating properly.	Replace gas valve.
		OK ↓		

No	ACTION	Possible problem/cause	Solution
----	--------	------------------------	----------

3.	<div style="border: 1px solid black; padding: 5px; width: 150px; height: 100px; display: flex; flex-direction: column; justify-content: space-around;"> <div>Continuous spark</div> <div>Spark will occur each second.</div> </div>	NO →	Ignition components not operating properly.	<div style="border: 1px solid black; padding: 2px;">Check connection between cable & IGN electrode.</div> <div style="border: 1px solid black; padding: 2px;">Check IGN electrode spark gap.</div> <div style="border: 1px solid black; padding: 2px;">Check IGN electrode for discharge to ground (break in ceramic).</div> <div style="border: 1px solid black; padding: 2px;">Check IGN cable for damage</div> <div style="border: 1px solid black; padding: 2px;">Increase distance between IGN cable and all metal parts. Check that spark does not discharge to ground at location of spark plug connection. Shorten cable if possible. If applicable, provide extra insulation with silicon hose etc.</div>
		NO →	IGN sequence stops, no pilot flame. No reaction to transmitter command (receiver does not react).	<div style="border: 1px solid black; padding: 2px;">Press RESET button, see instructions.</div> <div style="border: 1px solid black; padding: 2px;">Add ground wire between pilot burner and gas valve.</div> <div style="border: 1px solid black; padding: 2px;">Do not coil the IGN cable.</div> <div style="border: 1px solid black; padding: 2px;">Shorten IGN cable if possible.</div>
		NO →	IGN sequence stops, no pilot flame. Transmitter command is possible.	IGN sequence stops, no pilot flame. Transmitter command is possible.

OK
↓

4.	<div style="border: 1px solid black; padding: 5px; width: 150px; height: 30px;">Pilot lit.</div>	NO →	TC and SW cable reversed.	Check connection of cable to receiver and interrupter, see fig. 1.
			Impulse magnet not operating properly.	Replace gas valve.
			Short between interrupter and SW cable.	Check connection to interrupter.
			No gas magnet unit drops after 30 second audible count).	Check gas supply to gas valve.

OK
↓

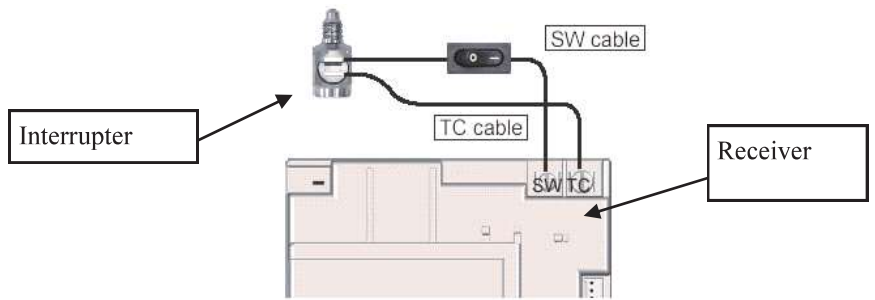

Figure 1

5.	<div style="border: 1px solid black; padding: 5px; width: 150px; height: 30px;">Sparkling stops after pilot is lit</div>	NO →	Short between interrupter and TC cable.	Check connection to interrupter, see fig. 1
			Electronic measuring amplifier defective.	Replace receiver.

OK
↓

No ACTION	Possible problem/cause	Solution
-----------	------------------------	----------

<p>6.</p> <div style="border: 1px solid black; height: 200px; width: 100%; display: flex; align-items: center; justify-content: center; text-align: center;"> <p>Motor turns to main gas and pilot stays lit.</p> </div>	<p>NO →</p> <p>Magnet unit drops (audible click)</p>	<table border="1" style="width: 100%; border-collapse: collapse;"> <tbody> <tr> <td style="padding: 5px;">Resistance in thermo current circuit too high.</td> <td style="padding: 5px;">Check cables and connections in thermo current circuit.</td> </tr> <tr> <td style="padding: 5px;">Not enough heat on thermocouple.</td> <td style="padding: 5px;">Check position of pilot to thermocouple and intensity of pilot flame.</td> </tr> <tr> <td style="padding: 5px;">Low voltage from thermocouple.</td> <td style="padding: 5px;">Check connections and, if necessary, replace thermocouple. Do not over tighten the connections!</td> </tr> <tr> <td style="padding: 5px;">Short because thermocouple end is damaged.</td> <td style="padding: 5px;">Replace thermocouple, do not overtighten the connections!</td> </tr> </tbody> </table>	Resistance in thermo current circuit too high.	Check cables and connections in thermo current circuit.	Not enough heat on thermocouple.	Check position of pilot to thermocouple and intensity of pilot flame.	Low voltage from thermocouple.	Check connections and, if necessary, replace thermocouple. Do not over tighten the connections!	Short because thermocouple end is damaged.	Replace thermocouple, do not overtighten the connections!
Resistance in thermo current circuit too high.	Check cables and connections in thermo current circuit.									
Not enough heat on thermocouple.	Check position of pilot to thermocouple and intensity of pilot flame.									
Low voltage from thermocouple.	Check connections and, if necessary, replace thermocouple. Do not over tighten the connections!									
Short because thermocouple end is damaged.	Replace thermocouple, do not overtighten the connections!									
<p>OK</p> <p>↓</p>	<p>NO →</p>	<table border="1" style="width: 100%; border-collapse: collapse;"> <tbody> <tr> <td style="padding: 5px;">IGN sequence stops. No reaction to transmitter command (receiver does not react).</td> <td style="padding: 5px;">Press RESET button, see instructions.</td> </tr> <tr> <td style="padding: 5px;"></td> <td style="padding: 5px;">Add ground wire between pilot burner and gas valve.</td> </tr> <tr> <td style="padding: 5px;"></td> <td style="padding: 5px;">Do not coil the IGN cable.</td> </tr> <tr> <td style="padding: 5px;"></td> <td style="padding: 5px;">Shorten IGN cable if possible.</td> </tr> </tbody> </table>	IGN sequence stops. No reaction to transmitter command (receiver does not react).	Press RESET button, see instructions.		Add ground wire between pilot burner and gas valve.		Do not coil the IGN cable.		Shorten IGN cable if possible.
IGN sequence stops. No reaction to transmitter command (receiver does not react).	Press RESET button, see instructions.									
	Add ground wire between pilot burner and gas valve.									
	Do not coil the IGN cable.									
	Shorten IGN cable if possible.									
<p>7.</p> <div style="border: 1px solid black; padding: 5px; width: 100%;"> <p>Main burner is lit.</p> </div>	<p>NO →</p>	<table border="1" style="width: 100%; border-collapse: collapse;"> <tbody> <tr> <td style="padding: 5px;">Gas valve manual knob in "MAN" position.</td> <td style="padding: 5px;">Turn knob to "ON" position.</td> </tr> </tbody> </table>	Gas valve manual knob in "MAN" position.	Turn knob to "ON" position.						
Gas valve manual knob in "MAN" position.	Turn knob to "ON" position.									
<p>OK</p> <p>↓</p>	<p>NO →</p>	<table border="1" style="width: 100%; border-collapse: collapse;"> <tbody> <tr> <td style="padding: 5px;">Too much / too little air flow / draft at pilot, blows out or is smothered.</td> <td style="padding: 5px;">Check whether restriction plate has been correctly applied in unit, see instructions. Poor flue location, check correctness of layout and connections.</td> </tr> </tbody> </table>	Too much / too little air flow / draft at pilot, blows out or is smothered.	Check whether restriction plate has been correctly applied in unit, see instructions. Poor flue location, check correctness of layout and connections.						
Too much / too little air flow / draft at pilot, blows out or is smothered.	Check whether restriction plate has been correctly applied in unit, see instructions. Poor flue location, check correctness of layout and connections.									
<p>8.</p> <div style="border: 1px solid black; padding: 5px; width: 100%;"> <p>Main burner stays lit.</p> </div>	<p>NO →</p>	<table border="1" style="width: 100%; border-collapse: collapse;"> <tbody> <tr> <td style="padding: 5px;">Receiver batteries low.</td> <td style="padding: 5px;">Replace batteries, 1.5V AA quality alkaline!</td> </tr> </tbody> </table>	Receiver batteries low.	Replace batteries, 1.5V AA quality alkaline!						
Receiver batteries low.	Replace batteries, 1.5V AA quality alkaline!									
<p>OK</p> <p>↓</p>	<p>NO →</p>	<table border="1" style="width: 100%; border-collapse: collapse;"> <tbody> <tr> <td style="padding: 5px;">Receiver batteries low.</td> <td style="padding: 5px;">Replace batteries, 1.5V AA quality alkaline!</td> </tr> </tbody> </table>	Receiver batteries low.	Replace batteries, 1.5V AA quality alkaline!						
Receiver batteries low.	Replace batteries, 1.5V AA quality alkaline!									
<p>9.</p> <div style="border: 1px solid black; padding: 5px; width: 100%;"> <p>Magnet unit drops while motor turns. 3 beeps</p> </div>	<p>NO →</p>	<table border="1" style="width: 100%; border-collapse: collapse;"> <tbody> <tr> <td style="padding: 5px;">Receiver batteries low.</td> <td style="padding: 5px;">Replace batteries, 1.5V AA quality alkaline!</td> </tr> </tbody> </table>	Receiver batteries low.	Replace batteries, 1.5V AA quality alkaline!						
Receiver batteries low.	Replace batteries, 1.5V AA quality alkaline!									

