

OPERATING AND INSTALLATION INSTRUCTIONS

SCAN-LINE 550 INSET STOVE



www.heta.dk



EN

DANISH DESIGN . DANISH QUALITY . DANISH PRODUCTION

Congratulations on your new stove. We are sure that you will be happy with your investment, especially if you follow the advice and instructions we have put together in these operating instructions. The Scan-Line 550 inset stove has been approved according to the EN 13229, DIN+, and 15a B-VG. Approval means that consumers can be sure, that the stove meets a range of specifications and requirements intended to ensure that the materials used are of good quality, that the stove does not adversely affect the environment, and that it is economical to use.

With your new stove you should have received the following:

- a. Operating instructions
- b. Guarantee slip
- c. A stove glove

INSTALLATION INSTRUCTIONS

Safety clearances

Stoves must always be installed in line with national and, if applicable, local regulations. It is important to abide by local regulations regarding setting up chimneys and connection to same. Therefore, always consult your local chimney sweep before installation, as you are personally responsible for ensuring that the applicable regulations have been met.

Distance regulations

A difference applies to installation next to flammable and non-flammable walls.

Warning



A stove gets hot. (In excess of 90 degrees) Take care to ensure that children cannot come into contact with it.

IMPORTANT

1. Make sure there is adequate provision to sweep the chimney.
2. Make sure there is adequate ventilation to the room.
3. Please note that any extraction fans operating in the same room as the wood-burning stove can reduce the chimney draft – which may have an adverse effect on stove combustion properties. In addition, this may cause smoke to be emitted from the stove when the firing door is opened.
4. It must not be possible to cover any air vents.

The floor

A non-flammable floor surface (e.g. steel, tile, brick), must extend from the front of the fireplace for a minimum of 30 cm.

The chimney connection

The chimney opening must follow national and local regulations. However, the area of the opening should never be less than 175 cm², which corresponds to a diameter of 150 mm. If a damper is fitted in the flue gas pipe, there must always be at least 20 cm² of free passage, even when the damper is in its “closed” position. If local regulations permit, two contained fireplaces can be connected to the same chimney. However, you must abide by local regulations regarding the distance between the two connections. **The stove must never be connected to chimneys that are also linked to a gasfired heater.** An efficient stove makes high demand on chimney properties – so always have your local chimney sweep evaluate your chimney.

Connection to a brick chimney

Brick a thimble into the chimney and seat the flue gas pipe in this. The thimble and flue gas pipe must not penetrate the chimney opening itself, but must be flush with the inside of the chimney duct. Joins between brickwork, the thimble and flue gas pipe must be sealed with fireproof material and/or beading.

Connection to a steel chimney

When fitting a connection from a top-output stove directly to a steel chimney, we recommend fitting the chimney tube inside the flue gas spigot so that any soot and condensation drops into the stove itself rather than collecting on the exterior surface of the stove.

For connections to chimneys that are run through ceilings, all national and local regulations regarding distance to flammable material must be followed. It is important that the chimney is fitted

with roof support so that the top panel of the stove is not required to bear the entire weight of the chimney (excessive weight may damage the stove).

Draft conditions

Poor draft may result in smoke being emitted from the stove when the door is opened. The minimum chimney draft to ensure satisfactory combustion in stoves of this kind is 12 PA. However, there will still be a risk of smoke emission if the firing door is opened during powerful firing. The flue gas temperature at nominal output is 290°C when expelled to an exterior temperature of 20°C. The flue gas mass flow is 6 g/sec. The chimney draft is generated by the difference between the high temperature of the chimney and the low temperature of the fresh air. The length and insulation of the chimney, wind and weather conditions also have an effect on the ability of the chimney to generate appropriate under-pressure.

If the stove has not been used in a while, check that the chimney and stove are not blocked with soot, bird nests, etc., before using it.

Reduced draft can occur when:

- The difference in temperature is too small – due to insufficient chimney insulation, for example.
- The outdoor temperature is too high – in summer, for example.
- No wind is blowing.
- The chimney is too low and sheltered.
- The chimney contains false air.
- The chimney and flue gas pipe are blocked.

- The house is too airtight (i.e. when there is an insufficient supply of fresh air).
- Poor smoke extraction (poor draft conditions) due to a cold chimney or bad weather conditions can be compensated for by increasing the airflow into the stove.

Good draft occurs when:

- The difference in temperature between the chimney and outdoor air is high.
- The weather is fine.
- The wind is blowing strongly.
- The chimney is of the correct height: at least 4.00 m above the stove and free of the roof ridge.

Combustion air flow

The insert stove is approved as a room air-dependent insert stove in accordance with EN 13229. All the combustion air flow in the inset stove comes from the room in which it is fitted. However, by connecting a sealed air inlet to the insert stove's air intake connectors, the stove can be supplied with external combustion air flow. In this respect, the following requirements must be met:

- Only approved materials may be used from the ventilation unit to the air inlet vent.
- The air inlet vent must be fitted correctly and insulated to prevent formation of condensate. The cross section of the vent and grille must be at least 78 cm².
- If the vent leads out into the open air, please note that the grille must be fitted with suitable wind protection. There must be no risk that the grille can get clogged by leaves, etc.

SPARE PARTS FOR ASSEMBLING

Enclosed

Flue collar

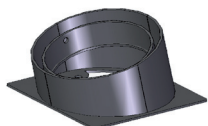

2 magnet fittings



To be ordered separately

Collar for external air inlet

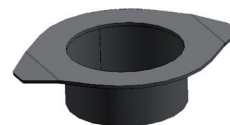

2 springs

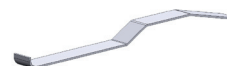

Flange



Sealing cord



Assembling the convection box

1. The flue collar is always put in the combustion chamber. The flue collar is fitted on the chimney pipe where the inset stove later will be installed. This is done to ease the connection at the end.
2. Assemble the convection box. It has to be adjusted exactly to horizontal level by means of the adjustable bolts at the bottom (this should be done before the inset stove is put in).
3. Before the convection box is installed you have to make up your mind if the inset stove should pass on heat to some stone mass (thermal mass stove effect). Should you want this effect the flange above the convection box should not be fitted. On the other hand should you want direct convection heat through the distance between the convection box and inset stove the flange has to be fitted, so that the heat does not disappear into the stone mass.

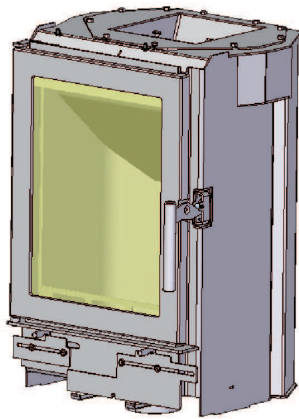

Inset stove

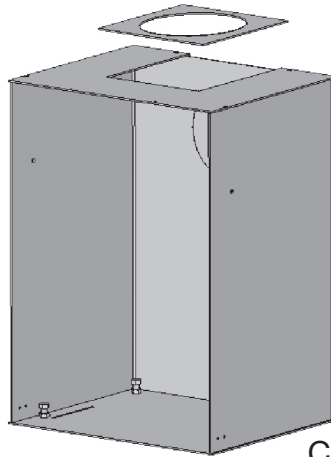

Convection box



Chimney

Flue collar

Installing the inset stove into the convection box

1. Remove the magnet fittings from the convection box to ease the installation.
2. Remove the vermiculite bricks from the combustion chamber.
3. Lift the stove and put it into the convection box.
4. The stove has to fall into place in the grooves at the bottom of the convection box so that the distance to the sides of convection box is equal.
5. Adjust the stove back and forward in the grooves so that the door is in line with the front frame, which will be fitted at the end.
6. When the stove is fitted correctly it has to be fastened with the screws at the back of the combustion chamber. The top screw has to go through both the combustion chamber and the convection box. The bottom screw has to be screwed against the convection box as back pressure.
7. Insert the vermiculite bricks in the combustion chamber again.
8. Fit both magnet fittings again. It is important that they are in level, so that the magnet can get a proper grip.
9. To fit the front frame the door must be fully open. Loosen the two screws which the frame should be hung upon and hook the frame on. Adjust the frame so that it is in line with the stove and fasten the screws again.

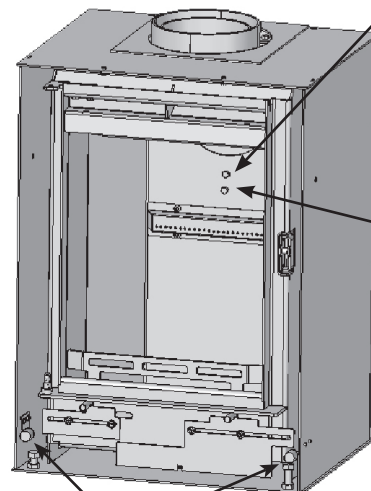

The top screw has to go through both the combustion chamber and the convection box.

The bottom screw has to be screwed against the convection box as back pressure.

Magnet fittings

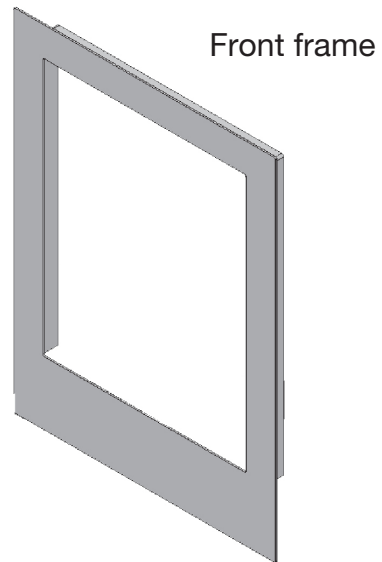
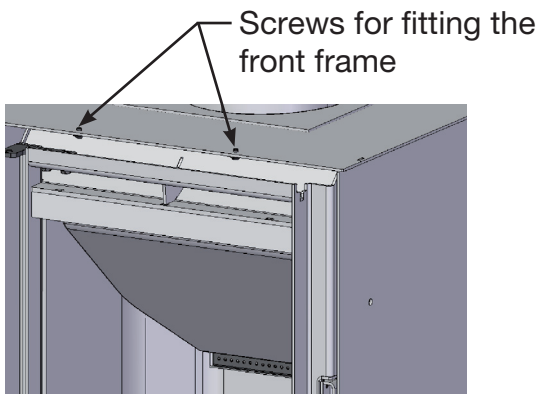

Fitting the collar for external air inlet

1. Remove/hit the cut out ring at the bottom of the convection box.
2. Place the collar for external air inlet at the bottom of the convection box as shown on the picture.
3. Glue the sealing cord underneath the air box as shown.
4. Install the stove into the convection box as previously described and press the external air inlet collar against the bottom of the stove by using the enclosed 2 springs, which should be left there to keep the collar in place.
5. With advantage remove the air damper for the secondary airflow while the springs are fitted.

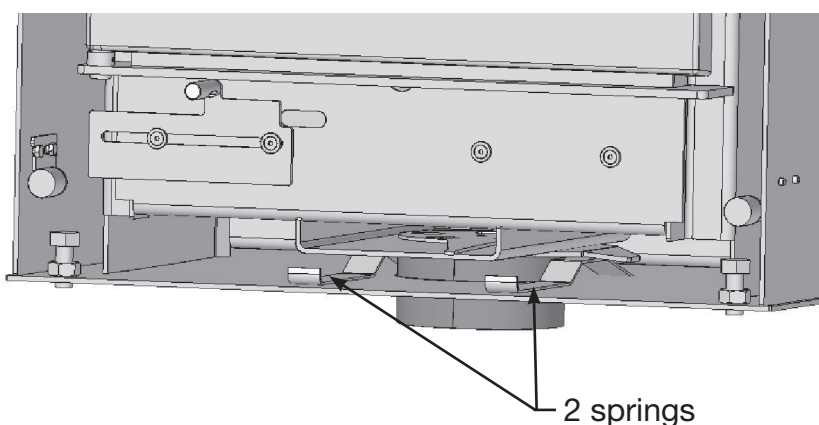
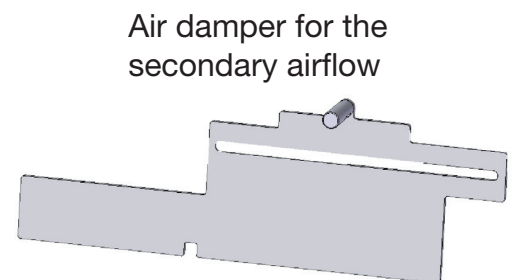
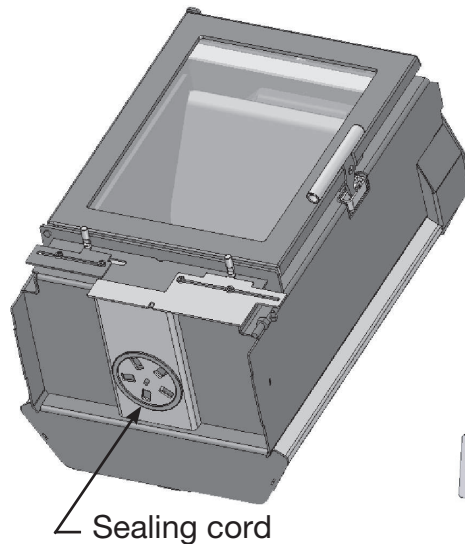
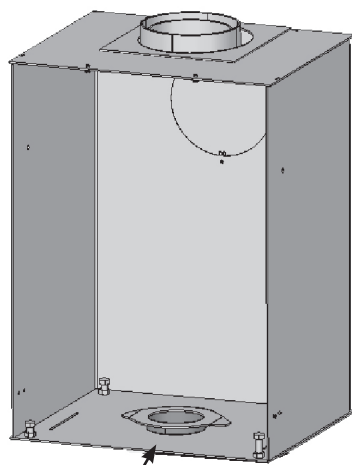

INSTRUCTIONS FOR USE

First firing

The stove paint is fully cured from the factory, but a minor unpleasant odour could still arise.

Fuel

Your new stove is EN approved for firing with wood fuel. You must therefore only burn clean, dry wood in your stove. Never use your stove to burn driftwood, as this may contain a lot of salt which can damage both the stove and the chimney. Similarly, you must not fire your stove with refuse, painted wood, pressure-impregnated wood or chipboard, as these materials can emit poisonous fumes and smoke. Correct firing using well seasoned wood provides optimal heat output and maximum economy. At the same time, correct firing prevents environmental damage in the form of smoke and emissions and also reduces the risk of chimney fires. If the wood is wet and inadequately seasoned, a large proportion of the energy in the fuel will be used to vaporise the water, and this will all disappear up the chimney. Thus it is important to use dry, well seasoned wood, i.e. wood with a moisture content of no more than 20%. This is achieved by storing the wood for 1–2 years before use. Pieces of firewood with a diameter of more than 10 cm should be split before storing. The pieces of firewood should be of an appropriate length (approx. 25 cm) so that they can lie flat on the bed of embers. If you store your wood outdoors, it is best to cover it.

Examples of fuel values

for different woods and their typical densities per cubic meter, specified for 100% wood with a moisture content of 18%.

Wood	kg/m ³	Wood	kg/m ³
Beech	710	Willow	560
Oak	700	Alder	540
Ash	700	Scotch pine	520
Elm	690	Larch	520
Maple	660	Lime	510
Birch	620	Spruce	450
Mountain pine	600	Poplar	450

It is advised not to use very oil-containing woods like teak tree and mahogany, as this can cause damage to the glass.

Heating value in wood

You have to use about 2.4 kg normal wood to replace one litre of heating oil. All woods have almost the same heating value per kg, which is about 5.27 kW/hour for absolute dry wood. Wood with a moistness of 18% has a efficiency of about 4.18 kW/hour per kg, and one litre heating oil contains about 10 kW/hour.

CO₂ release

At combustion 1000 litres of heating oil forms 3.171 tons CO₂. As wood is a CO₂ neutral heat/energy source, you save the environment about 1.3 kg CO₂ every time you have used 1 kg normal wood.

Chimney fires

In the event of a chimney fire – which often results from incorrect operation or protracted firing with moist wood – close the door and shut off the secondary/start-up air supply to smother the fire. Call the fire department.

Regulating the airflow

Secondary airflow is regulated using the operating handle below the glass door. The secondary airflow is fully open when the operating handle is in the right position, and fully closed when positioned to the left.

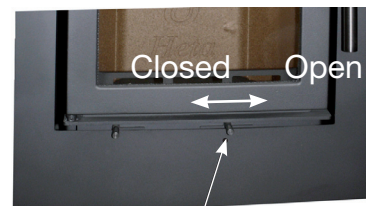

Fig. 1

Secondary airflow

Start-up airflow

To open the start-up airflow for the stove, pull the handle on the start-up mechanism as far to the left-hand side of the stove (as seen from the front) as possible. See fig. 2. To close the start-

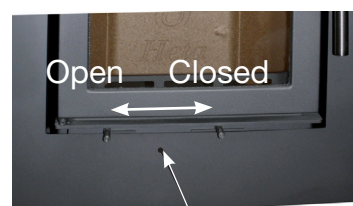

Fig. 2

Start-up mechanism

up airflow for the stove, push the handle on the start-up mechanism as far to the right-hand side of the stove (as seen from the front) as possible.

Lighting the stove

Place two pieces of wood on the bottom. Stack kindling on top in layers with air between. Setting fire starter (bag, brick, paraffin) on the top, now you are ready to light the fuel. The flames must work from the top down.



The use of lighter fluid, oils or any liquid fuels is strictly forbidden from use in a wood stove.

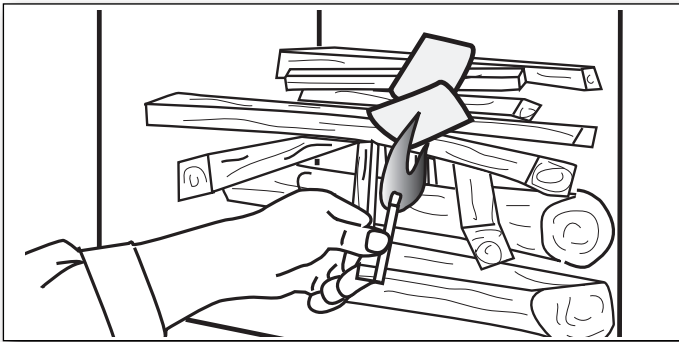

Fully open the combustion air and leave the door ajar (about 1 cm open).

Once the fire is established and the chimney is hot (after about 3-5 minutes) closed door and regulate the air into operating position. We recommend, all of the first fuel is burned with the combustion air fully open in the operating position. This ensures the stove and chimney are thoroughly heated.



Startup/Lighting
Scan the code and select a language.

Refiring

You should normally refire the stove while there is still a good layer of embers. Distribute the embers across the bottom grate, place pieces of fuel (max. 2,5 kg) on the embers in a single layer perpendicular to the firing opening. Close the firing door. The wood will then ignite within 30 to 60 seconds. When the flames are steady, adjust the secondary airflow to the level required. Nominal operation (5 kW) will be achieved when the secondary airflow is fully open. When firing, take care not to place the pieces of fuel too closely together, as this will result in poor combustion and insufficient exploitation of the fuel.

Please note that the start-up mechanism must not remain open during normal operation of the

stove, as *this may lead to overheating. It must only be used until the fuel is burning with a steady flame.*

Reduced burning

The stove is well-suited to intermittent use. If you wish to operate the stove with reduced out-put, simply insert smaller volumes of wood at each firing, and apply a lower airflow. However, remember that the secondary combustion air supply must never be shut off completely during firing. It is important to keep a good bed of embers. Gentle heat is released when the fire settles - i.e. when the wood no longer generates flames and has been converted to glowing embers.

Optimal firing

To achieve optimal firing and the highest possible effect, it is important to make sure that the air supply is used correctly. As a general rule, the secondary air is to be used to control the fire to ignite the flue gases. This produces a high effect and keeps the glass panel completely clear of soot as the secondary air “washes” down over it. Please note that the stove will, naturally, produce soot if the secondary air intakes are closed completely. This will prevent oxygen from being drawn into the stove, and the viewing window and other parts will become covered with soot. If this situation is combined with firing with wet wood, the build-up of soot can become so thick and sticky that the sealing rope can, for example, become detached when the door is opened the next day.

Risk of explosion



After you add new fuel, it is very important that you do not leave the stove unattended until the wood is burning constantly. This will normally occur within 30 to 60 seconds.

A risk of explosion can possibly arise if too much wood is placed in the stove. This may result in the production of large volumes of gas, and this gas can explode if the intake of primary and secondary air is insufficient.

It is an advantage always to leave some ash lying in the bottom of the combustion chamber.

Be careful when emptying the ashes. Hot embers can remain in the ash for a long time.

Stove data table in accordance with EN 13229 testing.

Stove type Scan-Line inset stove	Nominal fluegas temperature C°	Smoke stub mm	Fuel volume kg	Draught min mbar	Nominal output tested kW	Heat output %	Distance to flammable materials at the sides mm	Distance to furnitures from the stove mm	Stove weight kg
550	231	ø150	1,4	0,12	5	81	500	800	96

The nominal output is the output to which the stove has been tested.

The test was carried out with the secondary air 100% open.

Operational problems

The chimney must be swept at least once a year, we recommend the use of a NACS (national association of chimney sweeps) registered chimney sweep. In the event of smoke or malodorous fumes being produced, you must first check to see whether the chimney is blocked. The chimney must, of course, always provide the minimum draught necessary to ensure that it is possible to regulate the fire. Please note, however, that chimney draft is dependent on the weather conditions. In high winds, the draft can become so powerful that it may be necessary to fit a damper in the flue gas pipe to regulate the

draft. When cleaning the chimney, soot and other deposits may come to fall on the smoke plate. In cases where the wood burns too quickly, this may be due to excessive chimney draught. You should also check to make sure that the door seal and ashpan seal is intact and correctly fitting.

If the stove is generating too little heat, this may be because you are firing with wet wood. In this case, much of the heating energy is used to dry the wood, resulting in poor heating economics and an increased risk of soot deposits in the chimney.

MAINTENANCE

The surface of the stove has been treated with heat-resistant paint.

The stove should be cleaned with a damp cloth. Any damage to the surface in the form of chips or scratches can be repaired using touch-up paint, which is available in spray cans.

Cleaning the glass

Incorrect firing, for example using wet wood, can result in the viewing window becoming covered in soot. This soot can be easily and effectively removed by using proprietary stove glass cleaner.

Cleaning after sweeping the chimney and replacing the stones.

Fig 1-2

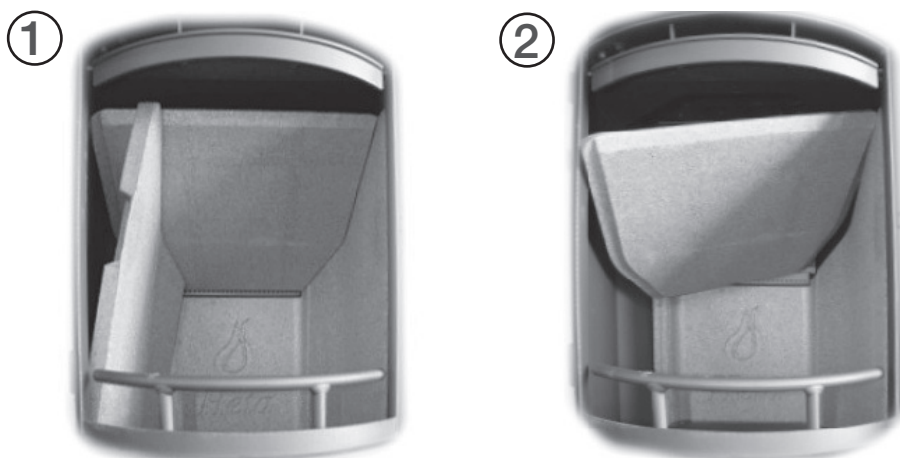

Safety distances Scan-Line 550 Insert stove:

Materials such as fermacell gypsum fibreboard, isolath 1000, mineral wool fire batts and aerated concrete can also be used around the stove.

When using materials other than fermacell gypsum fibreboard, ensure these have the same insulation properties as 12,5 fermacell.

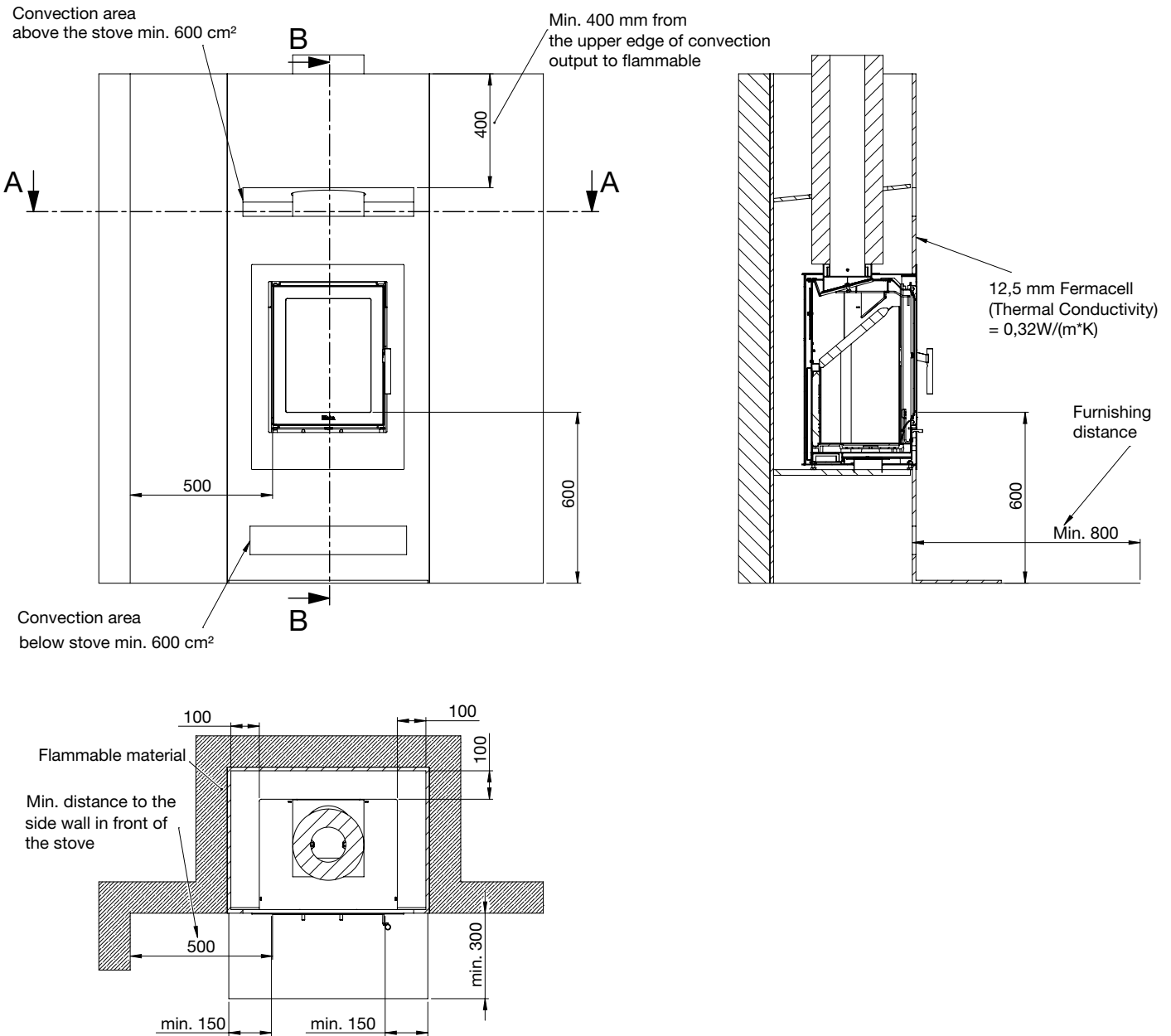

GUARANTEE

Heta inset stoves are subjected to stringent quality control procedures both throughout the production process and immediately before delivery to the dealer. Therefore, the stoves are guaranteed against defects in manufacturing

For five years.

This guarantee does not cover: Wearing parts/fragile parts such as:

- The fire-proof bricks in the combustion chamber.
- The smoke baffle
- The glass
- The sealing rope
- The grate frame.

Damage resulting from incorrect use Transport costs in connection with repairs carried out under guarantee Installation/disassembly in connection with repairs carried out under guarantee.

Should you have cause to make a complaint, please quote our invoice no.

Warning



Any unauthorised modification of the stove and any use of non-original spares will void the guarantee.

