



SEALED PELLET STOVE

MAY AIR 7 S1

MAY AIR 7 UP! S1

Translation of original instructions

MCZ

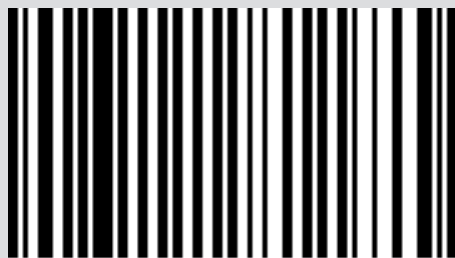

8902020901

TABLE OF CONTENTS

| | |
|--|-----------|
| TABLE OF CONTENTS | II |
| INTRODUCTION | 1 |
| 1-WARNINGS AND WARRANTY CONDITIONS | 2 |
| 2-INSTALLATION | 9 |
| 3-DRAWINGS AND TECHNICAL SPECIFICATIONS | 18 |
| 5- SMOKE OUTLET | 23 |
| 6-INSTALLATION AND ASSEMBLY | 29 |
| 7-OPENING THE DOORS | 38 |
| 8-CONNECTION TO ADDITIONAL DEVICES | 39 |
| 9-LOADING THE PELLETS | 40 |
| 10-ELECTRICAL CONNECTION | 41 |
| 11-FIRST START-UP | 42 |
| 12-CONTROL PANEL | 44 |
| 13-MENU ENTRIES AND OPERATION | 45 |
| 14-SAFETY DEVICES | 53 |
| 15-ALARMS | 54 |
| 16-RECOMMENDATIONS FOR SAFE USE | 59 |
| 17-CLEANING | 60 |
| 18-FAULTS/CAUSES/SOLUTIONS | 67 |
| 19-CIRCUIT BOARD | 69 |

INTRODUCTION

Dear Customer,

Our products are designed and manufactured in accordance with standards in force, with high quality materials and using our extensive experience in the transformation processes.

To get the best performance, we suggest you read the instructions in this manual carefully.

This installation guide is an integral part of the product: ensure that the manual is always supplied with the appliance, even if it changes owner. If the manual is lost, you can request another copy from the local Technical Dept. or download it directly from the company's website.

All local regulations, including those referring to national and European standards, must be observed when installing the appliance.

In Italy, for the installation of systems with a biomass below 35KW, refer to the Ministerial Decree 37/08 and the qualified installation technician with the suitable requirements must issue a certificate of compliance for the system installed. (By system we intend Stove+Flue+Air inlet).

REVISIONS TO THE PUBLICATION

The content of this manual is strictly technical and the property of MCZ Group Spa.





No part of this manual may be translated into other languages, adapted and/or reproduced, even in part, in other mechanical and/or electronic form or media, for photocopies, recordings or other, without the prior written authorisation of MCZ Group Spa.

The company reserves the right to make changes to the product at any time without prior notice. The owner company reserves its rights according to law.

CARE OF THE MANUAL AND HOW TO CONSULT IT

- Take care of this manual and store it in an easily and quickly accessible place.
- Should this manual be lost or destroyed, request a copy from your retailer or directly from the authorised Technical assistance department. It can also be downloaded from the company's website.
- "**Bold text**" requires special attention.
- "*Text in italics*" is used to draw attention to other paragraphs in the manual or for any additional clarifications.
- "Note" provides the reader with additional information.

SYMBOLS USED IN THE MANUAL

| | |
|---|--|
|  | ATTENTION: carefully read the relative message as failure to comply with the information provided may result in serious damage to the product and danger to the persons who use it. |
|  | INFORMATION: failure to comply with these provisions will compromise use of the product. |
|  | OPERATING SEQUENCES: sequence of buttons to be pressed to access the menus or perform adjustments. |
|  | MANUAL carefully read this manual or the relative instructions. |

SAFETY PRECAUTIONS

- **Installation, electrical connection, operating check and maintenance must only be carried out by authorised and qualified personnel.**
- **Install the product in accordance with all local and national legislation and regulations in force in the region or state.**
- Only use the fuel recommended by the manufacturer. The product must not be used as an incinerator.
- It is strictly forbidden to use alcohol, petrol, liquid fuel for lanterns, diesel, bio-ethanol, fluids for lighting charcoal or similar liquids to light/rekindle the flame in these devices. Keep these flammable liquids well away from the appliance when in use.
- Do not put any fuel other than wood pellets in the hopper.
- The instructions provided in this manual must always be complied with to ensure the product and any electronic appliances connected to it are used correctly and to prevent accidents.
- **This appliance can be used by children aged 8 years and above and persons with reduced physical, sensory or mental capabilities or lack of experience and knowledge provided they are supervised or have been given instructions regarding use of the appliance in a safe way and understand the hazards involved. Children must not play with the appliance. Cleaning and maintenance to be performed by the user must not be carried out by children without supervision.**
- The user, or whoever is operating the product, must read and fully understand the contents of this installation guide before performing any operation. Errors or incorrect settings may cause hazardous conditions and/or incorrect operation.
- Do not climb on or lean on the product.

1-WARNINGS AND WARRANTY CONDITIONS

- Do not dry laundry on the product. Any drying racks or the like must be kept at a safe distance from the product. **Fire hazard.**
- *All liability for improper use of the product is entirely borne by the user and relieves the manufacturer of any civil and criminal liability.*
- Any type of tampering or unauthorised replacement with non-original spare parts may be hazardous for the operator's safety and relieves the company of any civil and criminal liability.
- Many surfaces of the product get very hot (door, handle, glass, smoke outlet pipes, etc.). **Avoid coming into contact with these parts without adequate protective clothing or suitable equipment, such as gloves with thermal protection** or "cold handle" operating systems.
- **It is forbidden to operate the product with the door open or the glass broken.**
- **The doors/covers on the appliance must remain closed when it is not being used.**
- The product must be powered by an electrical system that is equipped with an effective earthing device.
- Switch the product off in the event of a fault or malfunction.
- Accumulated unburnt pellets in the burner after each "failed ignition" must be removed before lighting again. Check that the burner is clean and positioned properly before lighting again.
- Do not wash the product with water. Water may penetrate inside the unit and damage the electrical insulation and cause electric shocks.
- Do not stand for a long time in front of the product in operation. Do not overheat the room you are in and where the product is installed. This may harm one's physical conditions and cause health problems.
- Install the product in rooms that do not pose a fire hazard and are equipped with power and air supplies and smoke outlets.
- In the event of fire in the chimney, turn off the device, disconnect it from the mains and do not open the door whatsoever. Then contact the competent authorities.
- The product and the cladding must be stored in a dry place and must not be

1-WARNINGS AND WARRANTY CONDITIONS

exposed to weathering.

- It is recommended not to remove the feet that support the product in order to ensure adequate insulation, especially if the flooring is made of flammable materials.
- In the event of a malfunction of the ignition system, do not force it on by using flammable materials.
- Special maintenance must only be performed by authorised and qualified personnel.
- Assess the static conditions of the surface on which the weight of the product will rest and provide suitable insulation if it is made of flammable material (e.g. wood, fitted carpet or plastic).
- Live electrical parts: only power the product once it has been fully assembled.
- Disconnect the product from the 230V power supply before performing any maintenance operations.
- Improper use or poor maintenance of the product can cause hazardous situations to arise.
- **It is forbidden to manually load the fuel into the brazier. Failure to follow this warning can lead to hazardous situations.**
- **Before the product is restarted, always remove any unburned pellets building up in the brazier due to failed ignition, the emptying of the hopper or any situation that may cause this condition.**

1-WARNINGS AND WARRANTY CONDITIONS

INFORMATION:

Please contact the retailer or qualified personnel authorised by the company to resolve a problem.

- Only use the fuel specified by the manufacturer.
- When the product is switched on for the first time, it is normal for it to emit smoke due to the paint heating up for the first time. Therefore make sure the room it is installed in is well-ventilated.
- Check and clean the smoke outlet pipes regularly (chimney fitting).
- The product is not a cooking appliance.
- Always keep the cover of the fuel hopper closed.
- Store this installation and user manual with care as it must accompany the product for the duration of its useful life. If the product is sold or transferred to another user, always ensure the manual is also handed over.

INTENDED USE

The product only works with wood pellets and must be installed indoors.

PRODUCT PERFORMANCE CHECKS.

All our products undergo ITT TESTS carried out by a notified laboratory (system 3) and in accordance with (EU) Regulation number 305/2011 "Construction products", according to standard EN 14785:2006 (pellets) and "Machinery Directive" EN 303-5 (boilers).

In the case of tests for any market surveillance or inspections by third parties, please consider the following warnings:

- to reach the declared performance levels, the product must perform an operating cycle of at least 15/20 hours beforehand
- use the average draught of the combustion smoke specified in the "product technical specifications" table
- the type of pellets used must comply with current EN ISO 17225-2 regulations
- the amount of fuel may vary according to the length and calorific value of the fuel. This may require some adjustments to stay in line with the hourly consumption specified in the "product technical specifications" table. A1 pellets ensure an overall calorific value within tight margins compared to the test pellets used. However, size considerably affects performance, therefore on average it must not be less than 24 mm long and with a 6mm diameter
- in the case of a wood-burning product, check the correct residual moisture content of the fuel, which must not be less than 12% or more than 20%. As the moisture increases, different combustion air settings are required. The settings are to be carried out via the combustion air register, thereby modifying the mixture between primary and secondary air
- it is required to check the operation of devices that can affect performance (for example air fans or electrical safety devices) in case of damage due to handling.
- maximum performance can be achieved at the maximum flame and ventilation power.
- strictly comply with the withdrawal points required by regulations both in terms of emissions and temperature.

WARRANTY CONDITIONS

The company guarantees the product, **with the exception of parts subject to normal wear** (listed on the following page), for a period of **2 (two) years** from the date of purchase attested by:

- a document that serves as proof of purchase (invoice and/or receipt) that shows the name of the vendor and the date that the purchase was made on;
- forwarding of the completed warranty certificate within 8 days of purchase.

Furthermore, in order for the warranty to be valid, the device must be installed and calibrated by qualified personnel, and where necessary, the user must be issued with a declaration of conformity and correct product operation.

We recommend performing a functional test of the product before completion with the relative finishes, if applicable (claddings, painting of walls, etc.).

Installations that do not meet the current standards, improper use and lack of maintenance as required by the manufacturer, void the product warranty.

The warranty is valid on the condition that the instructions and warnings contained in the user and maintenance manual are observed,

1-WARNINGS AND WARRANTY CONDITIONS

and therefore the product is used correctly.

Replacement of the entire system or repair of one of its components does not extend the warranty period, and the original expiry date remains unchanged.

The warranty covers the replacement or free repair **of parts recognised as being faulty at source due to manufacturing defects.** In the event of a fault, to benefit from the warranty, the customer must keep the warranty certificate and provide it along with the document given at the time of purchase to the Technical Service Centre.

EXCLUSIONS

The warranty does not cover malfunctions and/or damage to the appliance that arise due to the following causes:

- Damage caused during transport and/or handling
- all parts that develop faults due to negligence or improper use, incorrect maintenance, installation that does not comply with the manufacturer's instructions (always refer to the installation guide provided with the appliance)
- incorrect sizing with regard to the use or faults in the installation or failure to implement the necessary measures to ensure proper execution
- improper overheating of the equipment, i.e. the use of fuels not conforming to the types and quantities indicated in the provided instructions
- further damage caused by incorrect user operations in an attempt to fix the initial fault
- worsening of the damage caused by the user continuing to operate the appliance even after the fault has been detected
- in the presence of a boiler, any corrosion, deposits or breakage caused by water flow, condensation, hardness or acidity of the water, improperly performed descaling treatments, water outage, mud or limescale deposits
- inefficiency of chimneys, flues or parts of the system affecting the appliance
- damage caused by tampering with the appliance, atmospheric agents, natural disasters, vandalism, electrical discharges, fires, faults in the electric and/or hydraulic system.
- Failure to have yearly stove maintenance performed by an authorised technician or qualified personnel shall render the warranty void.

The following are also excluded from this warranty:

- parts subject to normal wear such as gaskets, glass, cladding and cast iron grilles, painted, chrome-plated or gilded parts, handles and electric cables, bulbs, indicator lights, knobs, all parts which can be removed from the firebox.
- Variations in colour of the painted or ceramic/serpentine parts and crazed ceramics as they are natural characteristics of the material and product use.
- masonry work
- system parts (if included) not supplied by the manufacturer

Any technical operations on the product to remove the aforementioned defects and consequent damage must be agreed upon with the Technical Service Centre, who reserves the right to accept the relative job or not. However, said operations shall not be carried out under warranty but as technical support to be granted as part of any potentially and specifically agreed conditions and in accordance with the fees in force for the work to be carried out.

The user will also be charged for any costs incurred to remedy the incorrect technical operations, tampering or damage to the appliance, not attributable to original faults.

Without prejudice to the legal or regulatory limits, the warranty does not cover the containment of atmospheric and acoustic pollution.

The company declines all liability for any damage which may be caused, directly or indirectly, to persons, animals or objects as a consequence of non compliance with any provision specified in the manual, especially warnings regarding installation, use and maintenance of the appliance.

1-WARNINGS AND WARRANTY CONDITIONS

SPARE PARTS

In the event of a malfunction, consult the retailer who shall forward the call to the Technical Assistance Department. Only use original spare parts. The retailer or service centre can provide all necessary information regarding spare parts. We do not recommend waiting for the parts to get worn out before having them replaced. It is crucial to perform regular maintenance checks.



The company declines all liability if the product and any other accessory is used improperly or modified without authorisation.

All parts must be replaced with original spare parts.

Information for management of waste electrical and electronic equipment containing batteries and accumulators



This symbol appears on the product, on the batteries, on the accumulators or on their packaging or on their documentation; it indicates that the product and the batteries or the accumulators included must not be collected, recycled or disposed of with household waste at the end of their service life.

Improper management of waste electrical and electronic equipment, batteries or accumulators can cause the hazardous substances contained within to leak out. In order to avoid harming the environment or health, the user is required to separate this equipment, and/or the batteries or accumulators included, from other types of waste and deliver them to the local collection centre. The distributor can be asked to collect the waste electrical and electronic equipment under the conditions and according to the procedures laid down by Legislative Decree 49/2014.

Separate collection and correct treatment of waste electrical and electronic equipment, batteries and accumulators contribute to conserving natural resources, respect for the environment and ensure the protection of health.

For more information on collection centres for waste electrical and electronic equipment, batteries and accumulators, contact the competent public Authorities for issue of the authorisations.

WHY SEALED

Products built with a perfectly sealed structure do not consume the room's oxygen but draw all the air from the outer environment (if suitably ducted) and may therefore be installed in all houses that require a high degree of insulation such as "passive" or "high energy efficiency" houses. Thanks to this technology there is no risk of smoke emissions in the room, hence no air inlets and relevant ventilation grilles are required in the installation premises.

Consequently, there will be no more draughts of cold air in the room, which would otherwise make it less comfortable and reduce the overall efficiency of the system. The sealed stove may even be installed in the presence of forced ventilation or in premises that might have negative pressure with respect to the outside.

1-WARNINGS AND WARRANTY CONDITIONS

Our solid bio-combustible products, (hereinafter called "Products") are designed and manufactured in compliance with one of the following European standard harmonised to Regulation (UE) no. 305/2011 for construction products:

EN 14785: "Residential space heating appliances fired by wood pellets"

EN 13240: "Roomheaters fired by solid fuel"

EN 13229: "Inset appliances including open fires fired by solid fuels"

EN 12815: "Residential cookers fired by solid fuel"

The products also comply with the essential requirements of Directive **2009/125/EC (Eco Design)** and, where applicable, Directives:

2014/35/EU (LVD - Low Voltage directive)

2014/30/EU (EMC - Electromagnetic Compatibility directive)

2014/53/EU (RED – Radio Equipment directive)

2011/65/EU (RoHS)

Having specified the above, we highlight and report that:

- **This manual and technical data sheet, also available on our website**, bear all of the specific indications and necessary and essential information to choose the product, to install it correctly and to properly size the smoke expulsion system;
- the Products must be **installed, controlled and serviced** by qualified personnel, according to the instructions in this manual and in compliance with local laws and installation and maintenance standards in force in individual countries, so as to provide an efficient heating system, properly sized according to the needs of the home;
- **if the Products are thermally stressed**, constantly operating for several hours at high power (e.g. 3, 4 hours a day at outputs P4 or P5), we recommend more frequent cleaning and reducing the interval between routine maintenance operations according to the operating condition of the product. We furthermore point out that these operating conditions increase the risk of premature wear of the product, especially those parts exposed to the direct heat of the fire (e.g. combustion chamber), the original condition of which can undergo modifications and deterioration which, among other things, could generate noise during operation of the unit due to mechanical expansion.

The manufacturer will not be held liable if the above information is ignored.

We therefore recommend, in addition to complying with the cleaning, routine and extraordinary maintenance instructions provided, to make meticulous use of the unit using the intended Timer and modulation programs, to correctly manage the internal temperature of the structure.

2-INSTALLATION



The instructions in this chapter refer explicitly to the Italian installation regulation UNI 10683. In any case, always observe the regulations in force in the country of installation.

PELLETS

Wood pellets are manufactured by extruding sawdust which is produced during the processing of natural dried wood (without paint). The compactness of the material is guaranteed by the lignin contained in the wood itself and allows the pellets to be produced without glue or binders.

The market offers different types of pellets with characteristics that vary according to the wood mixtures. The most common diameter on the market is 6 mm (although 8 mm diameter is also available) with a length, on average, between 3 and 40 mm. A good quality pellet has a density of between 600 and 750 or more kg/cubic metres and a moisture content that accounts for 5 to 8% of its weight.

Pellets have technical advantages besides being an ecological fuel, as the wood residue is used completely, thereby achieving cleaner combustion than that of fossil fuels.

While good-quality wood has a calorific value of 4.4 kW/kg (15% moisture, after about 18 months of seasoning), that of pellets is around 4.9 kW/kg. To ensure good combustion, the pellets must be stored in a dry place and protected from dirt. Pellets are usually supplied in 15 kg bags, therefore, storing them is very convenient.



15 Kg BAG OF PELLETS

Good quality pellets guarantee good combustion, thereby decreasing harmful emissions into the atmosphere.



The poorer the quality of the fuel, the more often the internal parts of the brazier and combustion chamber need to be cleaned.

The main quality certifications for pellets currently available on the European market guarantee that the fuel complies with class A1/A2 according to ISO 17225-2 (ex EN 14961). These certifications include, for example, **ENplus**, **DINplus**, **Ö-Norm M7135**, and specifically assure that the following characteristics are complied with:

- calorific value: 4.6 - 5.3 kWh/kg.
- Water content: $\leq 10\%$ of the weight.
- Percentage of ash: max 1.2% of the weight (A1 less than 0.7%).
- Diameter: $6 \pm 1/8 \pm 1$ mm.
- Length: 3-40 mm.
- Content: 100% untreated wood without the addition of binding agents (max 5% bark).
- Packaging: in sacks made from ecologically compatible or biologically decomposing material.



The company strongly recommends using certified fuel for its products (ENplus, DINplus, Ö-Norm M7135). Poor quality pellets or others that do not comply with the characteristics specified previously may compromise the operation of your product and can therefore make the guarantee and product liability invalid.

2-INSTALLATION

FOREWORD

The installation position must be chosen according to the room, smoke extraction system and flue. Check with local authorities whether there are any more restrictive regulations in force regarding the combustion air inlet, the smoke outlet system, the flue or the chimney pot. The manufacturer declines all responsibility in the event of installations that do not comply with the laws in force, incorrect room air exchange, electrical connection non-compliant with the standards and inappropriate use of the appliance. The installation must be carried out by a qualified technician, who must issue a declaration of conformity of the system to the purchaser and shall assume full responsibility for final installation and consequent good operation of the product.

In particular one must ensure that:

- there is a suitable combustion air inlet and smoke outlet in compliance with the type of product installed
- other stoves or devices installed do not cause negative pressure in the room where the product is installed (for sealed appliances only, a maximum of 15 Pa of negative pressure in the room is allowed)
- when the product is switched on there is no reflux of smoke in the room
- smoke extraction takes place in full safety (sizing, smoke seal, distances from flammable materials...).

We especially recommend checking the data plates of the flue for the safety distances that must be observed in the presence of combustible materials and the type of insulating material to be used. These indications must be followed strictly to prevent serious harm to people and to the integrity of the home. Installation of the appliance must ensure easy access to clean the appliance itself, the smoke outlet pipes and the flue. **It is forbidden to install the stove in rooms with a fire hazard. Installation in studio flats, bedrooms and bathrooms is only permitted with sealed or closed appliances equipped with suitable combustion air ducting directly outside. Always maintain adequate distance and protection in order to prevent the product from coming into contact with water.**

If there are several appliances installed, the external air inlet must be sized accordingly.

MINIMUM DISTANCES

It is recommended to install the stove detached from any walls and/or furniture, with a minimum clearance to allow effective aeration of the appliance and a good distribution of heat in the room. Comply with the distances from flammable or heat-sensitive objects (sofas, furniture, wood panelling, etc.) as specified below. The frontal distance from flammable materials must be at least as specified in the product's technical data table.

If there are particularly delicate objects such as furniture, curtains or sofas, increase the stove distance accordingly.



If the floor is made of wood, it is recommended to fit a floor protection sheet in compliance with the standards in force in the country of installation.

| MAY AIR 7 S1/ MAY AIR 7 UP! S1 | Non-flammable walls | Flammable walls |
|-----------------------------------|----------------------|------------------------|
| | A = 5 cm B = 5 cm | A = 20 cm B = 30 cm |

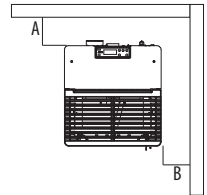

If the floor is made of combustible material, it is recommended to use a protection made of non-combustible material (steel, glass...) that also protects the front from any falling combusted material during cleaning operations.

The appliance must be installed on a floor with adequate load capacity.

If the existing construction does not meet this requirement, appropriate measures must be taken (for example a load distribution plate).

2-INSTALLATION

FOREWORD

This Flue chapter has been drawn up with reference to the provisions of European Standards (EN13384 - EN1443 - EN1856 - EN1457). The chapter provides indications for installing an efficient and correct flue but is under no circumstances to substitute the regulations in force, which the qualified manufacturer must be in possession of. Check with local authorities whether there are any restrictive regulations in force regarding the combustion air inlet, the smoke outlet system, the flue or the chimneypot. The Company declines all liability relating to the poor functioning of the stove if this is due to the use of an insufficiently sized flue in violation of the standards in force.

FLUE

The flue or chimney is of great importance for the proper operation of a solid fuel-burning heating appliance with forced draught. As modern heating appliances have high efficiency with cooler flue gases and consequently less draught, it is therefore crucial for the flue to be built to professional standard and always kept in perfect working order. A flue for a pellet/wood fired appliance must be at least category T400 (or greater if the appliance requires so) and resistant to soot fires. Smoke must be extracted through a single flue made of insulated steel (A) or an existing flue that complies with the intended use (B).

A simple air shaft made of cement must be suitably piped. In both solutions there must be an inspection cap (AT) and/or inspection access panel (AP) - FIG.1.

It is prohibited to connect more than one wood/pellet appliance (*) or any other type of appliance (cowl vents ...) to the same flue.

(*) unless there are national derogations (for instance in Germany), which under suitable conditions allow for the installation of several appliances in the same fireplace. In any case, strictly follow the product/installation requirements of the relative regulations/legislation in force in that country.

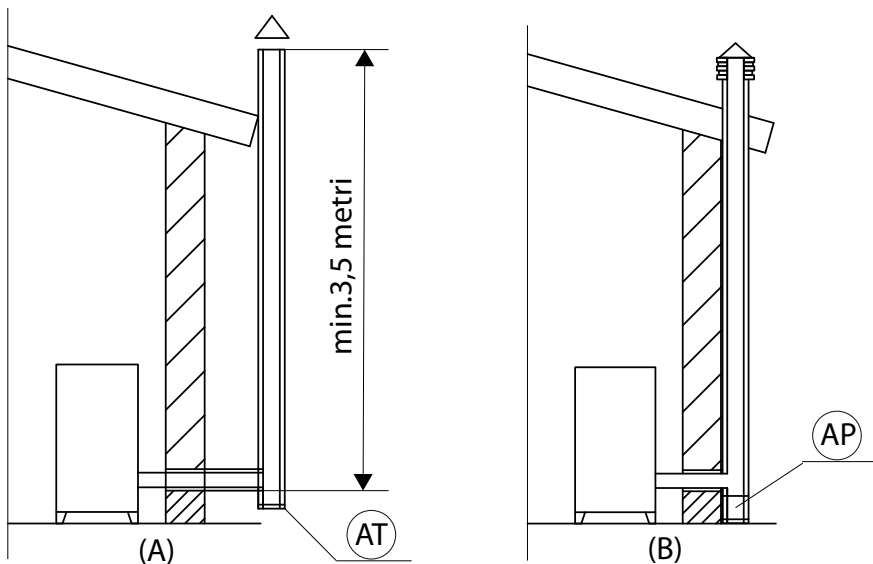

FIGURE 1 - FLUE

2-INSTALLATION

TECHNICAL SPECIFICATIONS

Have the efficiency of the flue checked by an authorised technician.

The flue must be sealed against flue gases, in a vertical direction without narrowing, be made with materials impermeable to smoke, condensation, thermally insulated and suitable to resist normal mechanical stress over time (we recommend fireplaces made of A/316 or refractory material with insulated round section double chamber). It must be suitably insulated externally to avoid condensation and reduce the smoke cooling effect. It must be separated from combustible or easily flammable materials via an air gap or insulating materials: check the distance specified by the chimney manufacturer according to EN1443. The chimney opening must be in the same room as the appliance, or at most in the adjoining room, and have a soot and condensation collection chamber beneath the opening, and be accessible via a sealed metal door.

FLAT ROOF

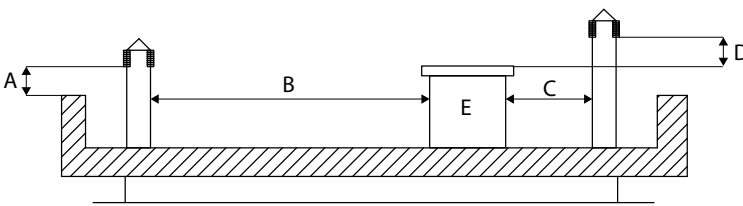

- A = 0.50 metres
- B = DISTANCE > 2 metres
- C = DISTANCE < 2 metres
- D = 0.50 metres
- E = TECHNICAL VOLUME

FIGURE 2

ROOF AT 15°

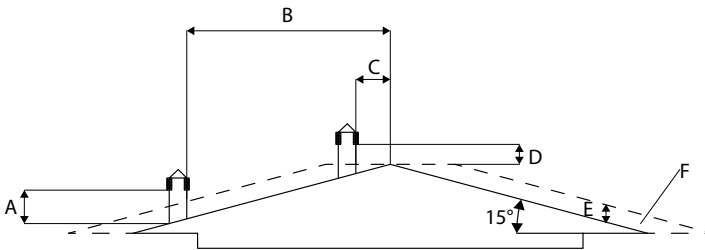

- A = MIN. 1.00 metre
- B = DISTANCE > 1.85 metres
- C = DISTANCE < 1.85 metres
- D = 0.50 metres ABOVE HIGHEST POINT
- E = 0.50 metres
- F = REFLUX AREA

FIGURE 3

ROOF AT 30°

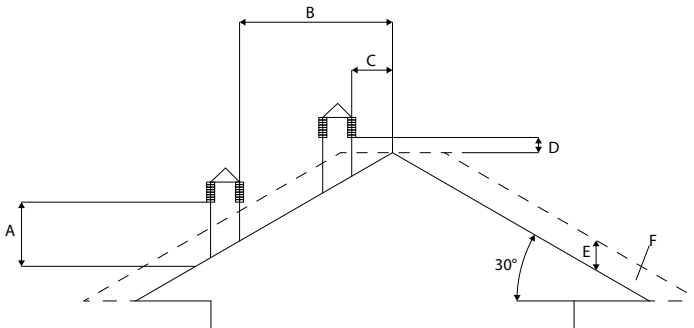

- A = MIN. 1.30 metres
- B = DISTANCE > 1.50 metres
- C = DISTANCE < 1.50 metres
- D = 0.50 metres ABOVE HIGHEST POINT
- E = 0.80 metres
- F = REFLUX AREA

FIGURE 4

2-INSTALLATION

ROOF AT 60°

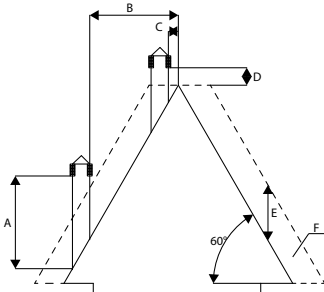

FIGURE 5

- A = MIN. 2.60 metres
- B = DISTANCE > 1.20 metres
- C = DISTANCE < 1.20 metres
- D = 0.50 metres ABOVE HIGHEST POINT
- E = 2.10 metres
- F = REFLUX AREA

ROOF AT 45°

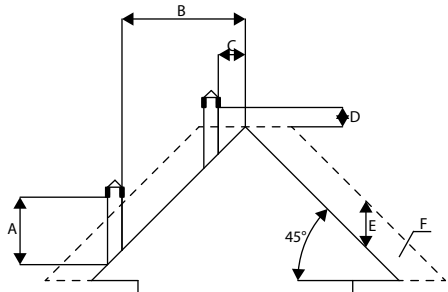

FIGURE 6

- A = MIN. 2.00 metres
- B = DISTANCE > 1.30 metres
- C = DISTANCE < 1.30 metres
- D = 0.50 metres ABOVE HIGHEST POINT
- E = 1.50 metres
- F = REFLUX AREA

SIZING

The negative pressure (draught) of a flue also depends on its height. Check the negative pressure with the values indicated in the technical specifications. The minimum height of the chimney is 3.5 metres.

The interior cross-section of the flue can be round (best solution), square or rectangular (the ratio between the internal sides must be ≤ 1.5) with the sides joined with a minimum radius of 20 mm. The dimension of the cross-section must be **minimum $\varnothing 100\text{mm}$** .

The cross-sections/lengths of the chimneys shown in the technical data tables are indications for correct installation. Any alternative configurations must be correctly sized in accordance with the general method of calculation of UNI EN13384-1 or other proven efficiency methods.

Some examples of flues available on the market are provided below:

AISI 316 steel chimney with double chamber insulated with ceramic fibre or equivalent resistant up to 400°C.

Refractory chimney with double insulated chamber and external lightweight concrete cladding with cellular material such as clay.

Traditional square-section clay chimney with insulating empty inserts.

Avoid products with an internal rectangular section where the larger side is 1.5 times the smaller side (e.g. 20x40 or 15x30).

EXCELLENT

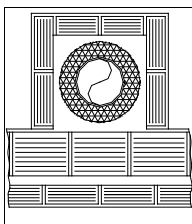

GOOD

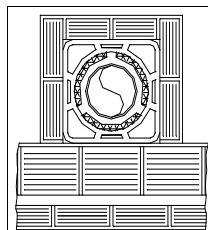

POOR

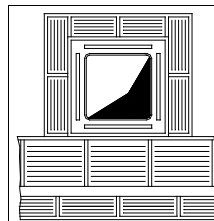

VERY POOR

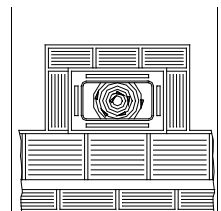

2-INSTALLATION

MAINTENANCE

The flue must be kept clean, since the deposit of soot or unburnt oils reduces the cross-section, blocking the draught and thus compromising the efficient operation of the stove and, if large build-ups accumulate, can catch fire. The flue and chimneypot must be cleaned and checked by a qualified chimney sweep at least once a year. Once the inspection/maintenance has been performed, request a written report that the system is safe.

Failure to perform cleaning jeopardises the system's safety.

CHIMNEYPOT

The chimneypot is a crucial element for correct operation of the heating appliance: we recommend a windproof chimneypot (A), see Figure 7.

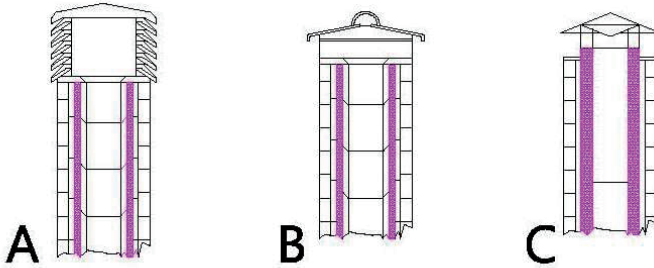

The area of the opening for smoke extraction must be at least double the cross-section of the flue/piped system, and arranged so that the smoke outlet is ensured even in the presence of strong wind. The chimneypot must prevent rain, snow or animals from entering the chimney. The height of outflow into the atmosphere must be beyond the reflux area caused by the shape of the roof or any nearby obstacles (see Figures 2-3-4-5-6).

FIGURE 7

CHIMNEY COMPONENTS

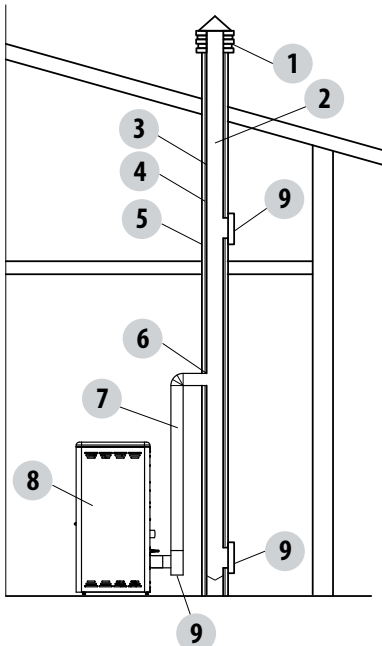

- KEY:
- (1) CHIMNEYPOT
 - (2) REFLUX CHANNEL
 - (3) SMOKE DUCT
 - (4) THERMAL INSULATION
 - (5) OUTSIDE WALL
 - (6) CHIMNEY FITTING
 - (7) SMOKE DUCT
 - (8) HEAT GENERATOR
 - (9) INSPECTION ACCESS PANEL

FIGURE 8

2-INSTALLATION

EXTERNAL AIR INLET

It is mandatory to provide an adequate external air inlet that supplies the combustion air required for the product to work properly. The flow of air between the outside and the installation room may be direct, through an inlet in an external wall of the room (preferable solution see Figure 9 a), or indirect, via air intake from adjoining rooms and connecting permanently with the installation room (see Figure 9 b). Adjoining areas may not include sleeping areas, bathrooms, garages or in general areas with a fire hazard. During installation it is required to check the minimum clearances required to draw air from outside. Take into account the presence of doors and windows that could interfere with the proper flow of air to the stove (see diagram below).

The air inlet must have a minimum net total area of 80 cm²: the surface must be increased accordingly if there are other active generators (for example: electric fan for stale air extraction, range cooker hood, other stoves, etc.), which could cause a depression in the room. Make sure that, with all appliances on, the pressure drop between the room and the outside does not exceed the value of 4 Pa (also for Oyster appliances if the combustion air has not been suitably ducted outside). If required, increase the intake section of the air inlet, which must be made at floor level and always protected with a bird-proof outer protection grid and in such a way that it cannot be obstructed by any object.

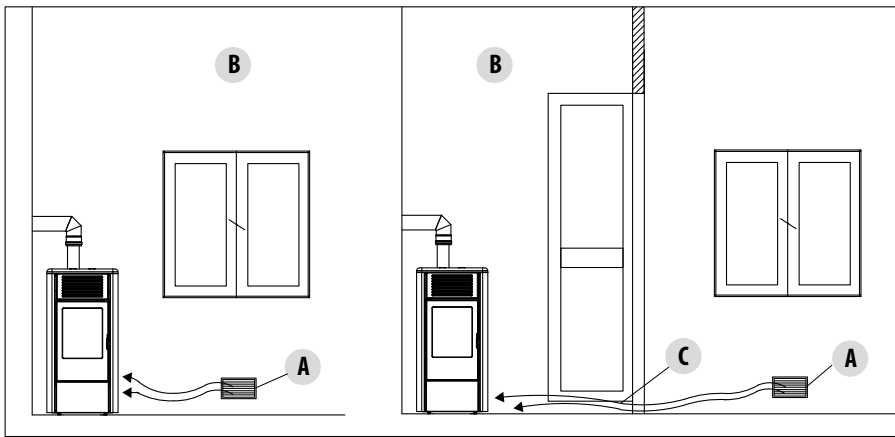

FIGURE 9 A - DIRECTLY FROM OUTSIDE

FIGURE 9 B - INDIRECTLY FROM THE ADJACENT ROOM

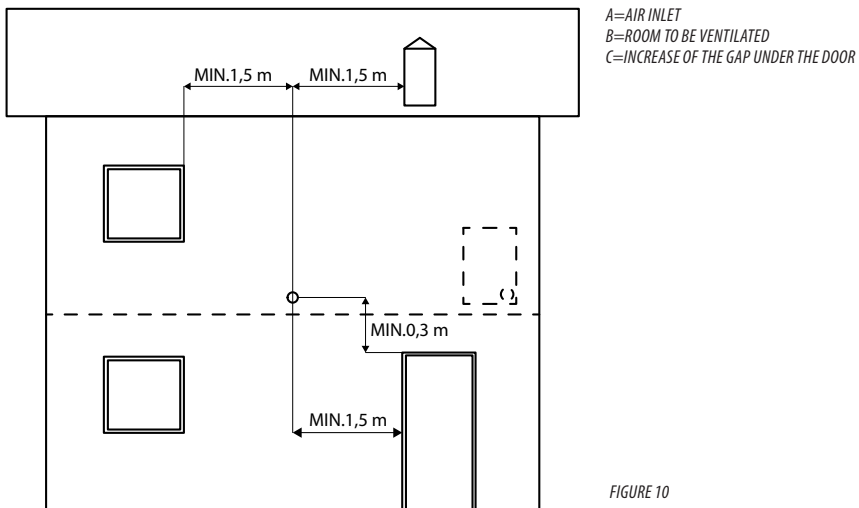

FIGURE 10

2-INSTALLATION

In order to fully enhance the sealed features and heating performance of this Oyster appliance, and thus to avoid fitting a free air intake in the room. It is recommended to connect the air required for combustion directly to the external air intake through Ø60 mm piping with a maximum length of 3 linear metres, using the suitable “j” 048/60 adapter supplied with the appliance; each pipe elbow must be considered as equivalent to one linear metre. If a longer connection should be required, increase further with an Ø80 mm smooth pipe. However, do not exceed 8 linear metres of ducting (considering the curves too). In sealed stoves the connection must be sealed in order not to affect the overall sealed features of the system.

For stoves installed in studio flats, bedrooms and bathrooms (where allowed), it is mandatory to connect the combustion air outside.

| DISTANCE (metres) | The air inlet must be at a distance of: | |
|-------------------|---|---|
| 1.5 m | BELOW | Doors, windows, smoke outlets, gaps, |
| 1.5 m | HORIZONTALLY | Doors, windows, smoke outlets, gaps, |
| 0.3 m | ABOVE | Doors, windows, smoke outlets, gaps, |
| 1.5 m | AT A DISTANCE | from smoke outlet |

CONNECTION TO THE FLUE

The connection between the flue and the appliance must be via a smoke duct that complies with EN 1856-2. The connecting section must extend no more than 4 m horizontally, with a minimum slope of 3% and with a maximum of 3 90° bends (accessible for inspection - do not count the T fitting at the appliance outlet).

The diameter of the smoke duct must be equal to or greater than that of the outlet of the appliance (Ø 80 mm).

| TYPE OF SYSTEM | SMOKE DUCT |
|---|------------|
| Maximum length (with 1 accessible 90° bend) | 6.5 metres |
| Maximum length (with 3 accessible 90° bends) | 4.5 metres |
| Maximum number of accessible 90° bends | 3 |
| Horizontal sections (minimum slope 3%) | 4 metres |

Use smoke ducts with a diameter of 80mm or 100mm depending on the type of system, with silicone gaskets or similar sealing devices that can withstand the high operating temperatures of the appliance (min. T200 class P1). **The use of flexible metal tubes made of fibre cement or aluminium is forbidden. For direction changes, we always recommend the use of a Tee fitting** with an inspection cap ensuring easy access to clean the pipes. Always ensure that the inspection cap is put back in place and sealed hermetically with the relevant seal intact after cleaning.

It is prohibited to connect more than one appliance to the same smoke duct, or the discharge from hoods above it. It is forbidden to extract the combustion products directly through the wall, whether towards indoor spaces or outdoors.

The smoke duct must be at a minimum distance of 400 mm from flammable or heat-sensitive structures.

2-INSTALLATION

EXAMPLES OF CORRECT INSTALLATION

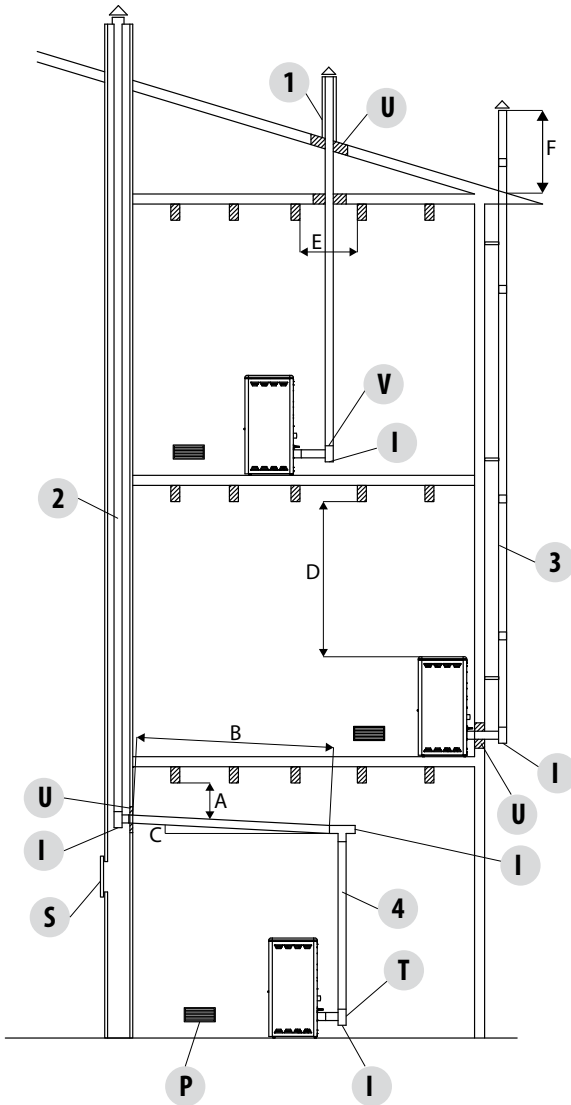

1. Installation of $\varnothing 120\text{mm}$ flue with hole for the passage of the pipe increased by:
 minimum 100mm around the pipe if next to non-flammable parts such as cement, brick, etc.; or
 minimum 300mm around the pipe (or as required by plate data) if next to flammable parts such as wood etc.
 In both cases, install suitable insulation between the flue and the ceiling.

Always check and comply with the plate data of the flue, specifically the minimum safety distances from combustible materials.

The previous rules also apply for holes made in walls.

2. Old flue, minimum pipe $\varnothing 100\text{mm}$ with the inclusion of an external access door for chimney cleaning.

3. External flue made of insulated stainless-steel pipes, i.e. with double walls minimum $\varnothing 100\text{mm}$: all securely mounted on the wall. With windproof chimneypot. See fig. 7 type A.

4. Ducting system using Tee fittings that allow easy access for cleaning without having to remove the pipes

FIGURE 11

U = INSULATION
 V = ANY REDUCTION FROM 100 TO 80 MM
 I = INSPECTION CAP
 S = INSPECTION ACCESS PANEL
 P = AIR INLET
 T = TEE FITTING WITH INSPECTION CAP

A = MINIMUM 40 MM
 B = MAXIMUM 4 M
 C = MINIMUM 3°
 D = MINIMUM 400 MM
 E = HOLE DIAMETER
 F = SEE FIG.2-3-4-5-6

3-DRAWINGS AND TECHNICAL SPECIFICATIONS

DRAWINGS AND CHARACTERISTICS

MAY AIR 7 S1 STOVE DIMENSIONS

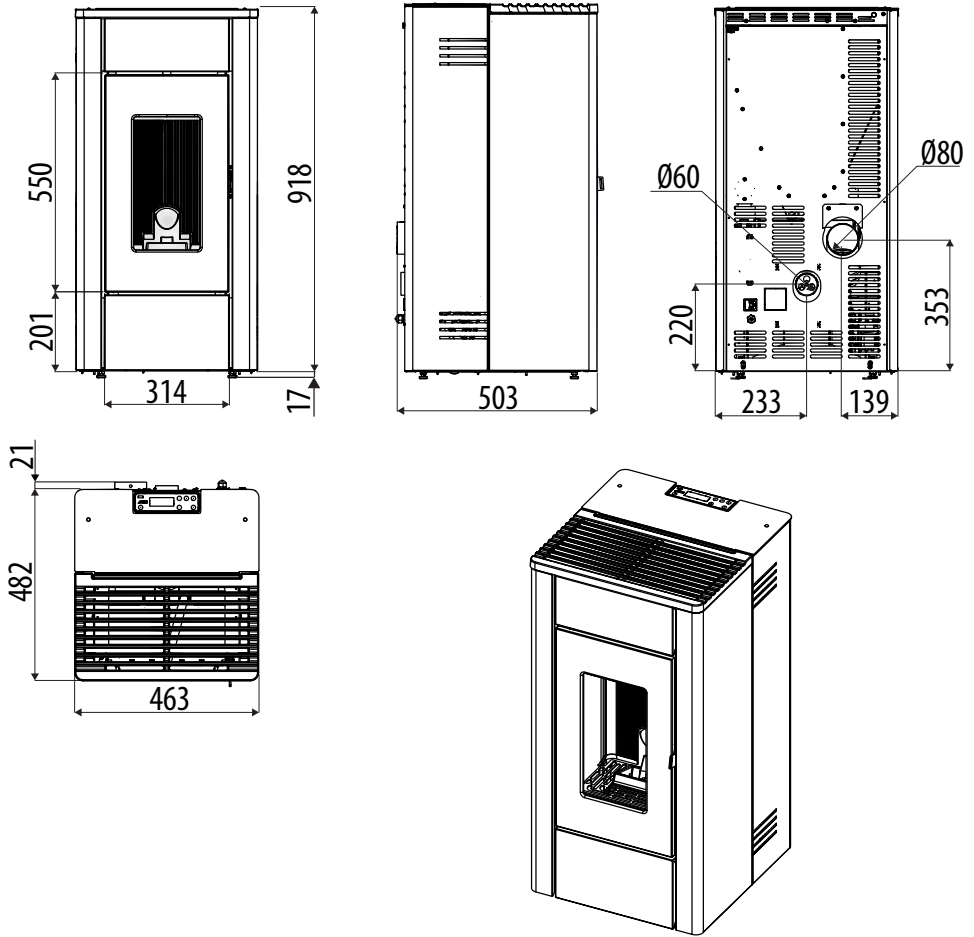

3-DRAWINGS AND TECHNICAL SPECIFICATIONS

MAY AIR 7 UP! STOVE DIMENSIONS S1

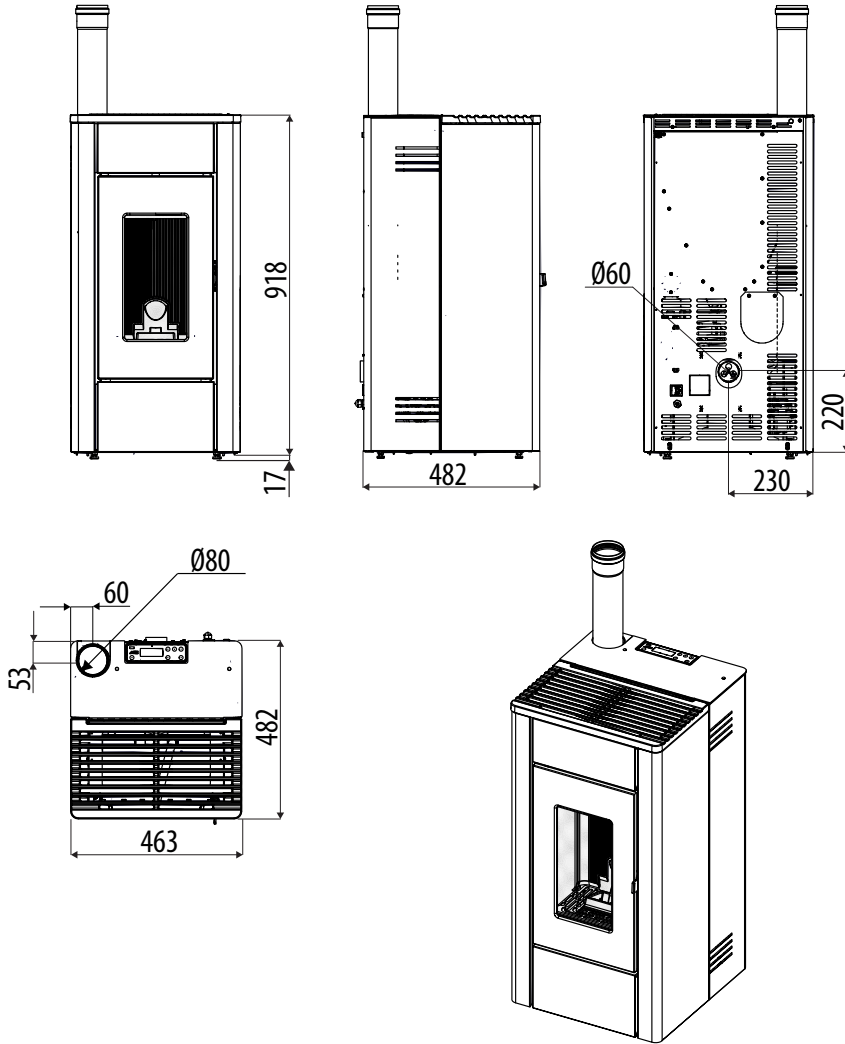

3-DRAWINGS AND TECHNICAL SPECIFICATIONS

| TECHNICAL SPECIFICATIONS | MAY AIR 7 S1 / MAY AIR 7 UP! S1 |
|--|---|
| Energy Efficiency Class | A+ |
| Nominal output power | 7.0 kW (6020 kcal/h) |
| Minimum output power | 2.5 kW (2150 kcal/h) |
| Efficiency at Max | 90.5% |
| Efficiency at Min | 95.0% |
| Temperature of exhaust smoke at Max | 193 °C ⁽¹⁾ |
| Temperature of exhaust smoke at Min | 88 °C ⁽¹⁾ |
| Particulate / OGC / Nox (13%O ₂) | 15 mg/Nm ³ - 4 mg/Nm ³ - 112 mg/Nm ³ |
| CO at 13% O ₂ at Min and at Max | 0.016 – 0.013% |
| CO ₂ at Min and at Max | 7.6% - 12.5% |
| Recommended draught at Max power | 0.10 mbar - 10 Pa*** |
| Minimum draught allowed at minimum power | 0.05 mbar - 5 Pa |
| Smoke mass | 4.7 g/sec |
| Hopper capacity | 26 litres |
| Type of pellet fuel | Pellet diameter 6 mm and size 3 - 40 mm |
| Pellet hourly consumption | Min ~ 0.56 kg/h* - Max ~ 1.67 kg/h* |
| Autonomy | At min ~ 30 h* - At max ~ 10 h* |
| Heatable volume m ³ | 151/40 – 172/35 – 201/30 ** |
| Combustion air inlet | Ø 60 mm |
| Smoke outlet | Ø 80 mm |
| Air inlet | 80 cm ² |
| Rated electrical power (EN 60335-1) | 49 W (Max 345 W) |
| Supply voltage and frequency | 230 Volt / 50 Hz |
| Net weight | 80 kg |
| Weight with packaging | 95 kg |
| Distance from combustible material (back/side/under) | 200 mm /300 mm / 0 mm |
| Distance from combustibile material (ceiling/front) | 800 mm / 1000 mm |

* Data that may vary depending on the type of pellets used

** Volume that can be heated, according to the power requirement per m³ (respectively 40-35-30 Kcal/h per m³)

***Value recommended by the manufacturer (non-binding) for optimal product operation

Tested according to EN 14785 in accordance with European regulation for Construction Products (EU 305/2011)

⁽¹⁾ To properly size the chimney (in accordance with EN 13884-1), use the smoke temperature exactly detected at the outlet of the appliance, or the above stated temperature increased by 20% (e.g. stated temperature 100°C: product outlet temperature 120°C)

3-DRAWINGS AND TECHNICAL SPECIFICATIONS

PREPARATION AND UNPACKING

Remove all the parts of the packaging (polystyrene, wood, plastic). All packaging materials can be reused for similar use or disposed of as urban solid waste, in accordance with the standards in force.

After having removed the packaging make sure the product is intact.



Handle the product with suitable means paying attention to the applicable safety regulations in force. Do not turn the packaging over and handle the majolica parts with care.

The stove is delivered in a single package. Open the package, remove the two screws “v” which secure the stove brackets to the pallet and then remove the bracket “S” from the stove foot. There are four brackets, two at the front and two at the back.

Install the stove in the chosen area, making sure it complies with the requirements.

The stove body or unit must always be kept in a vertical position when handled, and handled using trolleys only. Pay particular attention to the door and its glass, protecting them from mechanical knocks that would compromise their integrity.

The product must always be handled with care. If possible, unwrap the stove near the chosen area of installation. The packaging materials are neither toxic nor harmful, therefore no particular disposal measures are required.

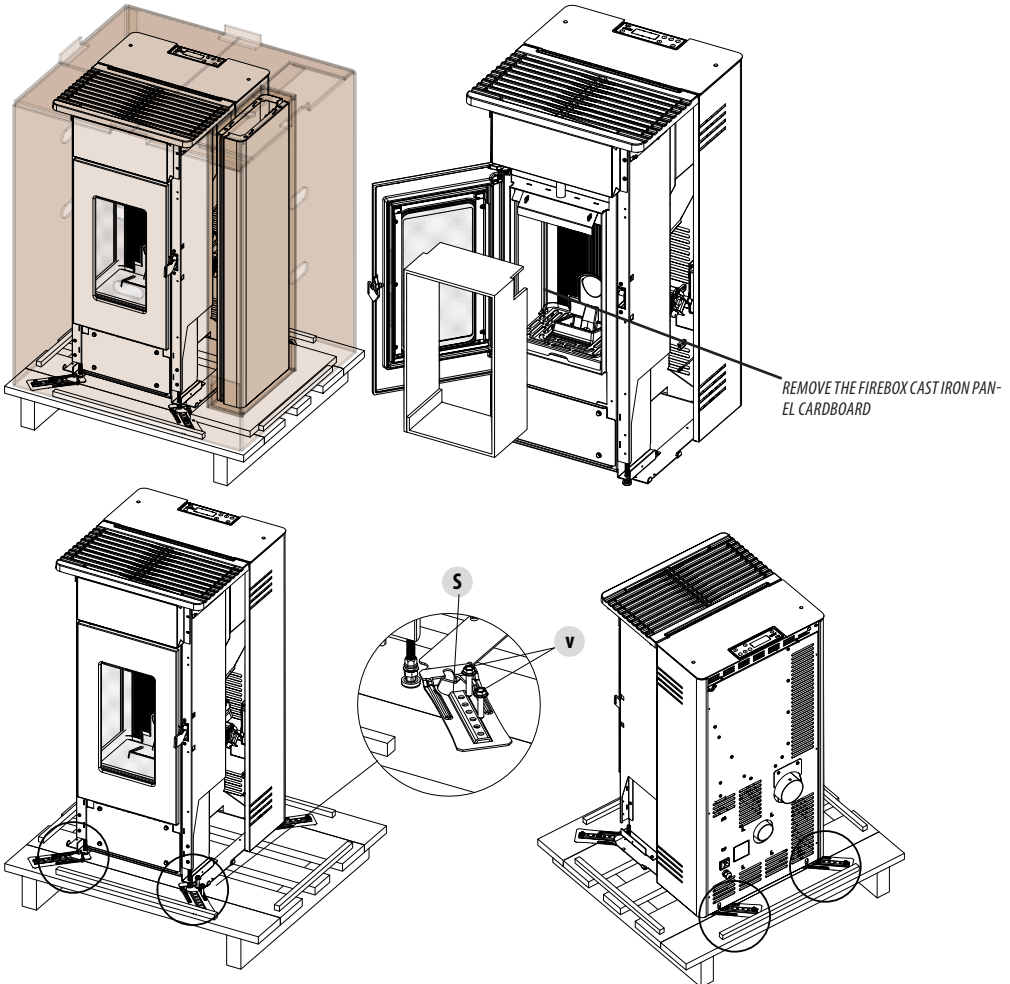

3-DRAWINGS AND TECHNICAL SPECIFICATIONS

Therefore, the end user is responsible for product storage, disposal or possible recycling in compliance with the relative applicable laws in force. Do not store the stove unit or its cladding without their packaging.

Position the stove and connect it to the flue. Remove the plastic tie that fastens the top to the structure of the stove.
If the stove needs to be connected to an outlet pipe which goes through the rear wall (to connect to the flue), take utmost care to make sure that the joint is not forced.



If the stove smoke outlet is forced or used improperly to lift it or position it, the operation of the stove can be damaged irreparably.

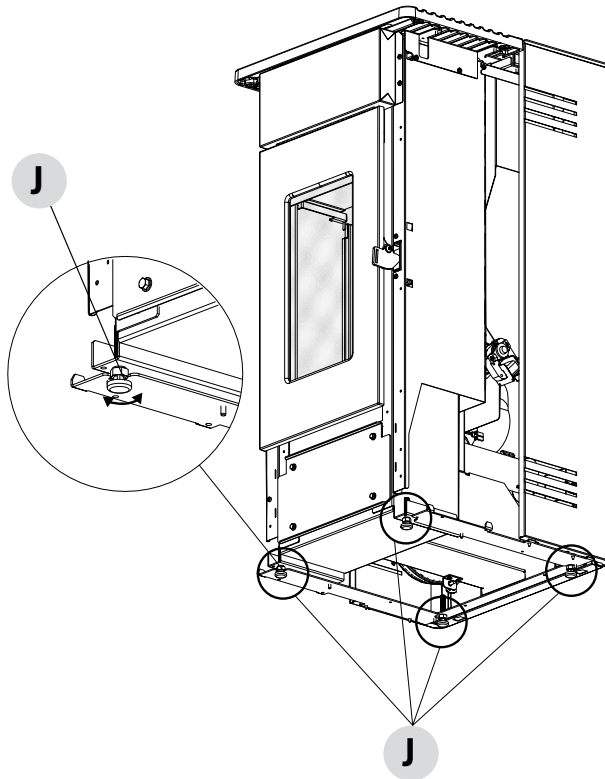

1. TURN THE FEET CLOCKWISE TO LOWER THE STOVE
2. TURN THE FEET ANTICLOCKWISE TO RAISE THE STOVE

5- SMOKE OUTLET

REAR SMOKE OUTLET (MAY AIR 7 S1)

The stove will leave the factory as per standard with the elbow for the rear outlet as shown in the image below.
When installing with rear outlet, connect the external smoke pipe to the stove

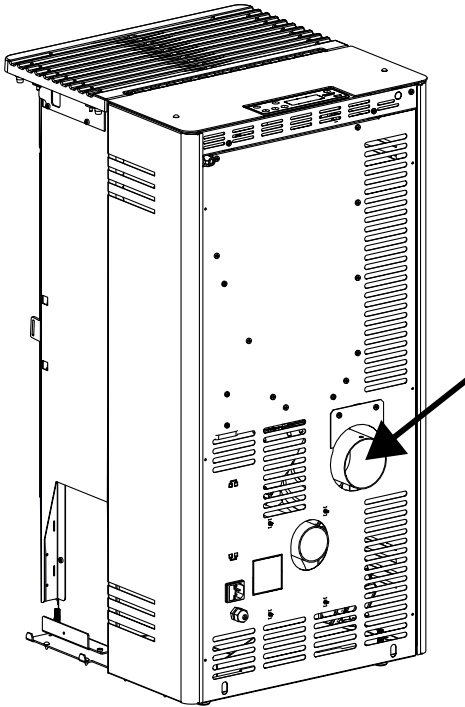

5- SMOKE OUTLET

TOP SMOKE OUTLET (MAY AIR 7 UP! S1)

Preliminary steps:

- prepare the components of the top smoke outlet kit
- leave the stove without claddings (including rear panels)

KIT CONTENTS

| POS. | DESCRIPTION | No. | POS. | DESCRIPTION | No. |
|------|-------------------------|-----|------|------------------------|-----|
| B | COMPLETE PELLET COVER | 1 | g | TEE FITTING CAP GASKET | 1 |
| S | REAR OUTLET CLOSING CAP | 1 | P | BLACK OPEN CAP | 1 |
| z | M4X12 SCREW | 2 | y | M6 FLAT WASHER | 2 |
| R | PIPE DIAM.8 | 1 | k | M4 6S NUT | 2 |
| Q | TEE FITTING CAP | 1 | w | SCREW M4,2X13 | 1 |

The first step is to remove the top "A" installed as per standard in the stove.

Proceed as follows:

- lift the top "A"
- remove the two screws "x" (keep them "x" to install the pellet cover "B" of the kit 4020001)
- remove the top "A"

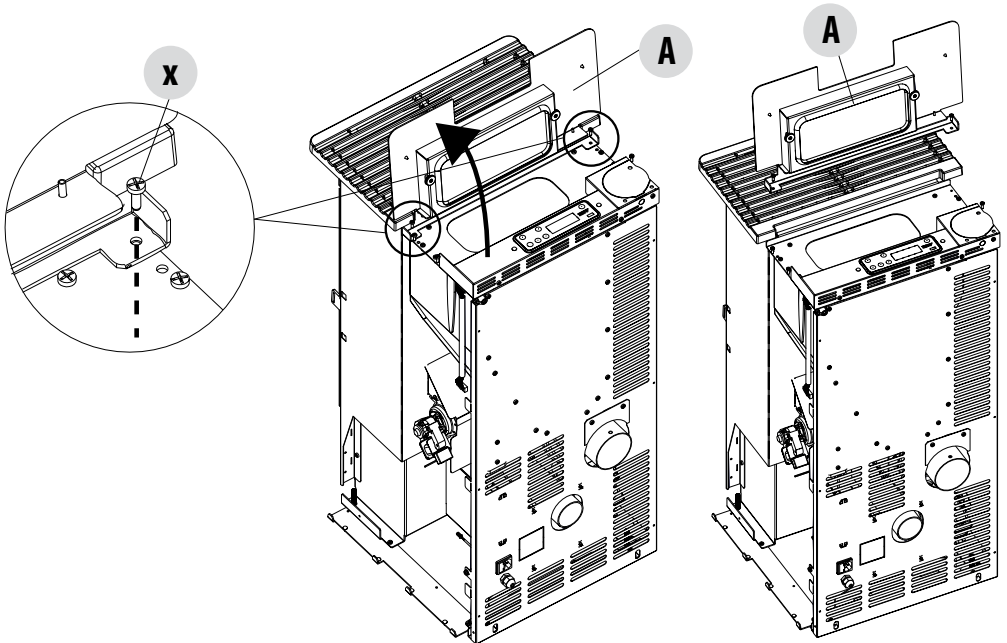

5- SMOKE OUTLET

- remove the elbow "H"

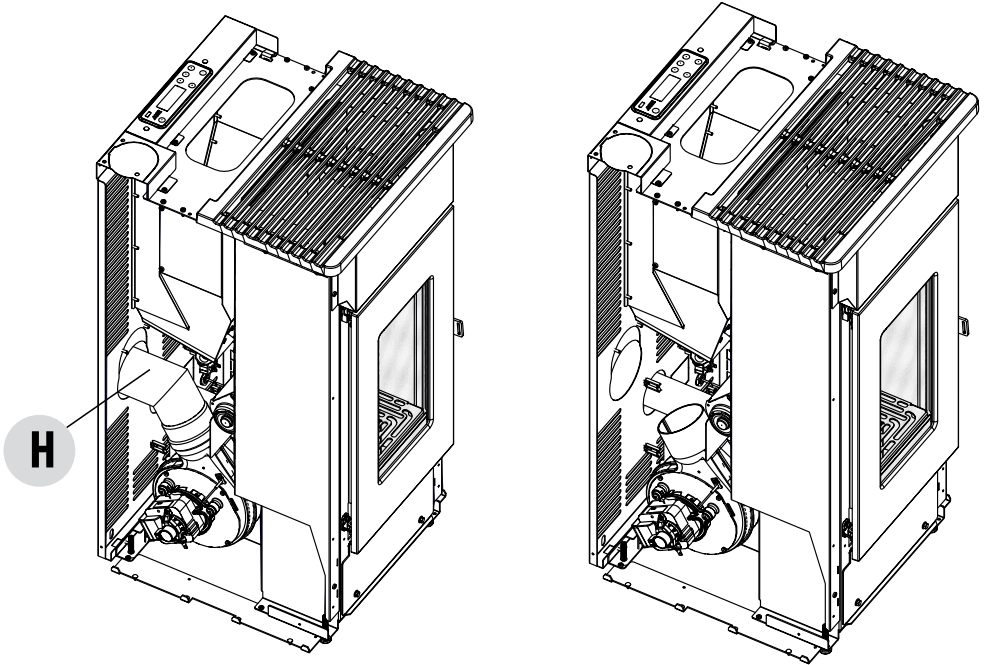

- mount the fitting "L", the gasket "g" and the cap "Q" for top outlet

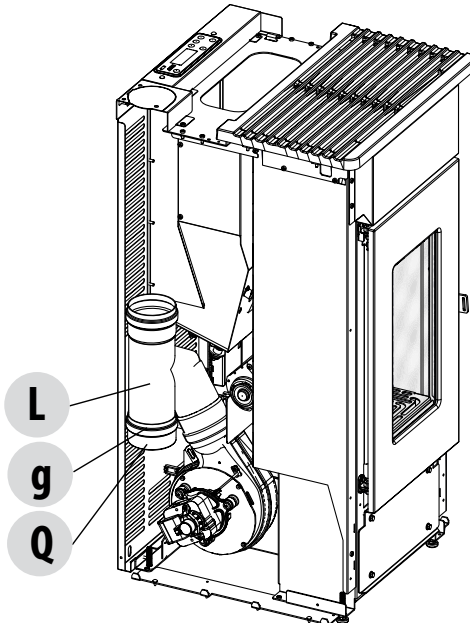

5- SMOKE OUTLET

- remove the knockout hole "S"
- take the cap "P" from the kit
- fix the cap "P" to the stove with the nuts "k" (nut M4 6S)
- between the cap "P" and the stove structure, position the two washers "y" (washer for M6)

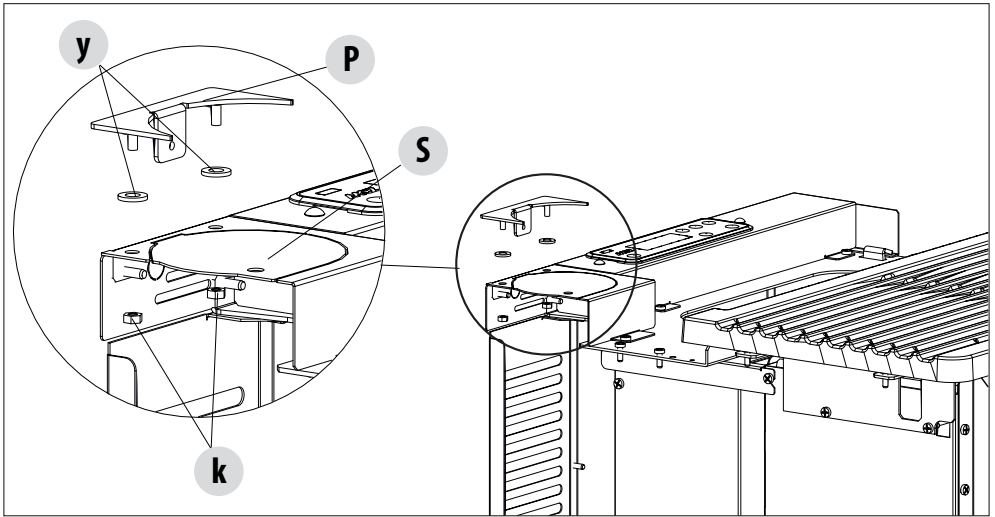

- mount the linear pipe "U" (optional) on the fitting "L"

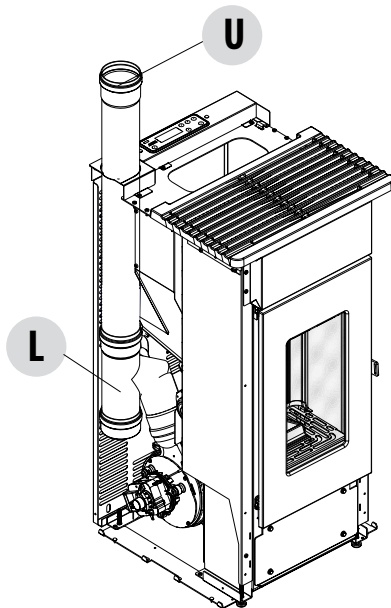

5- SMOKE OUTLET

- punch the knockout hole "Q"
- fix the pipe "U" with the screw "w" (self tapping screw 4.2x13)



Before fixing the pipe "U" with the screw "w" centre the pipe with respect to the insertion hole, otherwise the hopper cover might not open.

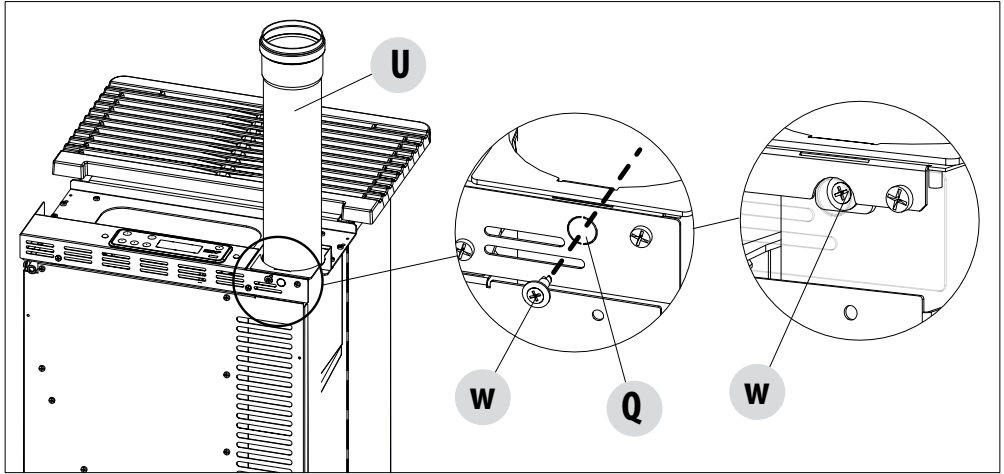

- Fasten the cap "S" at the back with the two screws "z"

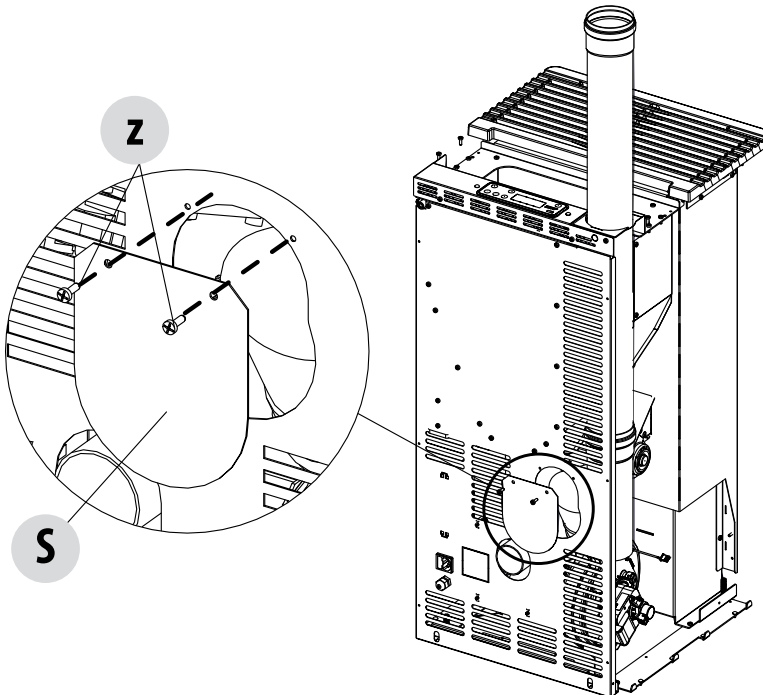

5- SMOKE OUTLET

- take the pellet cover "B" (included in the kit)
- use the 2 screws "x" taken out for removal of the cover "A" (self tapping screw M4x12)

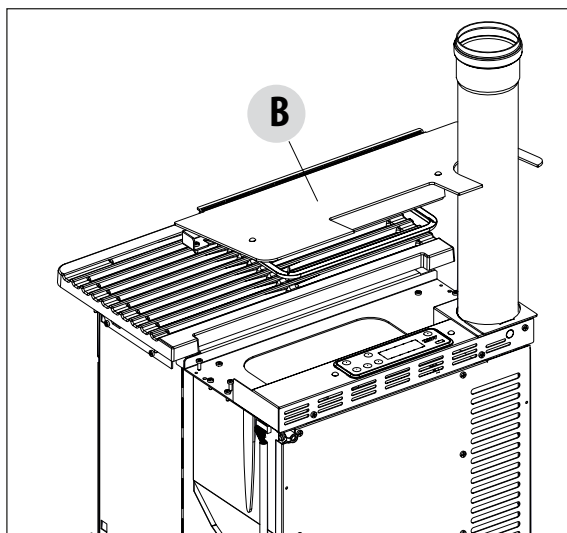

- fasten the cover "B" to the structure with the two screws "x"



Attention! The cup (end part of the linear pipe) must be **AT LEAST 200 mm** from the stove cover as indicated in the drawing below; otherwise it would interfere with opening of the door "B". It is sufficient to use a 1 m long linear pipe.

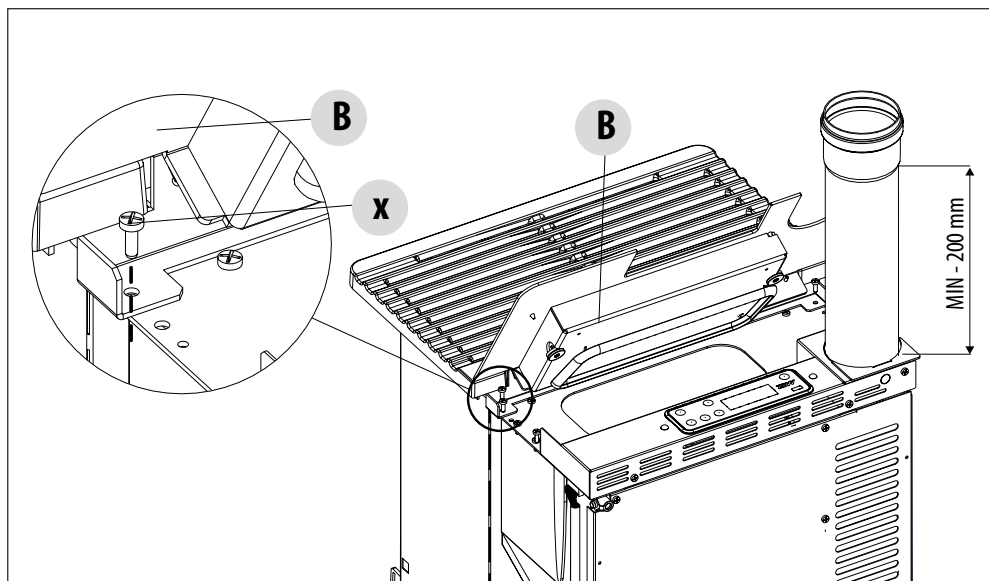

6-INSTALLATION AND ASSEMBLY



Live electrical parts: only power the product once it has been fully assembled.

On delivery, the stove has no metal cladding, as shown in the image below.
Take the box with the package (figure below) and prepare the material for installation.

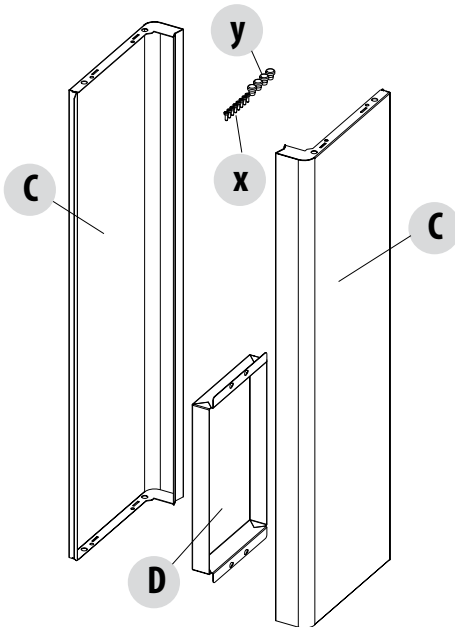
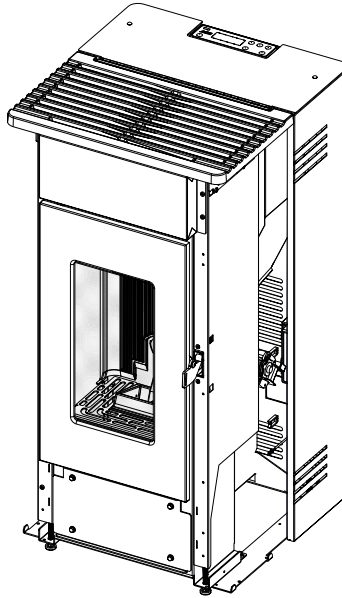

METAL CLADDING

| POS. | DESCRIPTION | No. |
|------|-------------------------|-----|
| C | FRONT METAL SIDE PANEL | 2 |
| D | FRONT LOWER METAL PANEL | 1 |
| x | M4X12 SCREW | 4 |
| y | RUBBER BUFFER | 4 |

6-INSTALLATION AND ASSEMBLY

DISASSEMBLING THE BACK PANEL

The stove is delivered with the back panels installed on the product. If you need to remove the side panels for technical service or cleaning or to install the top outlet, proceed as follows:

- lift the cover of the pellet hopper "A" or "B" (cover "A" or "B" depending on the type of installation, see previous pages)
- remove the two screws "k" securing the panel "F" to the structure
- lift the panel "F" up so that the holes "v" come out from the lower support "z" (see image on next page)
- put the panel "F" back in a safe place

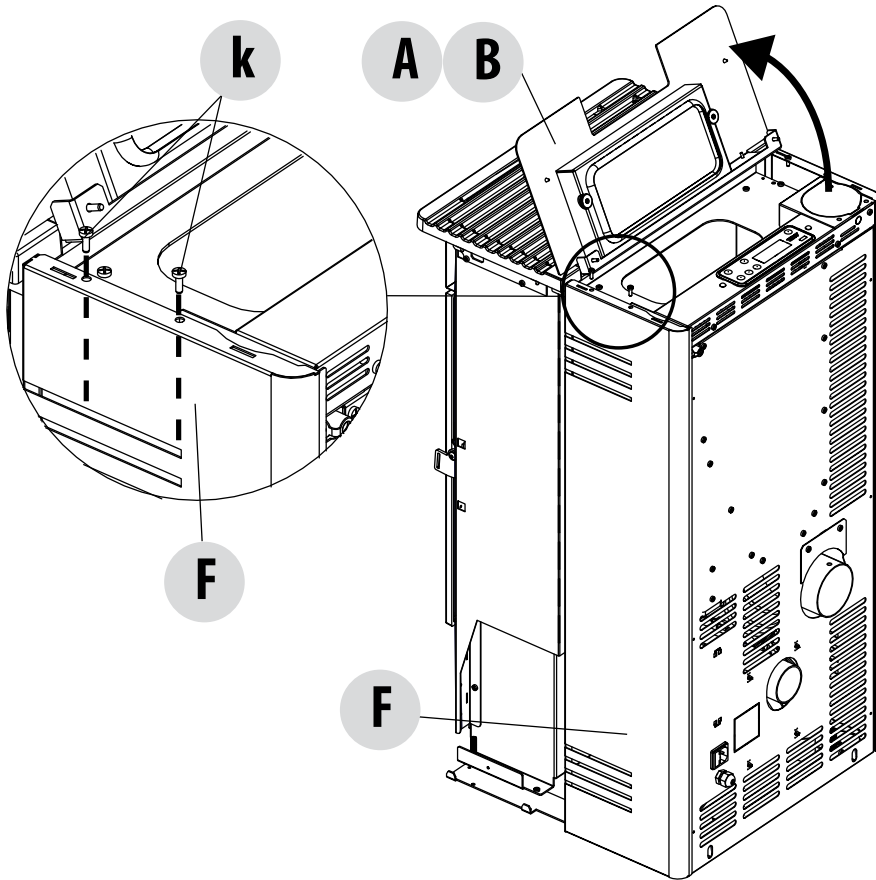

6-INSTALLATION AND ASSEMBLY

- repeat the same procedure with the other panel

To put the panels back in place, perform the same operations in the opposite order.

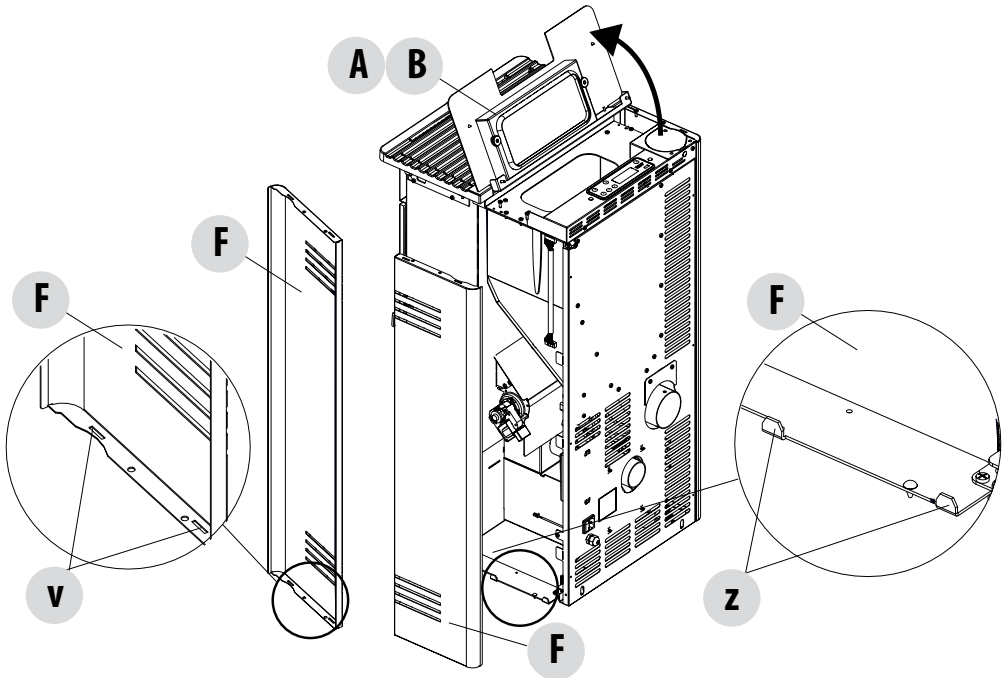

6-INSTALLATION AND ASSEMBLY

ASSEMBLING LOWER FRONT CLADDING

Before assembling the chosen side cladding, mount the lower panel "D" as follows:

- Take the lower panel "D" and the 4 screws "x" from the box
- Secure the panel "D" to the structure of the stove using the 4 screws "x"

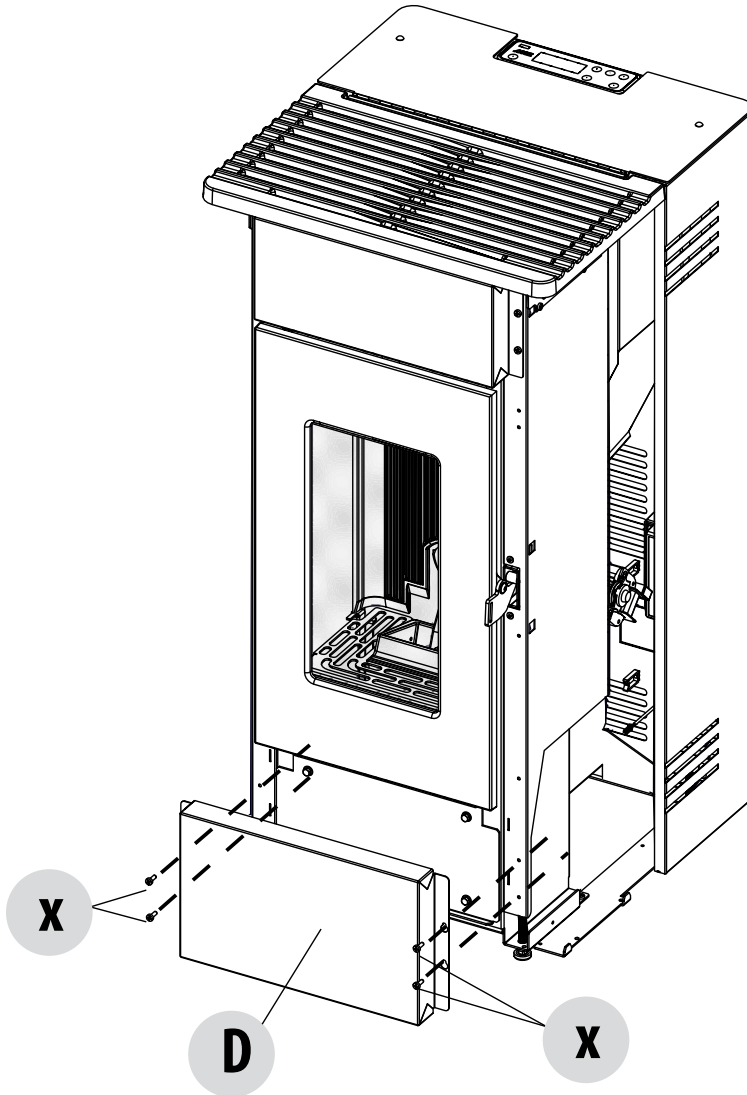

6-INSTALLATION AND ASSEMBLY

ASSEMBLING THE SIDE CLADDING

To install the side cladding, proceed as follows:

- remove the top "E" (simply lift it from its seat)
- take a panel "C" (there is no right or left as they are symmetrical) and the two rubber buffers "y"
- mount the two rubber buffers "y" on the panel "C" (to rest the top "E")

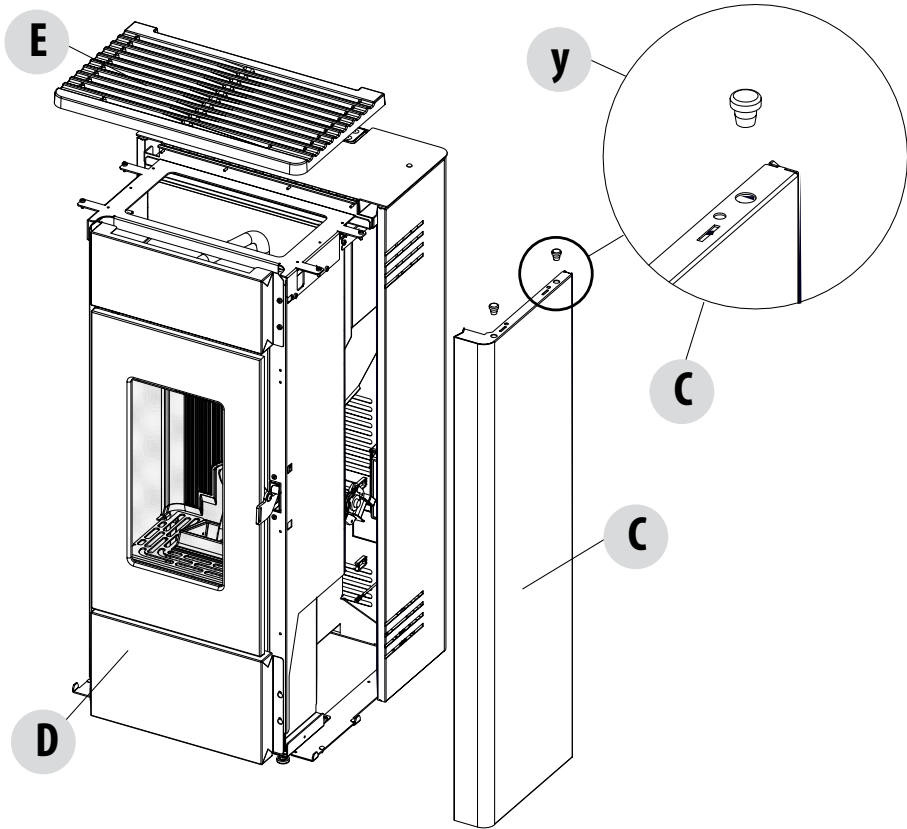

6-INSTALLATION AND ASSEMBLY

- Take metal side "C" and insert the holes "v" in the hooks "z" on the stove frame.

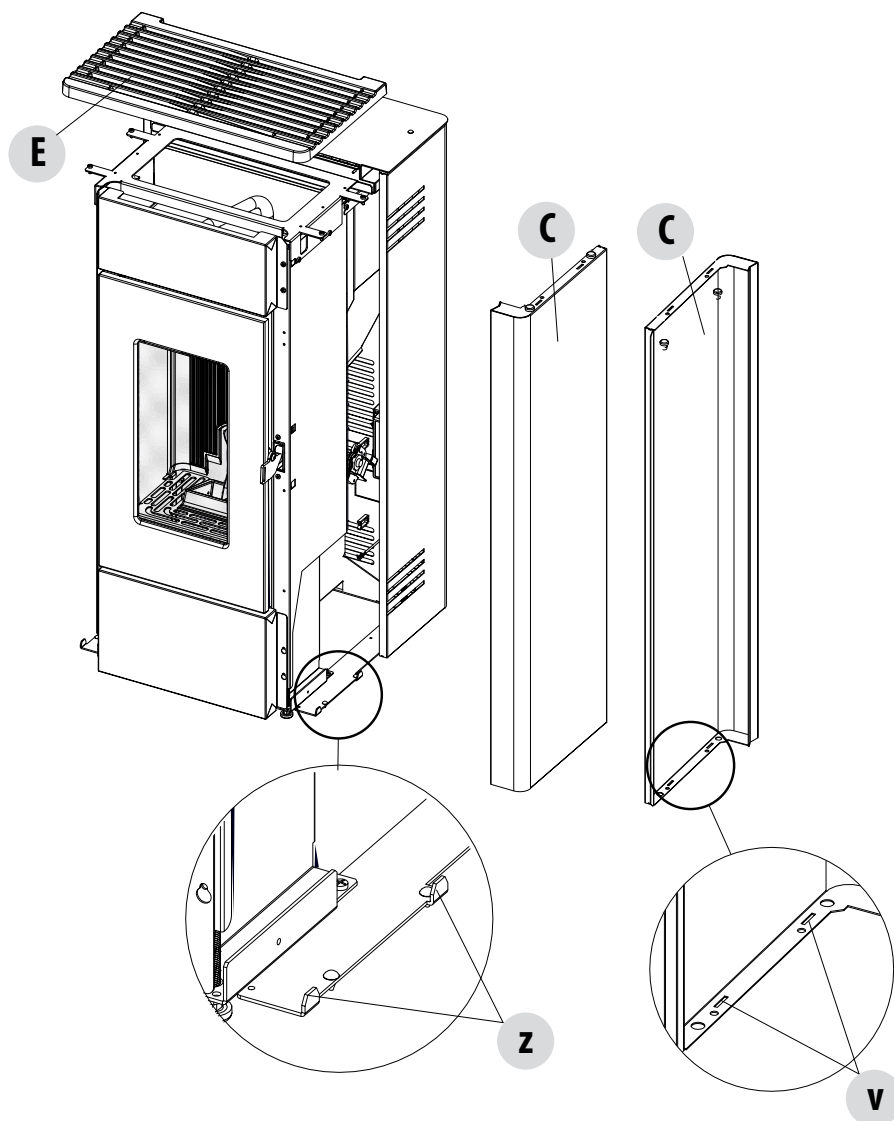

6-INSTALLATION AND ASSEMBLY

- fasten the panel "C" at the top with the two screws "X"

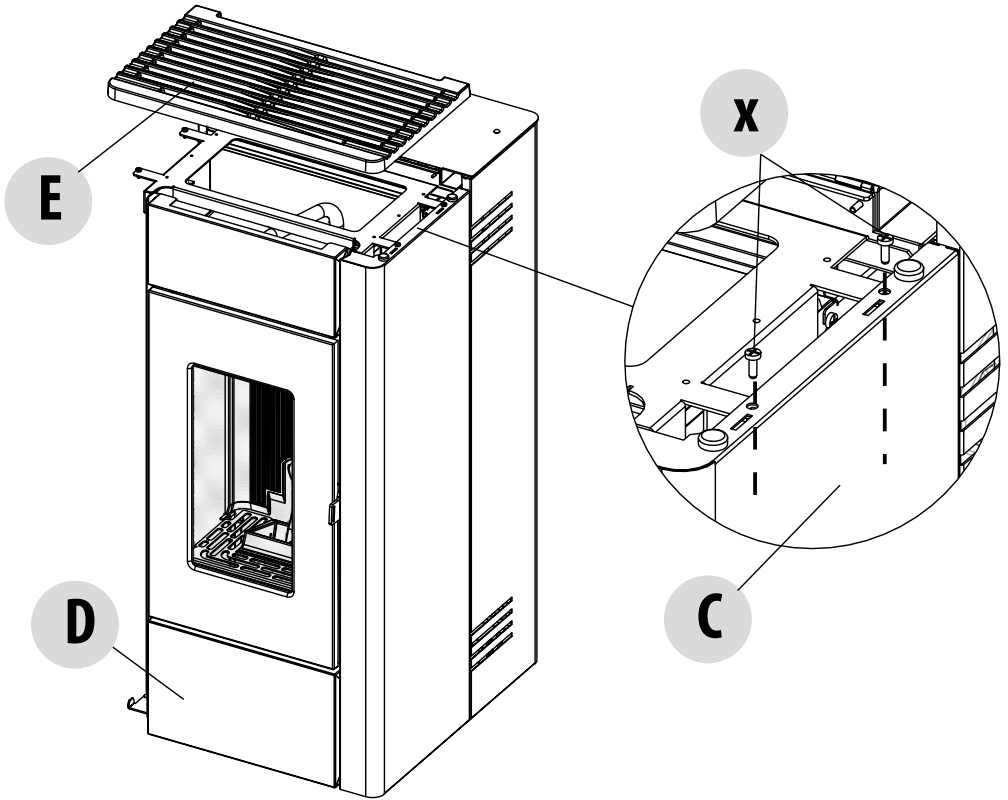

6-INSTALLATION AND ASSEMBLY

- repeat the same procedure with the other panel "C"
- refit the top "E" placing it on the rubber buffers "y"

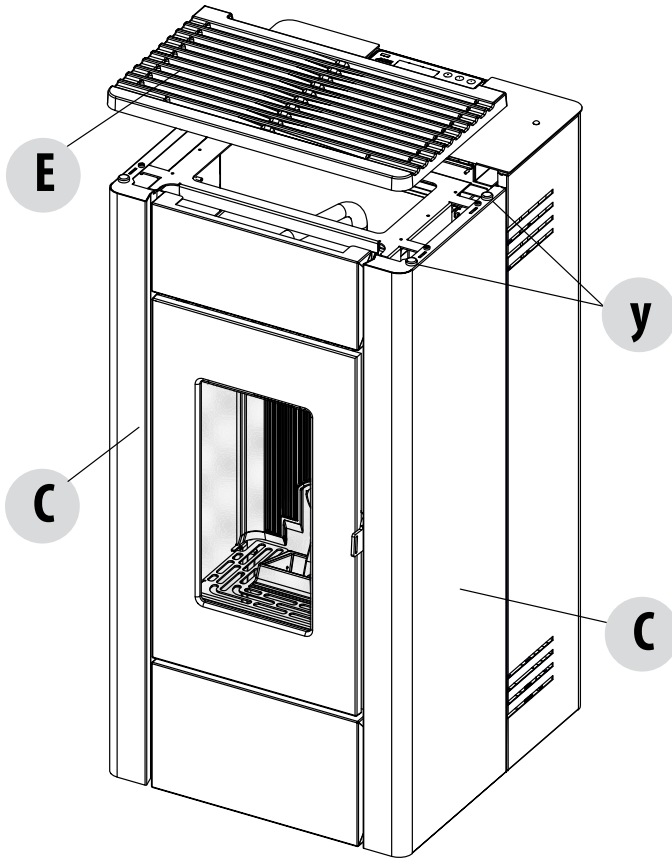

6-INSTALLATION AND ASSEMBLY

ACCESS TO THE ELECTRONIC BOARD

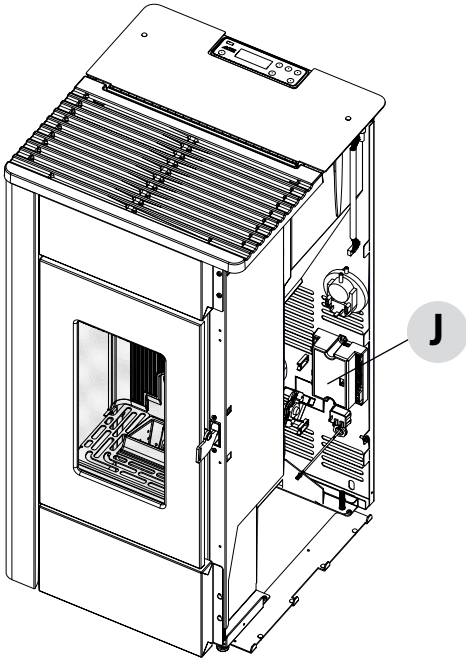

The circuit board "J" is on the right side (handle side). If you need to access the board, you must remove the back side panel as explained above.

ACCESS TO THE GEARMOTOR

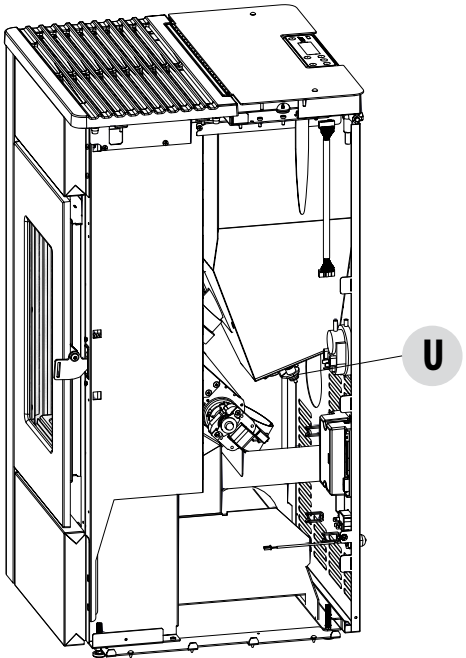

You must remove the side panel to access the gearmotor.

7-OPENING THE DOORS

OPENING THE DOOR OF THE FIREBOX

To open the firebox door, fit the cold handle "V" into its hole in the handle, and pull it outwards.



Attention!

*The firebox door must be closed properly for the stove to work correctly.
Only open the doors when the stove is switched off and cold.*

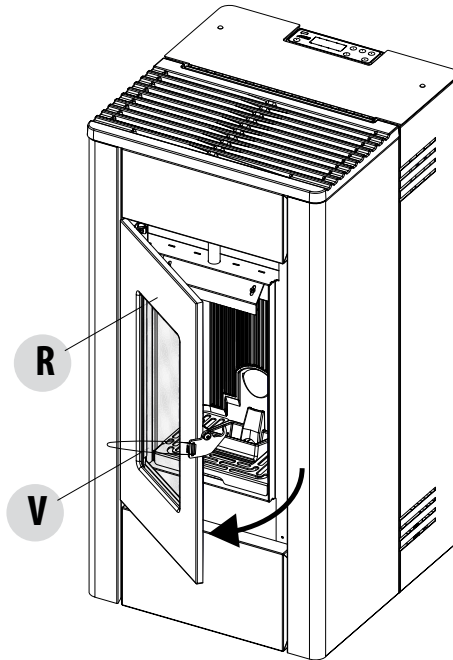

The handle "V" is located at the top below the cover of the pellet hopper on the right side of the stove (handle side).

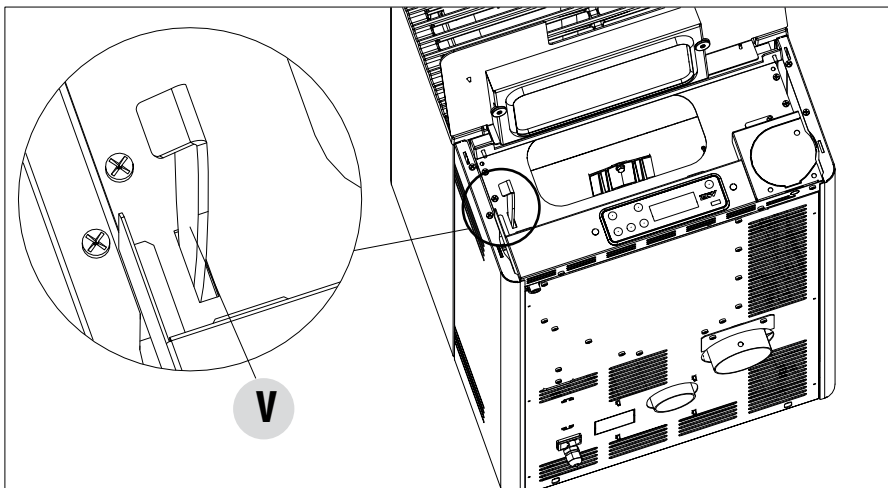

8-CONNECTION TO ADDITIONAL DEVICES

INSTALLATION OF WIFI PANEL (OPTIONAL-CODE 4020003)

Use the knockout hole at the back of the stove to install the Easy Connect WiFi panel and follow the installation instructions found inside the product. The WiFi panel must be connected to the board on the stove using the supplied cable. In order to use the WiFi system, download the Easy Connect app and follow the set-up instructions.

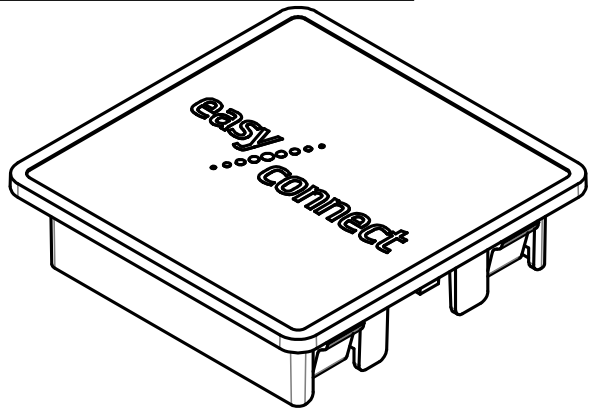
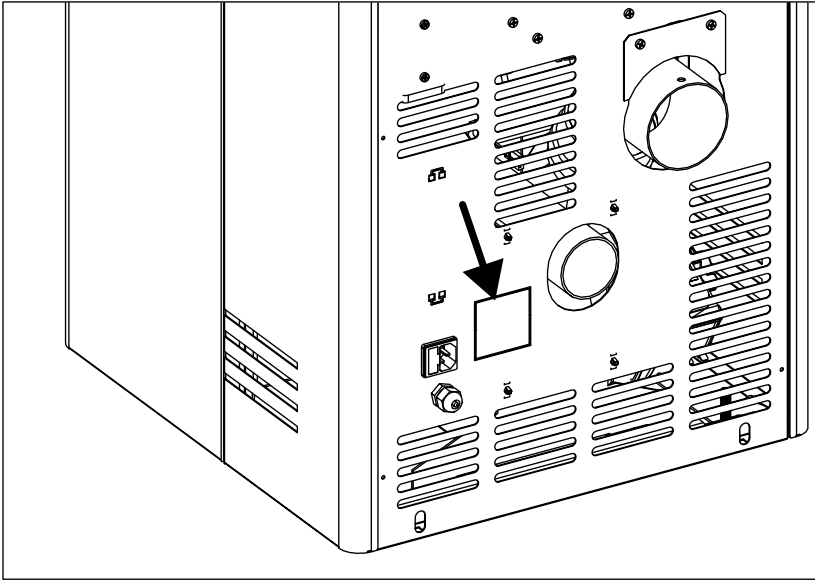

WIFI PANEL

9-LOADING THE PELLETS

LOADING THE PELLETS

The fuel is loaded from the top of the stove by lifting the hatch "A" or "B" (depending on the type of installation). Pour the pellets in slowly so that they are deposited at the bottom of the hopper.



If loading pellets when the stove is running, open the door of the tank using the stove mitten that comes with the stove itself.



When loading, do not let the pellet bag come into contact with hot surfaces.

Never remove the protection grid inside the hopper.

No other type of fuel other than pellets is to be inserted into the hopper, in compliance with above-mentioned specifications.

Store the spare fuel at an adequate safe distance.

Do not pour pellets directly onto the brazier but only into the hopper.

When the appliance is running and when it is turned off, most of the stove surfaces are very hot (door, handle, glass, smoke outlet pipes, etc.). Therefore it is recommended to avoid coming into contact with these parts.

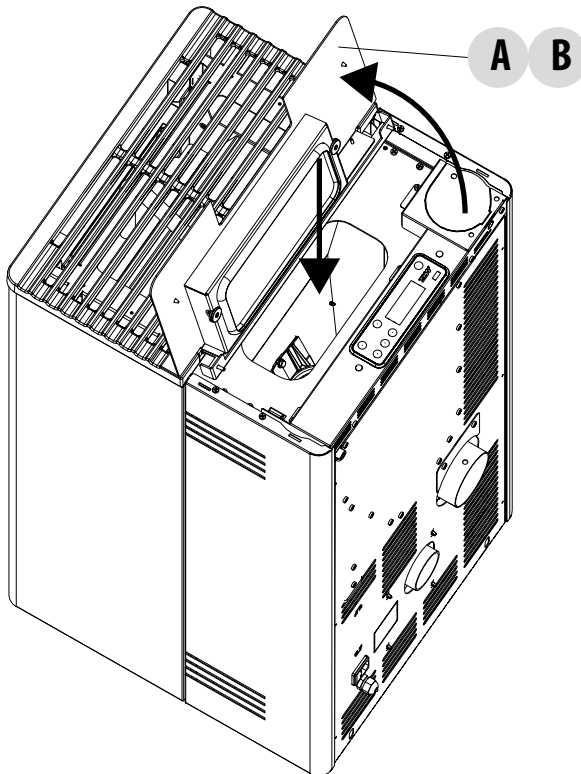

LOADING THE PELLETS

10-ELECTRICAL CONNECTION

ELECTRICAL CONNECTION

First connect the power cable to the back of the stove and then to a wall socket.



It is recommended to disconnect the power cable when the stove is not used.

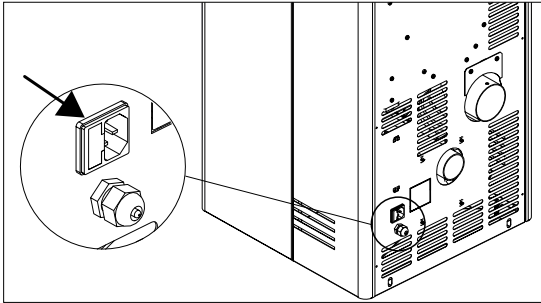

ELECTRICAL STOVE CONNECTION



The cable must never come into contact with the smoke exhaust pipe or any other part of the stove.

STOVE POWER SUPPLY

Connect the power cable to the back of the stove and then to a wall socket. The stove is then powered.

There is a fuse box also in the switch block next to the power socket. Open this compartment by simply lifting the cover, using a screwdriver as a lever from inside the power outlet compartment. Inside there are two fuses (5x20 mm T delayed / 3.15 A 250 V), which may need to be replaced if the stove is not powered (e.g. the control panel display does not light up) - operation to be implemented by an authorised

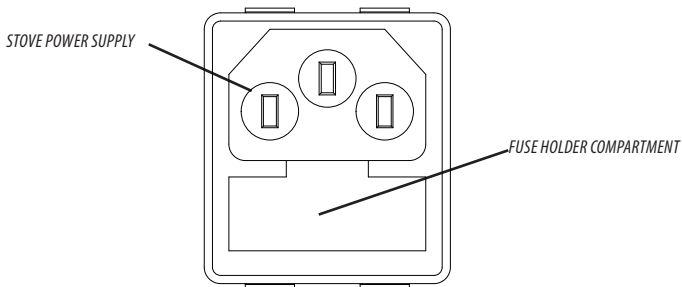

and skilled technician.



ATTENTION!

*All cleaning and / or replacement of parts must be carried out with the electric plug disconnected.
Disconnect the product from the 230V power supply before performing any maintenance operations.
If the cable is damaged, replace it.*

11-FIRST START-UP

WARNINGS BEFORE IGNITION

GENERAL WARNINGS

Remove any objects that may burn from the product brazier and from the glass (manual, various adhesive labels or any polystyrene).

Check that the brazier is positioned correctly and rests properly on the base.



The first ignition may not be successful as the feed screw is empty and does not always manage to load the brazier with the required amount of pellets in time to light the flame.



CANCEL THE FAILED IGNITION ALARM BY PRESSING AND HOLDING THE ON/OFF KEY FOR A FEW SECONDS. REMOVE THE PELLETS LEFT IN THE BRAZIER AND REPEAT IGNITION.

SETTINGS TO BE CARRIED OUT BEFORE THE INITIAL START-UP

First connect the power cable to the back of the stove and then to a wall socket.

To switch the stove on and off, press the button **1** on the control panel or press the button **3** from the remote control (optional accessory). The display on the panel will be ON with a flashing flame. When the flame stops blinking, the stove has reached the operating condition to "supply power".

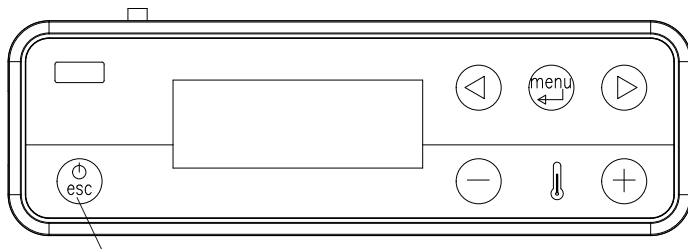
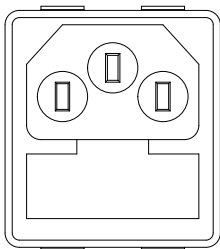

The default factory set room temperature is 20°C. To change this setting, follow the instructions in the adjustments menu. Do the same to set the heating water temperature and the speed of the room fan (if required). To activate an external thermostat, if present, see the dedicated paragraph.

SWITCHING THE EQUIPMENT OFF

To switch off the appliance, press the button 1 on the emergency panel or the button 3 on the optional remote control.

The equipment will start the shutdown process which involves consuming the residual pellets in the brazier, the latter being cleaned and the residual heat in the structure being dissipated.

During the residual heat dissipation phase, the fans operate at about 80% of their output and the speed cannot be varied. This is determined by the need for all the accumulated heat to be evacuated safely and quickly. The shutdown stage can last 15 - 30 minutes depending on the heat stored in the structure, determined by the duration and the operating speed of the product throughout the day.

When the internal temperature drops below the set thresholds, the fans for hot air and exhaust smoke extraction will automatically switch off.

11-FIRST START-UP

POWER SUPPLY

When ignition is complete, the panel will display ON with a steady flame at level 3 . The following flame modulation for higher or lower power is then controlled autonomously based on reaching the set temperature.

(also see "OPERATING MODE" - "Set Flame")

If the flame fails to ignite, despite a regular flow of pellets, check that the brazier is seated correctly: it must **rest snugly against the interlocking slot and be clean of any ash incrustations**. If no anomaly is found during this inspection, there may be a problem with the product components or installation may not be correct.



REMOVE THE PELLETS FROM THE BRAZIER AND CONTACT AN AUTHORISED TECHNICIAN.

Please ensure the brazier is clear of ALL pellets and ash build up following any failed ignitions. Failure to clear out the brazier prior to resetting may result in further failed ignitions or explosive ignition under certain conditions.



It is good practice to ensure effective ventilation in the room during the initial ignition, as the product will emit some smoke and smell of paint.

Do not stand close to the product and ventilate the room as mentioned. The smell of paint will disappear after about an hour of operation, however, it is not harmful in any case.

The product will be subject to expansion and contraction during the ignition and cooling stages, therefore slight creaking noises may be heard.

This is perfectly normal as the structure is made of laminated steel and must not be considered a defect.



DO NOT EXPECT HEATING EFFICIENCY IMMEDIATELY!!! THE PRODUCT NEEDS SOME RUNNING-IN TIME.

It is extremely important to make sure the product does not reach high temperatures straight away, but to increase the temperature gradually using low power at first.

This will prevent damage to the welds and to the steel structure.



Do not touch the product during the first lighting, as it is during this stage that the paint sets. If you touch the paint, you may expose the steel surface.

If required, touch up the paint with the spray can of the specific colour.

12-CONTROL PANEL

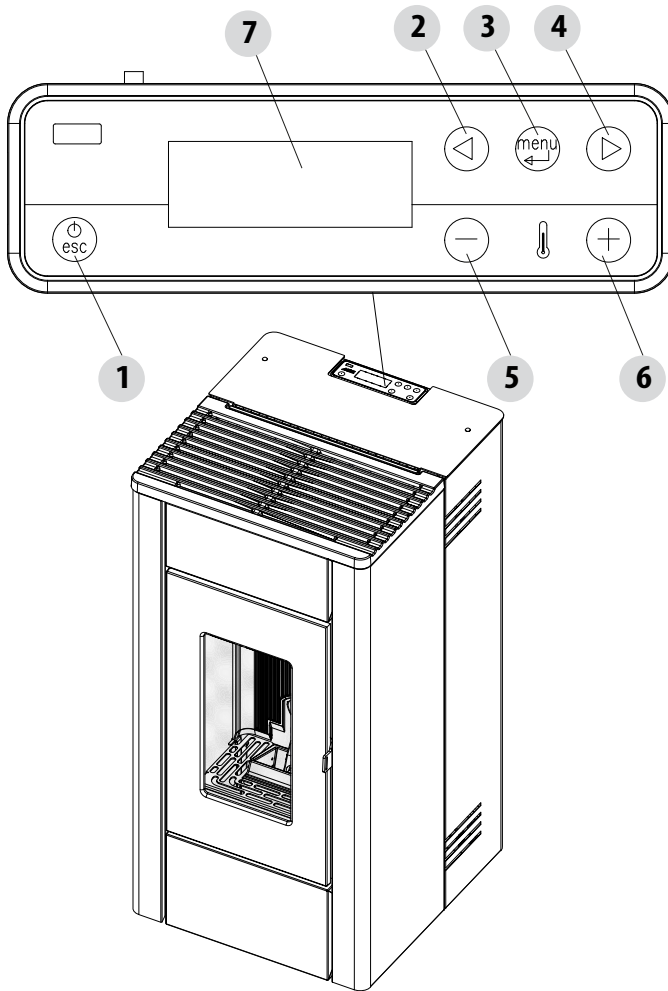

KEY

- | | |
|---|---|
| 1. Stove start-up/shutdown | 5. Decreases set temperature / programming functions. |
| 2. Scrolling down through the programming menu. | 6. Increases set temperature / programming functions. |
| 3. Menu | 7. Display. |
| 4. Scrolling up the programming menu. | |

13-MENU ENTRIES AND OPERATION

MAIN MENU

Press key 3 (menu) to access it. The options accessed are:

- Date and Time
- Timer
- Sleep (only when stove is on)
- Settings
- Info

Date and time configuration

Proceed as follows to configure the date and time:

- Press the “menu” key.
- Select “Date and Time”.
- Press “menu” to confirm
- Scroll through with the arrow keys and select the variables to be edited one at a time: Day, Hour, Min, Num. day, Month, Year.
- Press “menu” to confirm.
- Use the + and - keys to edit.
- Lastly, press “menu” to confirm and “esc” to exit.

CONFIGURATION OF PROGRAMMED MODE (TIMER) - Main menu



The current time and date must be configured to ensure correct operation of the timer.

There are six configurable TIMERS. For each one, the user can select a start-up and shutdown time and the days of the week when it is in use.

When one or more programs are active, the status of the stove and the TIMER “n” alternate on the display, “n” is the number of timer programs in use, separated by dashes

Example:

TIMER 1 Timer 1 program active.

TIMER 1-4 Timer 1 and 4 programs active.

TIMER 1-2-3-4-5-6 All timer programs active.

EXAMPLE OF PROGRAMMING

With the stove on or off:

- access the MENU,
- scroll to the TIMER item by using the <> arrows,
- press the “Menu” key
- the system shows “P1” (Press the <> keys to move through the timers P2, P3, P4, P5, P6)
- Press the “Menu” key to activate “P1”
- press + - and select “ON”
- press the “Menu” key to confirm

At this point the start time is 00:00. Press the + - key to set the start time and press the “menu” key to confirm.

Next, the proposed shutdown time is 10 minutes later than the configured start time: press the + key and edit the shutdown time, and press the “menu” key to confirm.

Next, you are asked to set the days of the week when the configured timer is to be enabled or disabled. Press the - or + keys to select the day you want to activate the time. It will light up white, then confirm with the “menu” key. If no day of the week is selected for enabling the timer, the timer program is no longer enabled on the status screen.

Next, program the other days or press “ESC” to exit. Repeat this procedure to program the other timers.

13-MENU ENTRIES AND OPERATION

EXAMPLES OF PROGRAMMING:

| P1 | | | P2 | | |
|----------------------------------|-------|-----|-------|-------|-----|
| on | off | day | on | off | day |
| 08:00 | 12:00 | mon | 11:00 | 14:00 | mon |
| Stove on between 08:00 and 14:00 | | | | | |

| P1 | | | P2 | | |
|----------------------------------|-------|-----|-------|-------|-----|
| on | off | day | on | off | day |
| 08:00 | 11:00 | mon | 11:00 | 14:00 | mon |
| Stove on between 08:00 and 14:00 | | | | | |

| P1 | | | P2 | | |
|--|-------|-----|-------|-------|-----|
| on | off | day | on | off | day |
| 17:00 | 24:00 | mon | 00:00 | 06:00 | tue |
| Stove on between 17:00 on Monday to 06:00 on Tuesday | | | | | |

NOTES ON USE OF THE TIMER

- The timer start always occurs with the last temperature and ventilation settings (or with the default settings at 20°C and V3 if they have never been altered).
- The start-up time goes from 00:00 to 23:50
- If the shutdown time has not yet been saved, the program proposes a start-up time at +10 minutes.
- A timer program turns off the stove at 24:00 on one day and another program starts it up at 00:00 on the next day: the stove remains on.
- A program proposes a start-up and/or shutdown time that overlap the times of another program: if the stove is already on, the start has no effect while OFF turns off the stove.
- When the stove is on and the timer is active, pressing the OFF key turns off the stove. The stove then restarts automatically at the next time of the timer.
- When the stove is off and the timer is active, pressing the ON key turns on the stove. The stove then stops automatically at the next time of the timer.

SLEEP FUNCTION (main menu)

Sleep mode may only be activated when the stove is on and allows you to quickly set a time for the product to turn off.

To set the Sleep function, proceed as follows:

- Enter the MENU
- Scroll to the SLEEP item with the <> arrows
- Press Menu
- Set the desired shutdown time by using the + and - keys.

The panel shows a shutdown time of 10 minutes after the current time, which can be adjusted with key 6 up to the following day (i.e. the shutdown can be delayed up to a maximum of 23 hours and 50 minutes).

If the SLEEP function is active with the TIMER active, the former has priority, therefore the stove will not turn off at the time set in the timer program but at the time set by the sleep function, even if it comes after the time set by the timer.

13-MENU ENTRIES AND OPERATION

OPERATING MODE ADJUSTMENT MENU

“Adjustments” menu settings determine the operating mode of the stove.

To access the menu, proceed as follows:

- Press the + - keys
- Scroll by using the <> arrows and select “Set Amb. T” or “Set Ventilation T” or “Set Flame”
- Press “menu” to enter the option selected.
- Change by using the + - keys.
- Press “menu” to confirm and “esc” to exit.

Set Amb T - this function is used to set the temperature to be reached in the room in which the stove is installed, from a minimum of 5°C to a maximum of 35°C. When this condition is met, the stove setting is equivalent to the minimum consumption values (the flame and hot air fan speed at minimum), and then returns to the set values when the room temperature drops below the set threshold.

N.B: The point to the right of the room temperature on the control panel display indicates the half degrees (e.g. 23.°C is equivalent to 23.5°C).

Set Vent - this function allows you to select the desired speed of the room fan from 1 to 5.

Set Flame - this function allows you to set the power of the flame from a minimum of 1 to a maximum of 5. The power levels correspond to a different value of fuel consumption, setting 5 heats the room in less time and setting 1 can keep the room temperature stable for a longer period of time. The set flame is automatically set to a minimum when the set temperature value is reached.

DISPLAY WITH STOVE ON

if the bars are all full, the stove is on flame power 5

if only one bar is full, the stove is on flame power 1

if the bars are flashing, automatic cleaning is in progress

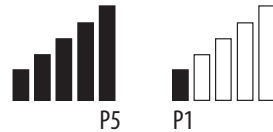

13-MENU ENTRIES AND OPERATION

SETTINGS MENU

The SETTINGS menu enables to configure the stove operating modes:

- a. Language.
- b. Cleaning (only displayed when stove is off).
- c. Feed screw loading (shown only when stove is off).
- d. Tones.
- e. External thermostat (activation).
- f. Auto Eco (activation).
- g. Eco Turn-off T (default 10 minutes).
- h. Pellet recipe.
- i. Smoke rpm % var.
- j. Components test (only displayed when the stove is off)
- k. "Chimney sweeper" function (can only be enabled when stove is on, to check emissions in field).
- l. Technical menu.

a - Language

Proceed as follows to select the language:

- Press the "menu" key.
- Use the arrow keys to scroll through and select "Settings"
- Press "menu" to confirm.
- Use the arrow keys to scroll through and select "language".
- Press "menu" to confirm.
- Use the + - keys to select the required language (IT/EN/DE/FR/ES/NL/PL/DK/SLO)
- Press "menu" to confirm and "esc" to exit.

b - Cleaning

Proceed as follows to select "Cleaning" (only with stove off):

- Press the "menu" key.
- Use the arrow keys to scroll through and select "Settings"
- Press "menu" to confirm.
- Use the arrow keys to scroll through and select "Cleaning".
- Press "menu" to confirm.
- Use the + - keys to select "On".
- Press "esc" to exit.

c - Feed screw loading

To select "Feed screw loading" (only with stove off), proceed as follows:

- Press the "menu" key.
- Use the arrow keys to scroll through and select "Settings"
- Press "menu" to confirm.
- Scroll with the arrows and select "Feed screw loading".
- Press "menu" to confirm.
- With the + key "Enable" feed screw loading.
- Press "esc" to exit.

13-MENU ENTRIES AND OPERATION

d - Tones

This function is disabled by default. To enable it proceed as follows:

- Press the “menu” key.
- Use the arrow keys to scroll through and select “Settings”
- Press “menu” to confirm.
- Use the arrow keys to scroll through and select “Tones”.
- Press “menu” to confirm.
- Using the + - keys, select “On/Off”.
- Press “menu” to confirm and “esc” to exit.

e - External thermostat (see dedicated chapter)

f - Auto-Eco activation (see dedicated chapter)

To select the Auto-Eco function, proceed as follows:

- Press the “menu” key.
- Use the arrow keys to scroll through and select “Settings”
- Press “menu” to confirm.
- Scroll by using the arrows and select “Auto-Eco”.
- Press “menu” to confirm.
- Use the + - keys to select “On”.
- Press “menu” to confirm and “esc” to exit.

g - Eco stop t (see dedicated chapter)

To select the Eco stop t function, proceed as follows:

- Press the “menu” key.
- Use the arrow keys to scroll through and select “Settings”
- Press “menu” to confirm.
- Scroll with the arrows and select “Eco stop t”.
- Press “menu” to confirm.
- With the + - keys, insert the minutes (from 1 to 30’).
- Press “menu” to confirm and “esc” to exit.

AUTO ECO MODE (see activation and shutdown paragraph above)

For activation of the “Auto Eco” mode and time adjustment, see paragraphs 8 f and 8 g respectively.

The option “ECO stop t” can be adjusted to ensure correct operation in the various environments in which the stove can be installed and to avoid constant shut-downs and start-ups when the room temperature is subject to sudden change (drafts, poorly insulated rooms, etc.). The ECO shutdown procedure is activated automatically when the power recall device is satisfied (room probe +1°C or external thermostat with an open contact), the “ECO stop t starts to decrease the time (factory default 5 minutes, which can be changed from the “Settings” menu). During this stage, the panel alternates between displaying ON with a small flame and Timer (if active) - Eco active. The minutes counting down to Eco Stop are shown at the top of the display. The flame moves to P1 and remains there until the set “ECO stop T” time reaches zero, and if the conditions are still met, goes to the shutdown stage. The ECO stop count is cancelled if one of the devices recalls power.

When the boiler begins to turn off, the panel displays: Off - Eco Active - flashing small flame.

When the stove turns off, OFF-ECO appears on the display with the flame symbol off.

The following conditions have to be met simultaneously for ECO to restart:

- room probe -1°C or external thermostat with a closed contact (for at least 20” in order to prevent false recalls)
- 5 minutes have passed since shutdown.

13-MENU ENTRIES AND OPERATION

h - Pellet Recipe

This function is for adapting the stove to the type of pellet in use. As there are many types of pellets available on the market, operation of the stove can vary considerably according to the quality of the fuel. When the pellets clog up the brazier due to excess loading of fuel or when the flame is always high even at low power, or when the flame is low, it is possible to decrease/increase the amount of pellets in the brazier:

The available values are:

- 3 = A decrease of 20% with respect to the factory setting.
- 2 = A decrease of 13% with respect to the factory setting.
- 1 = A decrease of 6% with respect to the factory setting.
- 0% No changes.
- 3 = An increase of 10% with respect to the factory setting.
- 2 = An increase of 6% with respect to the factory setting.
- 1 = An increase of 3% with respect to the factory setting.

Proceed as follows to edit the recipe:

- Press the "menu" key.
- Use the arrow keys to scroll through and select "Settings"
- Press "menu" to confirm.
- Scroll with the arrows and select "Pellet recipe".
- Press "menu" to confirm.
- Edit the % by using the + - keys.
- Press "menu" to confirm and "esc" to exit

i - Smoke rpm % variation

In the event the installation presents problems in extracting smoke (lack of draught or even pressure in the duct), it is possible to increase the smoke and ash extraction speed. This change resolves all potential problems related to pellets clogged in the brazier and deposits forming at the bottom of the brazier itself caused by poor quality fuel or fuel that produces a lot of ash. The values available range from -30% to +50%, with increments of 10 percent at a time. Negative variation may be required if the flame is too low.

To edit this parameter, proceed as follows:

- Press the "menu" key.
- Use the arrow keys to scroll through and select "Settings"
- Press "menu" to confirm.
- Scroll with the arrows and select "Fume rpm Var."
- Press "menu" to confirm.
- Edit the % by using the + - keys.
- Press "menu" to confirm and "esc" to exit

j - Components test

This can only be done when the stove is off and allows you to select the components to be tested:

- **Glow plug:** it is turned on for a fixed period of 1 minute during which the panel displays the countdown in seconds.
- **Feed screw:** it is powered for a fixed period of 1 minute during which the panel displays the countdown in seconds.
- **Extractor:** it is activated at 2500 rpm for a fixed period of 1 minute during which the panel displays the countdown in seconds.
- **Heat exchanger:** enables you to conduct the test in V5 for a fixed period of 1 minute during which the panel displays the countdown in seconds.

Proceed as follows to enable the "Components test" function (only with stove off):

- Press the "menu" key.
- Use the arrow keys to scroll through and select "Settings"

13-MENU ENTRIES AND OPERATION

- Press “menu” to confirm.
- Use the arrow keys to scroll through and select “Components test”.
- Press “menu” to confirm.
- Use the + - keys to select the test to be carried out
- Press “menu” to confirm and “esc” to exit

k - Chimney sweeper function (for maintenance operators only) -

This function can only be activated when the stove is on and power is supplied, and it forces heating operation at parameters P5, with fan (if present) in V5. Any corrections to the loading/smoke ventilation percentage must be read. This state lasts 20 minutes, the countdown is displayed on the panel.

The technician can stop this stage at any moment by quickly pressing the on/off key.

Enable the “Chimney sweeper” function as follows:

- Press the “menu” key.
- Use the arrow keys to scroll through and select “Settings”
- Press “menu” to confirm.
- Use the arrow keys to scroll through and select “Chimney sweeper function”.
- Press “menu” to confirm.
- Use the + - keys to select “On” (Off by default)
- Press “menu” to confirm and “esc” to exit

l - Technical menu

To access the technical menu, you must contact the service centre as it requires a password.

Proceed as follows to access the “technical menu”:

- Press the “menu” key.
- Use the arrow keys to scroll through and select “Settings”
- Press “menu” to confirm.
- Use the arrow keys to scroll through and select “Technical menu”.
- Press “menu” to confirm.
- With the + - keys, select “Product Type”, “Service”, “Counter memories”, “Parameters”.
- Press “menu” to confirm and “esc” to exit

INFO MENU

- Product type
- Firmware version
- Software info
- Total hours
- No. of start-ups
- Extractor rpm
- Smoke T.
- Heat exchanger voltage
- Feed screw loading
- Flame

13-MENU ENTRIES AND OPERATION

EXTERNAL THERMOSTAT CONNECTION (optional)



The room thermostat is not included with the stove and must be installed by a qualified technician.

ATTENTION!

The electrical wires must not come into contact with the hot parts of the stove.

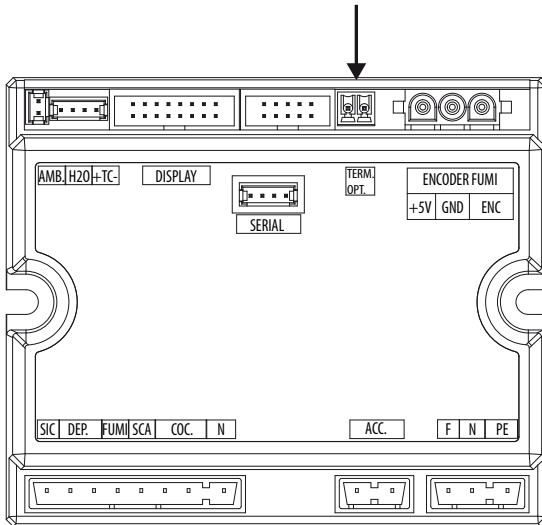

The temperature of the stove can also be controlled by an external room thermostat. It must be positioned centrally in the room where the stove is installed. It provides a closer match between the heating temperature required to the stove and the actual room temperature it provides.

Connect the cables coming from the external thermostat to terminal "Term opt" on board N100 on the stove.

Proceed as follows to enable the external thermostat (factory settings OFF):

- Press the "menu" key.
- Scroll with the arrows to "Settings".
- Press "menu" to select.
- Now use the arrows to scroll to "External thermostat".
- Press "menu" to select.
- Press the - + keys.
- Select "On" to activate the external thermostat.
- Press the "menu" key to confirm.
- Press the "esc" key to exit.

Once the external thermostat has been enabled, instead of displaying the detected temperature from the probe on the stove, ON or OFF will appear, depending on whether you have requested heat from the external thermostat or not

ON if the external thermostat contact is closed, **OFF** if the contact is open.

14-SAFETY DEVICES

SAFETY DEVICES

The product is fitted with the following safety devices

PRESSURE SWITCH

Monitors pressure in the smoke duct. It is designed to shut down the pellet feed screw in the event of an obstructed flue or significant back-pressure (from wind)

SMOKE TEMPERATURE PROBE

Detects the temperature of the smoke, thereby enabling start-up or stopping the product when the temperature drops below the preset value.

CONTACT THERMOSTAT IN THE FUEL TANK

If the temperature exceeds the preset safety level, it immediately shuts down the stove.

ELECTRICAL SAFETY

The stove is protected against violent changes in current by a general fuse located in the control panel at the back of the stove. Other fuses that protect the circuit boards are located on the latter.

SMOKE FAN

If the fan stops, the circuit board immediately shuts off the supply of pellets and an alarm message is displayed.

GEAR MOTOR

If the gear motor stops, the stove will continue to run until the flame goes out due to lack of fuel and until a minimum level of cooling is reached.

TEMPORARY POWER OUTAGE

When a power outage lasts less than 10" the stove returns to its previous operating state. If it is longer, it executes a cooling/re-ignition cycle.

FAILED IGNITION

If during ignition no flame develops, the stove will go into alarm condition.



TAMPERING WITH THE SAFETY DEVICES IS PROHIBITED



If the product is NOT used as described in this instruction manual, the manufacturer declines all liability for any damage caused to persons and property. The manufacturer furthermore denies any liability for damage to persons and property arising from failure to observe all the rules contained in the manual and specifically:

- *All the necessary measures and/or precautions must be adopted when performing maintenance, cleaning and repairs.*
- *Do not tamper with the safety devices.*
- *Do not remove the safety devices.*
- *Connect the product to an efficient smoke expulsion system.*
- *First, check that the environment where it is to be installed is properly ventilated.*

Only after having removed the cause that triggered the safety system is it possible to start the product again and therefore restore automatic operation of the probe. This manual will help you understand which anomaly has occurred, and explain how to operate according to the alarm message displayed on the appliance.

15-ALARMS

ALARM SIGNALLING

When an operating condition other than the one expected for regular stove operation occurs, an alarm is triggered.

The reason for the alarm is shown on the control panel. The sound signal is not enabled for alarms A01-A02 in order not to disturb the user when there is an absence of pellets in the hopper during the night.

| Panel signalling | Type of problem | Solution |
|------------------------------------|---|---|
| A01 | The flame does not ignite | Check the level of pellets in the hopper. Check that the brazier is correctly positioned in its seat and has no deposits or unburnt material. Make sure the glow plug warms up. Thoroughly empty and clean the brazier before restarting. |
| A02 | The fire goes out abnormally. | Check the level of pellets in the hopper. |
| A03 Thermostat alarm | The temperature of the pellet hopper exceeds the required safety threshold. | Wait until the end of the cooling stage, stop the alarm and re-ignite the stove setting the supply of fuel to minimum (SETTINGS menu - Pellet recipe). If the alarm persists, contact the service centre. Check whether the room fan is working correctly. |
| A04 | Smoke overtemperature. | Reduce the load of pellets (SETTINGS menu - Pellet recipe). Check cleaning of the brazier |
| A05 Safety devices alarm | Smoke pressure switch triggered | Check for chimney obstructions / door open |
| | Fuel loading hatch | Close the hatch. Lower the fuel level in the hopper. |
| | Open stove door | Close the door |
| A08 | Anomalous operation of smoke fan. | Cancel the alarm and turn the stove on again. If the alarm persists, contact the service centre. |
| A09 | Smoke sensor fault. | Cancel the alarm and turn the stove on again. If the alarm persists, contact the service centre. |
| Service | Routine maintenance warning (does not stop operation). | When this blinking message appears at start-up, it means that the operating hours preset before maintenance have expired. Call the service centre. |

ALARM RESET

To reset the alarm, press and hold key 1 (ESC) for a few seconds. The stove checks whether or not the cause of the alarm is ongoing.

In the first case, the alarm continues to be displayed, in the second case it turns OFF.

If the alarm persists, contact a service centre.

NORMAL SHUTDOWN (on the panel: OFF with flashing flame)

When the shutdown key is pressed, or when there is an alarm signal, the stove enters the thermal extinguishing stage which involves automatic execution of the following stages:

- Pellet loading stop
- The room fan maintains the set speed until reaching the shutdown temperature
- The smoke extractor fan is activated at maximum speed and remains on for a fixed period of 10 minutes, at the end of which if the

15-ALARMS

smoke T has dropped below the shutdown threshold, the fan stops, otherwise it will continue to operate at minimum speed until the temperature drops below the threshold and then turn off.

- If the stove has been shut down regularly but, due to thermal inertia, the smoke temperature exceeds the threshold again, the shutdown stage will be repeated at minimum speed until the temperature drops.

BLACKOUT WITH STOVE ON

In the event of a blackout, the stove acts as follows:

- Blackout less than 10'': resumes operation;
- After a power outage of more than 10'' which occurred when the stove was on, or during ignition, when the stove is powered again it returns to its previous operating condition as follows:
 1. Cools the boiler by activating the smoke extractor at minimum speed for 10' then proceeds to the next step;
 2. Restores the stove to the operating condition prior to the blackout.

During stage 1, the panel shows ON BLACK OUT.

During stage 2, the panel shows Ignition.

If during stage 1 the stove receives manual user commands from the control panel, it stops the blackout reset sequence and begins the start-up or shutdown as requested by the user.

BLACKOUT OF MORE THAN 10'' DURING STOVE SHUTDOWN

If the stove experiences a loss of power LONGER THAN 10'' while it is shutting down, when power is restored to the stove, it will automatically turn on in shutdown mode, even if the smoke temperature has fallen below 45°C in the meantime. This last stage can be skipped by pressing key 1 (esc) (skips to start-up) and pressing it again (recognises that the stove is off).

BLACKOUT OF MORE THAN 10'' WITH THE STOVE OFF FOR ECOSTOP

Once power has been restored, a 5-minute timer is set as though the stove were in shutdown mode. Should there be a request for heat in these 5 minutes, the stove will not start.

SAFETY DEVICES ALARM A05

The safety devices alarm includes operation of the smoke pressure switch, of the fuel loading hatch and of the open stove door. The alarm will be triggered after 30 seconds, after which the stove will stop working (e.g. after 30 seconds with the pellet loading hatch open, alarm A05 will be triggered).

15-ALARMS

ALARM A05 AND MINIMUM NEGATIVE PRESSURE INSIDE THE PELLET HOPPERS OF THE SEALED PRODUCTS

In the event that alarm A05 is triggered often, please note that:

| | | |
|---|---------------------------------|---|
| A05 Safety devices alarm | Smoke pressure switch triggered | Check for chimney obstructions / door open |
| | Fuel loading hatch | Close the hatch. Lower the fuel level in the hopper. |
| | Open stove door | Close the door |

it is required to check some points to verify the cause of the problem and potentially operate on some adjustments and/or safety devices to restore correct operation of the product.

However please note that all adjustments and alterations affecting the operational safety devices, must only be performed if THE PRODUCT IS INSTALLED IN COMPLIANCE WITH THE STANDARDS AND LAWS IN FORCE AND IF IT IS SERVICED PROPERLY BY AUTHORISED AND SPECIALISED PERSONNEL. Alterations performed randomly, to ensure operation of the product even under non-compliant conditions, can cause serious damage to property and injuries to people.



Attention!

The adjustments must only be carried out by authorised and qualified personnel under their responsibility and by checking the conformity of the installation beforehand. The manufacturer declines all liability for damage to property or injuries to people if the safety devices are altered.

All liability for improper use of the product is entirely borne by the user and relieves the manufacturer from any civil and criminal liability.

Series of stoves equipped with a pressure switch installed on the hopper with the sampling point positioned on the bottom, to the right of the gear motor. This system protects the whole system ensuring tightness of the stove throughout its duration.

It is important to understand that the pressure switch can be triggered with each significant drop in negative pressure and may be due to:

- Flue clogging.
- The presence of a foreign body in the flue (birds, nests, clogged grilles, etc.).
- Wind coming through the flue because it is unprotected or the installation was wall-mounted or required no flue.
- Cold air draught down the flue.
- A damaged pressure switch.
- Blocked membrane inside the pressure switch because soot or pellet dust got in.
- The pellet hopper is open or ajar for more than 60 seconds (60 seconds is the estimated time to reload the hopper).
- Pellets trapped between the hopper cover and the hopper, which prevents the gasket from sealing.
- Broken/worn hopper cover gasket.
- The gasket between the feed screw and the boiler is damaged or positioned incorrectly.
- Fire door is open or the gasket is worn.
- Clogged lateral smoke exchangers.
- Inspection caps with gaskets installed incorrectly after maintenance.
- Feed screw clogged by compressed pellets at the top.
- The installation is compliant and the flue/smoke fitting does not generate obvious obstructions which can stop the release of smoke, such as: long horizontal sections (over 3 metres), uninsulated smoke ducts, "wall-mounted" smoke exhaust without proper terminals (installation regulated and permitted in France only [ZONE 3])
- Internal air extraction or recirculation systems (e.g. VMC systems) that generate internal negative pressure exceeding the value required by law (not exceeding 4 Pa)
- Installed without combustion air ducting, it is crucial to check that there is an efficient air inlet dedicated to the stove, according to the specifications referred to in chapter 2 of this manual.

The circuit board has also been equipped with an automatic device with a timer and contactors which increase the RPM of the smoke extractor so as to restore the negative pressure inside the hopper and therefore the pressure switch, if the cover is opened for top-up or if there is an immediate or occasional pressure drop such as gusts of wind outside. If the pressure drop lasts for more than 60 seconds, the product goes into alarm status (A05 or A18)

15-ALARMS

Remembering that the draught recommended for the products to work properly is 10 Pa at maximum capacity and 5 Pa at minimum (according to the technical data sheet found in the user and maintenance manual), adjustments may be required in worse draught conditions (also due to the position of the flue in areas that are particularly subject to adverse weather such as prevailing winds, snow, northern exposure, etc.) so as to always guarantee the required negative pressure inside the hopper.

To compensate for the lack of internal negative pressure simply adjust the speed (RPM) of the smoke extractor so as to guarantee the minimum values of the table.

If the negative internal pressure values are noted to be lower than those indicated, this can also be due to the internal gaskets not being sealed properly or to the product being worn over time.

OPERATING INSTRUCTIONS ON NEGATIVE PRESSURE INSPECTIONS AND POSSIBLE VARIATIONS OF THE RPM

Connect a pressure gauge to the pressure outlet on the hopper:

- For products with a specific pressure outlet in the hopper, access the sampling point and connect the pressure gauge
- For products without a dedicated pressure outlet, disconnect the tube of the pressure switch from the pressure outlet on the hopper, add a "Tee" on the tube to intercept the circuit connecting the pressure gauge and reconnect the tube to the pressure outlet on the hopper.

Possible adjustments of combustion and consequently of the negative pressure inside the hopper can be implemented in two ways:

A) Changing the RPM value of the smoke extractor in the SETTINGS MENU

- The available values are from -3 to +3 which, as a percentage, correspond to:
- RPM: -10% +10% in Active System products
- RPM: -30% +50% in NON-Active System products
- The percentage variation affects all power values (1 to 5) proportionally and as a percentage. The percentage variation does not affect intermediate operating stages such as SWITCH ON, FIRE ON or SWITCH OFF
- As the RPM increases, suction also increases and consequently the internal negative pressure, thereby compensating the phenomena that trigger the alarm.

B) Adjusting the RPM of the gear motor manually in the TECHNICAL PARAMETERS MENU

- The pressure switch has a calibration of 10/20 Pa which means that it trips when the negative pressure inside the hopper drops below 10 Pa and requires more than 20 Pa negative pressure inside the hopper for it to reset
- The negative pressure value at the minimum power must always be higher than 10 Pa while also maintaining a reasonable margin that can worsen over time due to the gaskets or similar being worn (at least 12/13 Pa)
- The negative pressure at maximum power must always be above 20 so that the pressure switch can reset when the pressure switch resetting automated device is activated. The pressure switch resetting procedure (such as after opening the cover to top-up the hopper), requires the electronics to push the RPM of the smoke extraction fan up to POWER 5 (P5) for a few moments. At P5, therefore, the negative pressure inside the hopper must always be > 20 Pa (recommended 22/23 Pa to preserve the margin).
- **N.B. = The TECHNICAL PARAMETERS menus are password-protected to prevent the user from accessing them inadvertently**



Attention! The factory setting on the product is designed to obtain the certified technical data. With a data discrepancy (such as the pellet recipe), the settings may be modified as explained above.

The adjustments must only be carried out by authorised and qualified personnel under their responsibility and by checking the conformity of the installation beforehand.

15-ALARMS

NEGATIVE PRESSURE INSIDE THE HOPPER WITH FACTORY-SET PARAMETERS AND A DRAUGHT OF 5 Pa (MINIMUM RECOMMENDED)

| POWER | P1 | P2 | P3 | P4 | P5 | VALUES |
|-------|--------------|--------------|--------------|--------------|--------------|-------------------|
| 6 kW | 13.7/14.2 Pa | 15.1/15.6 Pa | 17.1/17.5 Pa | 19.1/19.5 Pa | 22.0/22.2 Pa | Draught |
| | 95°C | 110°C | 125°C | 141°C | 165°C | Smoke temperature |
| 8 kW | 13.8/14.3 Pa | 15.6/16.1 Pa | 17.8/18.0 Pa | 21.7/22.2 Pa | 26.1/26.6 Pa | Draught |
| | 104°C | 119°C | 145°C | 148°C | 184°C | Smoke temperature |
| 10 kW | 15.9/16.3 Pa | 20.4/20.9 Pa | 25.8/26.3 Pa | 31.8/32.3 Pa | 36.5/37.0 Pa | Draught |
| | 108°C | °C | 150°C | °C | 230°C | Smoke temperature |
| 12 kW | 16.5/17.3 Pa | 20.4/20.9 Pa | 25.8/26.3 Pa | 31.8/32.3 Pa | 36.5/37.1 Pa | Draught |
| | 118°C | 127°C | 155°C | 172°C | 195°C | Smoke temperature |
| 14 kW | 17.6/18.0 Pa | 19.8/20.4 Pa | 23.1/23.7 Pa | 28.9/29.6 Pa | 37.8/38.2 Pa | Draught |
| | 118°C | 131°C | 161°C | 187°C | 210°C | Smoke temperature |

PLEASE NOTE The indicated negative pressure readings may differ by ± 1 Pa based on flue gas temperature. Likewise, flue gas temperature may differ by ± 10 °C based on fuel quality or appliance cleanliness.

16-RECOMMENDATIONS FOR SAFE USE



ONLY CORRECT INSTALLATION AND APPROPRIATE MAINTENANCE AND CLEANING OF THE APPLIANCE CAN GUARANTEE CORRECT OPERATION AND SAFE USE OF THE PRODUCT.

We would like to inform you that we are aware of cases of malfunctioning of domestic pellet-fuelled heating products, mainly due to incorrect installation and use, as well as inadequate maintenance.

We would like to assure you that all of our products are extremely safe and certified according to European standards of reference. The ignition system has been tested with the utmost attention to enhance ignition efficiency and to prevent any type of problem, even in the worst operating conditions. In any case, as with any other pellet-fuelled product, our appliances must be installed correctly and undergo regular periodical cleaning and maintenance to guarantee safe operation. Our studies show us that malfunctioning is mainly due to the combination of part or all of the following factors:

- Brazier holes obstructed or brazier deformed, due to lack of maintenance and conditions which can cause delayed ignition, generating an anomalous production of unburnt gases.
- Insufficient combustion air due to a reduced or clogged air inlet duct.
- Use of smoke ducts nonconforming to regulatory installation requirements, failing to guarantee an adequate draught.
- Partially clogged chimney, due to lack of maintenance, reducing the draught and making ignition difficult.
- End chimneypot not conforming to the indications of the instruction manual, and therefore not suitable to prevent potential inverse draught.
- This factor is crucial when the product is installed in especially windy areas, such as coastal regions.

The combination of one or more of these factors may generate severe malfunctioning conditions.

To keep this from occurring, it is crucial to guarantee that the product is installed in compliance with standards in force.

Furthermore it is of the utmost importance to comply with the following simple rules:

- Every time the brazier is removed for cleaning, it must always be put back properly in the work position before using the product, completely removing any residual dirt left on the support base
- Pellets must never be loaded in the brazier manually, neither before ignition or during operation.
- The build-up of unburnt pellets following failed ignition must be removed before repeating ignition. Also check that the combustion air inlet/smoke outlet is fitted correctly in place and working properly.
- If ignition fails repeatedly, immediately suspend use of the product and contact a qualified technician to check its operation.

Compliance with these indications is absolutely sufficient to ensure proper operation and to avoid any type of problems with the product.

If the aforementioned precautions are not taken, and during ignition the brazier is overloaded with pellets thus generating anomalous smoke in the combustion chamber, carefully follow the indications below:

- Do not disconnect the electrical power to the product for any reason whatsoever: this would stop the smoke extractor, releasing smoke into the room.
- Take the precaution of opening the windows to ventilate the installation room from any smoke (the chimney might not be working properly)
- Do not open the fire door: this would compromise regular operation of the smoke extraction system to the chimney.
- Simply switch the stove off by operating on the on-off button on the control panel (not the rear power supply socket button!) and move away until the smoke has been completely extracted.
- Before attempting re-ignition, clean the brazier and its air passage holes completely of all deposits and unburnt pellets. Put the brazier back in place, removing any residue from its support base. If ignition fails repeatedly, immediately suspend use of the product and contact a qualified technician to check its operation and the chimney.

17-CLEANING

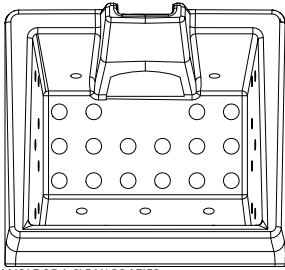

EXAMPLE OF A CLEAN BRAZIER



EXAMPLE OF A DIRTY BRAZIER

Only by properly servicing and cleaning the product is it possible to ensure its safety and correct operation.



ATTENTION!

All the cleaning operations of all parts must be performed with the product completely cold and unplugged. Disconnect the product from the 230V power supply before performing any maintenance operation

The product requires little maintenance if used with certified good quality pellets.

DAILY OR WEEKLY CLEANING PERFORMED BY THE USER

Brazier cleaning

Before ignition, always clean the brazier "b" and remove any ash or incrustation from it that might obstruct the air flow holes, paying attention to hot ash. In the case of ignition failure, or if fuel in the hopper runs out, unburned pellets may accumulate in the brazier. Always empty the residue in the brazier before each start-up. **Only if ash is completely cold** may a vacuum cleaner be used to remove it. In this case, use a suitable vacuum cleaner to remove small sized particles.



REMEMBER THAT ONLY A CORRECTLY POSITIONED AND CLEAN BRAZIER CAN GUARANTEE IGNITION AND OPTIMAL OPERATION OF YOUR PELLET PRODUCT. IN CASE OF FAILED IGNITION AND AFTER ANY OTHER BLOCKED STATE OF THE PRODUCT, IT IS ESSENTIAL TO EMPTY THE BRAZIER BEFORE EVERY RESTART.

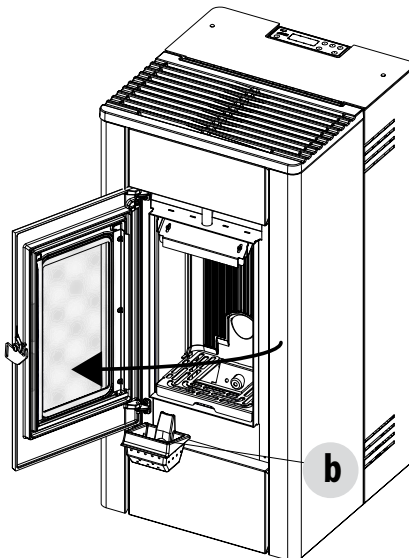

17-CLEANING

For the brazier to be cleaned properly, remove it from its housing completely and thoroughly clean all the holes and the grate on the bottom. If high quality pellets are used, you will normally only need to use a brush to restore the optimal operating conditions of the component.

Cleaning the ash collection compartment

In order to clean the ash compartment, remove the grid "g" by simply lifting it from its seat. Wipe away any residual ash and reposition the grid "g". The quality of the pellets used and user experience will determine the required cleaning frequency. **However, it is recommended not to exceed 2 or 3 days.**

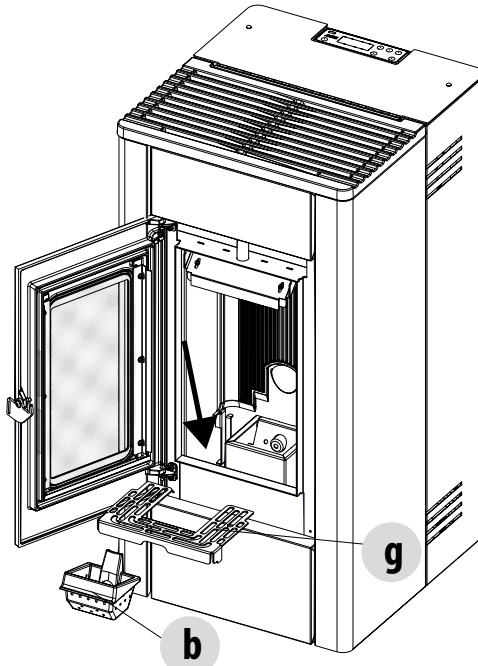

CLEANING THE GLASS

It is recommended to clean the ceramic glass with a dry brush, or if it is very dirty, spray with a little specific detergent and clean with a cloth.



ATTENTION!

Do not use abrasive products and do not spray the glass cleaning product on the painted parts and on the door gaskets (ceramic fibre cord).

17-CLEANING

PERIODIC CLEANING PERFORMED BY A QUALIFIED TECHNICIAN

CLEANING THE HEAT EXCHANGER

Half-way through the winter season, **but especially at the end**, the compartment through which the exhaust smoke passes will need to be cleaned.

This cleaning process is mandatory in order to facilitate the general removal of all combustion residue, before it becomes very difficult to remove it due to moisture compacting it over time.



ATTENTION:

It is obligatory to have an authorised and skilled technician perform the periodic end-of-season cleaning in order to replace any worn gaskets.

CLEANING THE LOWER COMPARTMENT

To clean the lower ash compartment, you must remove the top "E", the side panels "C" and the front panel "D" (see instructions in specific chapters). Now remove the four screws "v", remove the plate "n" and the gasket "o". Use the nozzle of a vacuum cleaner to remove any ash and soot that may have built up in the lower exchanger (smoke extractor) indicated by the arrow.

Before putting the cap "n" back, it is recommended to change the gasket "o".

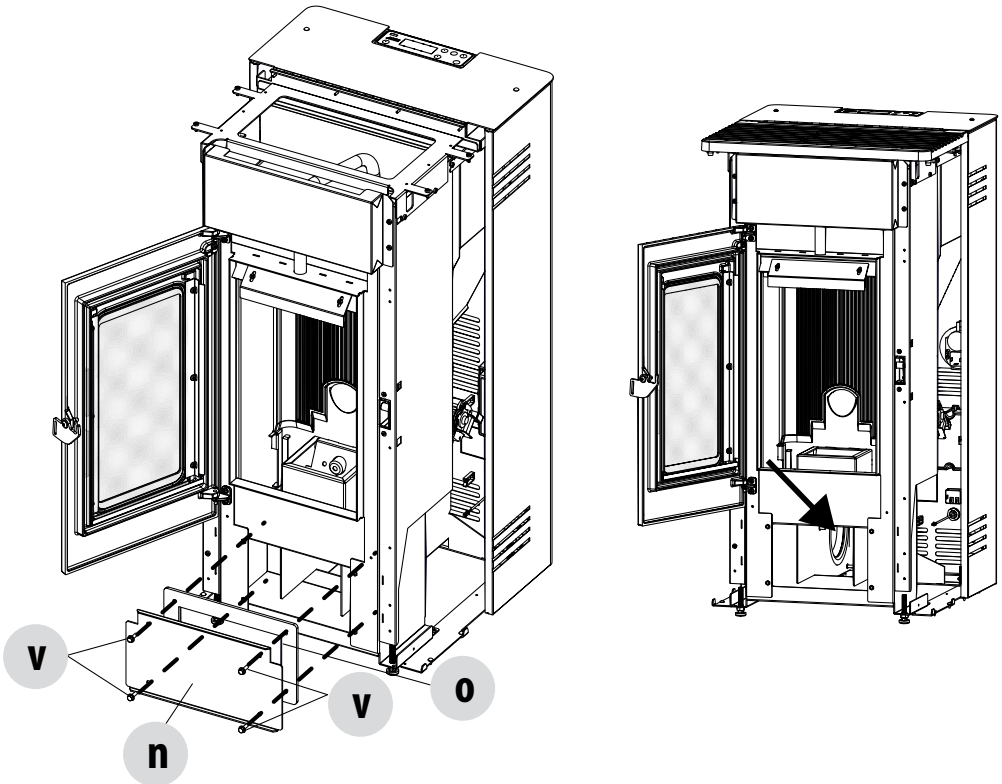

17-CLEANING

CLEANING THE EXCHANGER

CLEANING THE UPPER COMPARTMENT

Clean the upper exchanger when the stove is cold and without cladding. After removing the cap to clean the lower compartment "n" (see previous paragraph), use a stiff rod or a bottle brush to scrape the walls of the firebox (see arrow) to make the ash fall into the lower compartment.

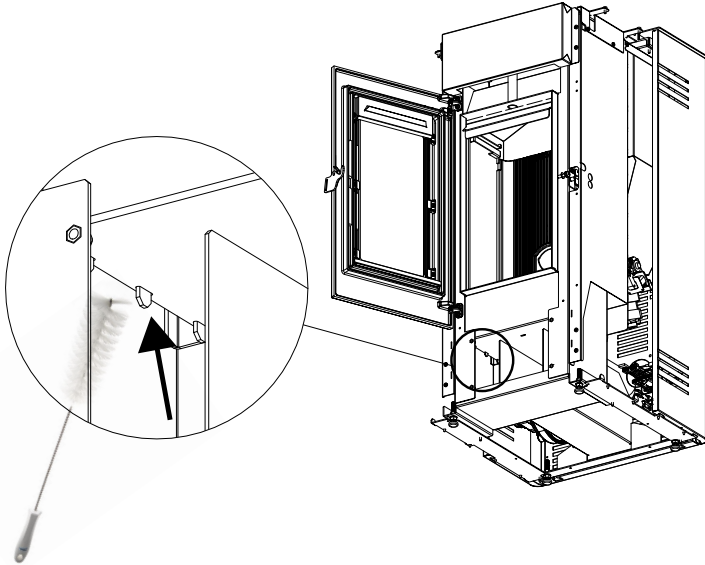

Then remove the upper calorite plate "H", to do this open the firebox door, hold the top of the calorite plate "H" and lift it upwards, tilt it to the right or to the left in order to release it from the supports and remove it.

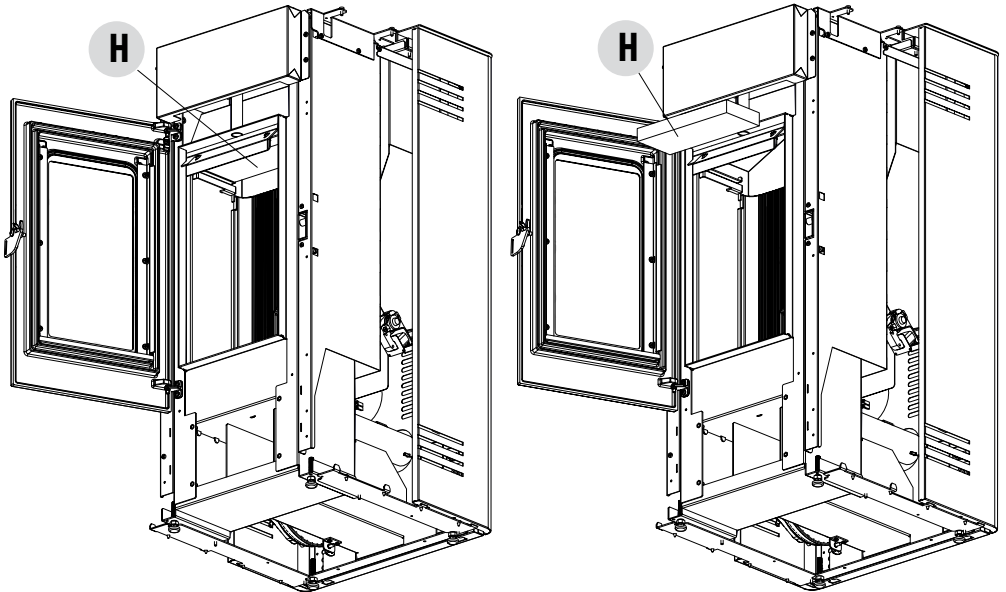

17-CLEANING

Use a stiff rod or a bottle brush to scrape the walls of the firebox (see arrow - respectively to the right and to the left of the firebox) to make the ash fall into the lower compartment. Then thoroughly clean the lower exchanger, replace any gaskets if needed, and reassemble.

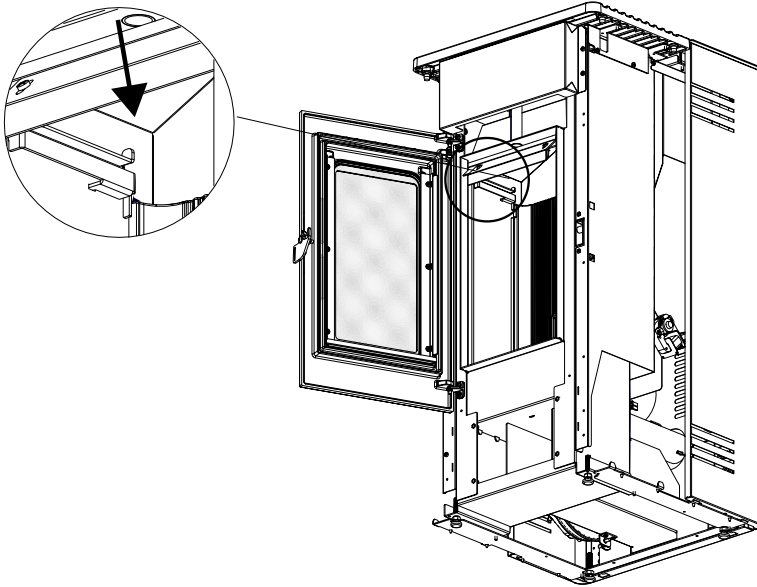

PERIODICAL CHECK OF THE DOOR CLOSURE

Make sure the door closure ensures a correct sealing action (with the "paper sheet" test) and that when the door is closed, the closing block (X in the figure) does not protrude from the sheet metal to which it is secured. For some products it will be necessary to disassemble the cladding to be able to assess the anomalous protrusion of the block when the door is closed.

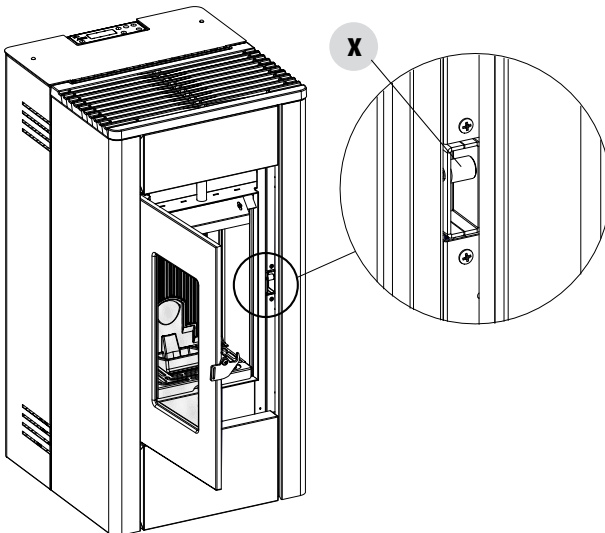

17-CLEANING

CLEANING THE SMOKE DUCT AND GENERAL CHECKS

Clean the smoke outlet system, especially around the Tee fittings, elbows and any horizontal sections of the smoke duct. For information on periodically cleaning the flue, contact a skilled chimney sweep.

Check the seal of the ceramic fibre gaskets on the door of the stove. If necessary, order new replacement gaskets from the retailer or contact an authorised service centre to carry out the operation.



ATTENTION:

The frequency with which the smoke outlet system is cleaned depends on the use of the stove and the type of installation.

We recommend relying on an authorised service centre for end-of-season cleaning and maintenance, as they will carry out all of the previously mentioned work and inspect the stove components.

CLEANING REAR OUTLET

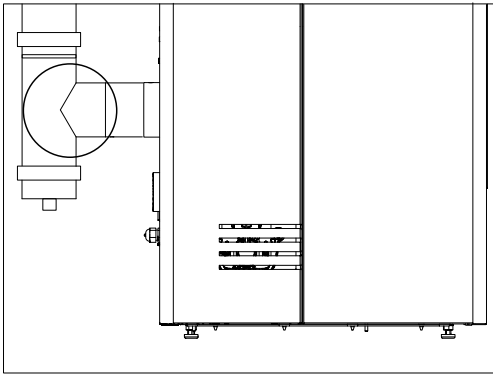

"T" FITTING

CLEANING TOP OUTLET

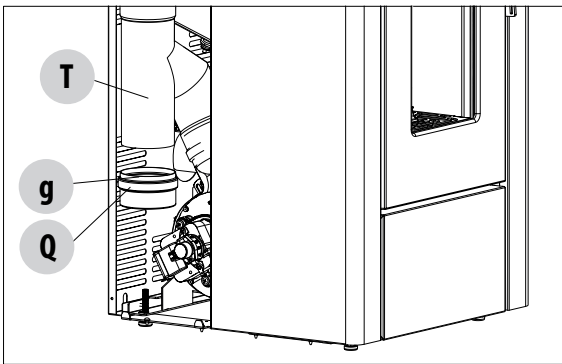

When the side panels have been taken down, clean the smoke pipe.

Remove the cap "Q" and the gasket "g". Then clean the pipe "T", the cap "Q" and replace the gasket "g" if necessary.

17-CLEANING

SHUTDOWN (end of season)

At the end of each season, before switching the product off, it is recommended to remove all the pellets from the hopper with a vacuum cleaner with a long pipe.

We recommend removing the unused pellets from the hopper because they can retain moisture. Disconnect any combustion air ducting that can lead to moisture inside the combustion chamber but, above all, ask the specialised technician to refresh the paint inside the combustion chamber with the special silicone spray paints (available at any store or Technical Assistance Centre) during the necessary annual end of season scheduled maintenance operations. This way the paint will protect the inner parts of the combustion chamber, blocking any type of oxidative process.

When not in use the appliance must be disconnected from the mains power supply. It is recommended to remove the power cable for additional safety, especially in the presence of children.

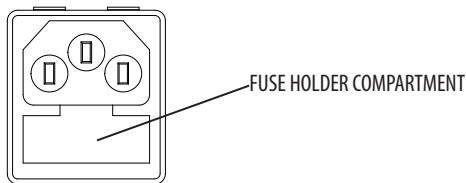

The service fuse may have to be replaced if the control panel display does not switch on when the product is switched on again by pressing the main switch on its side.

There is a fusebox on the side of the product, near the power socket. After having unplugged the appliance, open the fusebox cover with a screwdriver and replace the fuses if necessary (5x20 mm T delayed/ 3. 15 A 250 V) - seek assistance from an authorised and qualified technician.

CHECKING THE INTERNAL COMPONENTS



ATTENTION!

The internal electromechanical components must only be checked by qualified personnel whose technical expertise includes combustion and electricity.

We recommend for this yearly maintenance to be carried out (with a scheduled service contract). This operation consists of a visual and functional inspection of the internal components. A summary of the checks and/or maintenance operations that are essential for the correct operation of the product is provided below.

| PARTS/FREQUENCY | 1 DAY | 2-3 DAYS | 1 YEAR |
|---|-------|----------|--------|
| Brazier | • | | |
| Ash compartment | | • | |
| Glass | | • | |
| Lower exchanger | | | • |
| Complete heat exchanger | | | • |
| Smoke duct | | | • |
| Door gasket | | | • |
| Remote control battery (if purchased/optional) | | | • |
| Door closure operation | | | • |

18-FAULTS/CAUSES/SOLUTIONS



ATTENTION:

All repairs must only be carried out by a specialised technician, with the product switched off and unplugged.

| ANOMALY | POTENTIAL CAUSES | SOLUTIONS |
|---|---|--|
| The pellets are not fed into the combustion chamber. | The pellet hopper is empty | Fill the hopper with pellets. |
| | Sawdust has blocked the feed screw | Empty the hopper and remove the sawdust from the feed screw by hand. |
| | Faulty gear motor | <i>Replace the gear motor.</i> |
| | Faulty circuit board | <i>Replace the electric board.</i> |
| The fire goes out or the product stops automatically. | The pellet hopper is empty | Fill the hopper with pellets. |
| | The pellets are not fed | See the previous anomaly. |
| | The pellet temperature safety probe has been triggered | Let the product cool down, restore the thermostat until the lockout is removed and switch the product back on. If the problem persists, contact Technical Assistance. |
| | The door is not closed properly or the gaskets are worn | <i>Close the door and replace the gaskets with original ones.</i> |
| | Unsuitable pellets | Change the type of pellets with those recommended by the manufacturer. |
| | Low pellet supply | <i>Check the flow of fuel following the instructions in the manual.</i> |
| | The combustion chamber is dirty | Clean the combustion chamber, following the instructions in the manual. |
| | Clogged outlet | Clean the smoke duct. |
| | Faulty smoke extraction motor | <i>Check the motor and replace it, if necessary.</i> |
| | Pressure switch faulty or defective | <i>Replace the pressure switch.</i> |
| The product works for a few minutes and then switches off. | Ignition stage not completed | Repeat the ignition stage. |
| | Temporary power outage | Wait for the automatic restart. |
| | Clogged smoke duct | Clean smoke duct. |
| | Faulty or broken temperature probes | <i>Check and replace the probes.</i> |
| | Faulty glow plug | <i>Check the glow plug and replace it, if required.</i> |
| Pellets accumulate in the brazier, the glass of the door gets dirty and the flame is weak. | Insufficient combustion air. | Clean the brazier and check that all the holes are clear. Perform a general cleaning of the combustion chamber and the smoke duct. Check that the air inlet is not obstructed. |
| | Damp or unsuitable pellets. | Change the type of pellets. |
| | Faulty smoke extraction motor. | <i>Check the motor and replace it, if necessary.</i> |

18-FAULTS/CAUSES/SOLUTIONS

| ANOMALY | POTENTIAL CAUSES | SOLUTIONS |
|--|---|---|
| The smoke extractor motor is not working. | No electrical supply to the stove. | Check the mains voltage and the protection fuse. |
| | The motor is faulty. | <i>Check the motor and capacitor and replace them, if necessary.</i> |
| | Faulty motherboard. | <i>Replace the circuit board.</i> |
| | The control panel is broken. | <i>Replace the control panel.</i> |
| The convection air fan never stops. | Faulty or broken temperature control probe. | <i>Check the probe and replace it, if required.</i> |
| In the automatic position, the stove always runs at full power. | Thermostat set to minimum. | Reset the temperature of the thermostat. |
| | The room thermostat is in maximum position. | Reset the temperature of the thermostat. |
| | Malfunctioning temperature probe. | <i>Check the probe and replace it if required.</i> |
| | Faulty or broken control panel. | <i>Check the panel and replace it, if required.</i> |
| The product does not start. | No power supply. | Check that the plug is inserted and the main switch is in the "I" position. |
| | Pellet temperature probe tripped. | Check the recipe parameters. |
| | Faulty fuse. | Replace the fuse. |
| | Pressure switch faulty (lockout indicated). | Insufficient pressure of water in stove. |
| | Clogged smoke outlet or smoke duct. | Clean the smoke outlet and/or the smoke duct. |
| Noisy air fan even though it is set to minimum | High set flame causes ventilation increase | Lower set flame from Adjustments menu |
| No increase in temperature with stove in operation. | Incorrect combustion adjustment. | Check recipe. |
| | Set flame 1 setting (level too low) | Increase power from the settings menu. |
| | Poor pellet quality. | Use pellets from the manufacturer. |

19-CIRCUIT BOARD

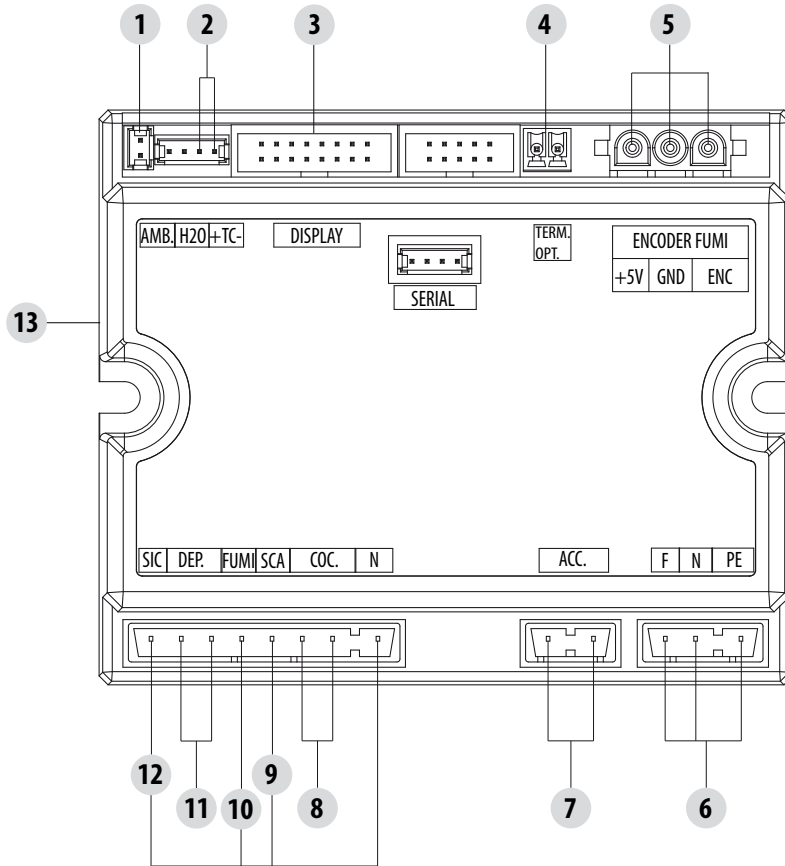

LIVE ELECTRICAL CABLES

DISCONNECT THE POWER SUPPLY CABLE 230V BEFORE CARRYING OUT ANY OPERATIONS ON THE ELECTRICAL BOARDS

WIRING KEY

- | | |
|-----------------------------------|---|
| 1. ROOM PROBE | 8. FEED SCREW |
| 2. SMOKE PROBE | 9. ROOM FAN |
| 3. CONTROL PANEL | 10. SMOKE FAN |
| 4. EXTERNAL THERMOSTAT (OPTIONAL) | 11. AIR PRESSURE SWITCH/DOOR SWITCH/SWITCH PELLET LOADING HATCH |
| 5. SMOKE ENCODER | 12. PELLET SAFETY THERMOSTAT |
| 6. POWER SUPPLY | 13. WI-FI |
| 7. GLOW PLUG | |

PLEASE NOTE The electrical wiring of individual components is fitted with pre-wired connectors of different sizes.



Via La Croce n°8
33074 Vigonovo di Fontanafredda (PN) – ITALY
Telephone: 0434/599599 a.s.
Fax: 0434/599598
Website: www.mcz.it
e-mail: info.red@mcz.it