

OPERATING AND INSTALLATION INSTRUCTIONS

SCAN-LINE 900 SERIES SCAN-LINE 900 SCA SERIES

Scan-line 900 SCA is exempt for use in smoke control areas when burning dry wood
PENDING



www.heta.dk

ECODESIGN READY



EN

DANISH DESIGN . DANISH QUALITY . DANISH PRODUCTION

Congratulations on your new wood stove, we are confident that you will be more than satisfied with your new Heta stove. Especially if you follow the following advice and instructions.

Scan-Line 900 series and Scan-Line 900 Side windows series have been approved according to the EN 13240, NS 3058, NS 3059 and A15 Austria. And the Scan-Line 900 SCA series are modified so that they are also recommended as exempt for use within smoke control areas (SCA) throughout the UK (see clean air act Appendix A) of the air supply regulation so that it can't be closed completely.

Operating Instructions Contents

Before installation.....	3-4
1. Operating instructions.....	5
1.1 Before using	5
1.2 First firing	5
1.3 Regulating the airflow.....	5
1.4 Lighting the stove.....	5
1.5 Refueling	5
1.6 Emptying the ash	6
1.7 Reduced burning.....	7
1.8 Risk of explosion.....	7
1.9 Draft conditions in the chimney	7
1.10 Fuel.....	8
1.11 Operating problems	9
1.12 Chimney fire	9
1.13 Maintenance.....	9
1.14 Cleaning the glass.....	9
1.15 Cleaning the oven	9
1.16 Cleaning behind the oven	10
1.17 Lubricate the moving parts of the stove with graphite spray.....	11
1.18 Diagram for maintenance.....	12
1.19 Garantee.....	12
1.20 Troubleshooting	13
1.20 Cleaning/Replacing bicks after chimney sweeping	
Scan-Line 900 series.....	14
1.21 Cleaning/Replacing bicks after chimney sweeping	
Scan-Line 900 Side windows series	15
1.22 Stove data table EN 13240	16
1.21 Parts	17-21
2. Appendix A.....	22
3. Installation Instructions	23

Heta A/S

Jupitervej 22,
DK-7620 Lemvig

Phone: +45 9663 0600
E-mail: heta@heta.dk

Copyright © 2014
Heta is a registered
trademark of Heta A/S

Printed in Denmark
Subject to printing errors
and changes.

24.08.2023
0037-1545 Version 2,6

BEFORE INSTALLATION

Heta wood stoves are quality products, therefore, your first impression is very important! We have a good logistics network, which transports Heta products with great care for our dealers. Nevertheless, when in transport or handling, damage of the often-heavy stoves can occur. It is important that upon receipt check your Heta product completely and report any damage or defects to your dealer.

The packaging must be disposed of as follows:



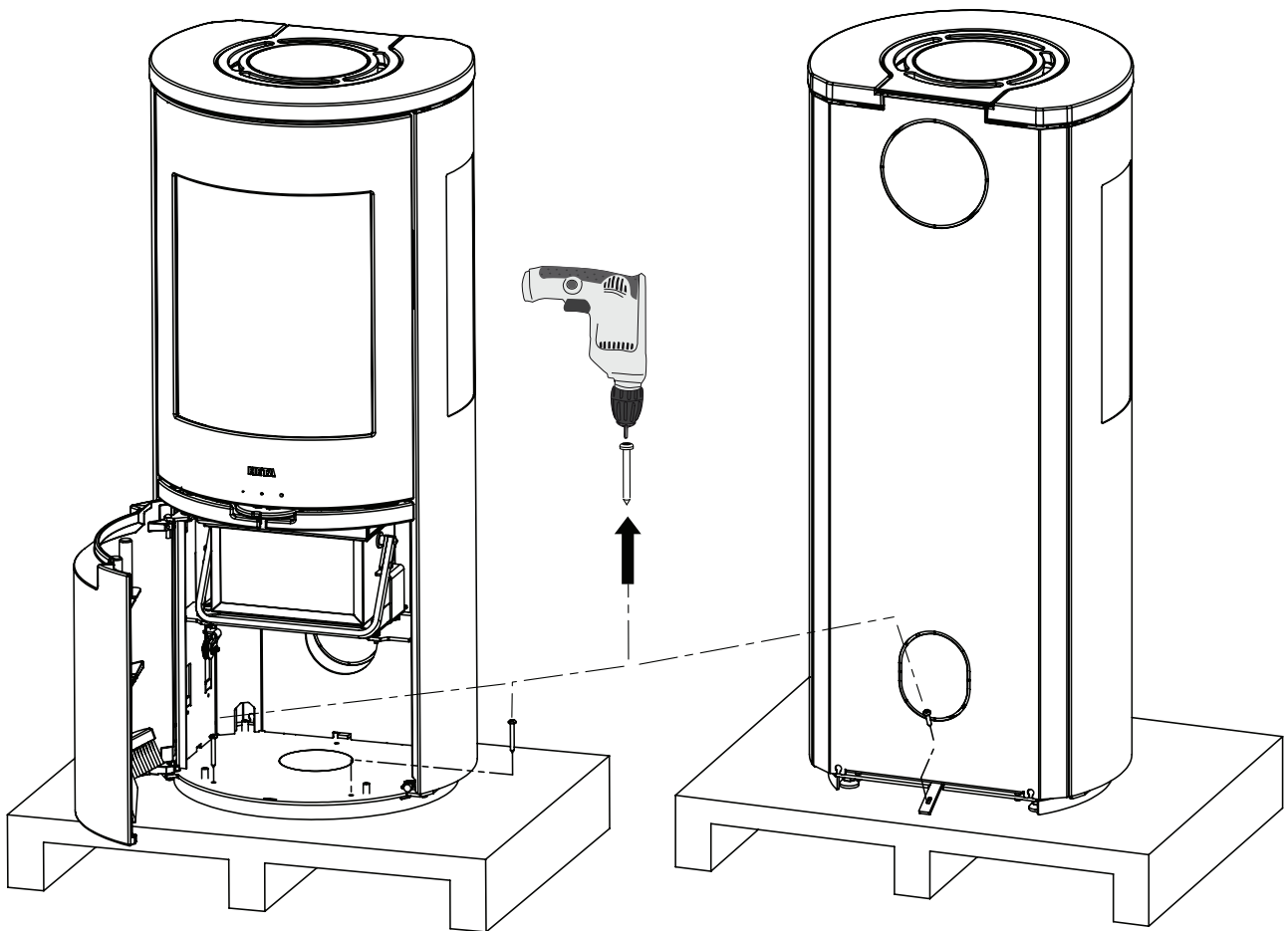

Wood is untreated and able to burn in the stove.

Plastic and cardboard you can drop off at your local recycling center.

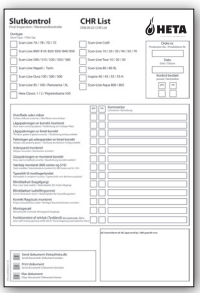

Unpacking the stove

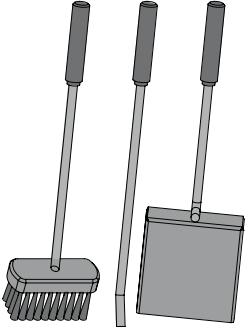

With your new wood stove you should find the following:

<p>Operating / Instruction manual</p>		<p>Q.C. check</p>	
<p>Heta glove 0023-9002</p>		<p>Tool set</p>	
<p>Data plate</p>		<p>Graphite spray for lubrication 0027-0130</p>	

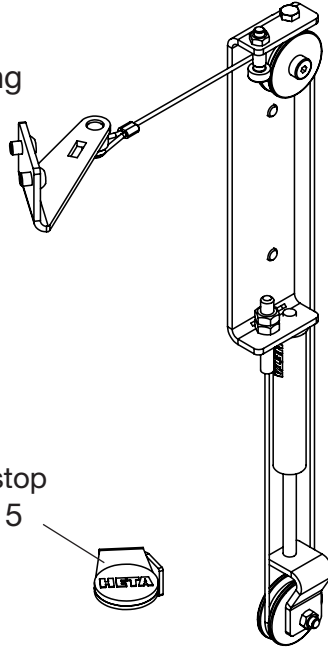
Required tools are not supplied.

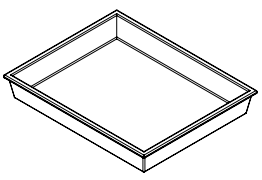
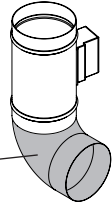
<p>Accessory Complete self-closing mechanism Nr. 6000-012419</p>  <p>Holder for door stop Nr. 6000-012415</p> 	<p>Accessory Blanking plate cast iron (Back outlet) Nr. 0030-2410</p> 
<p>Accessory Roasting pan for oven Nr. 0050-0304</p> 	<p>Accessory Purchased part for HAC with external fresh air through the back plate. Nr. 0050-0521</p> 

1. OPERATING INSTRUCTIONS

1.1 Before using

Before the wood stove is used make sure required installation conditions, are met. See page 21.

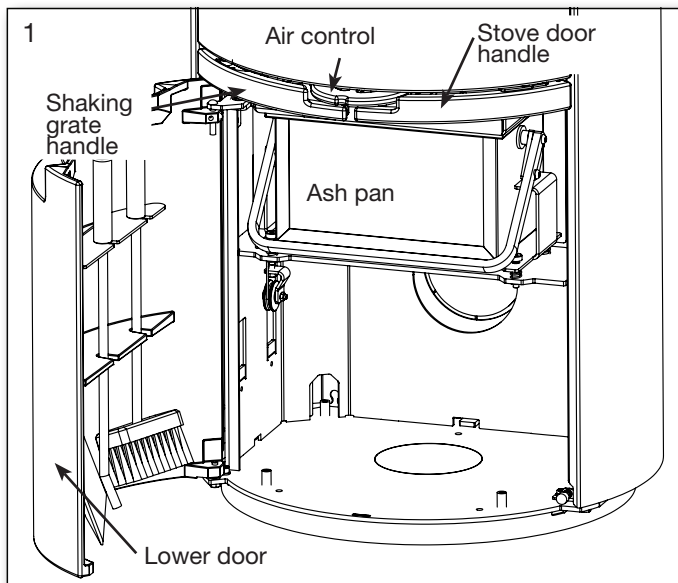

1.2 First firing

The stove paint is fully cured from the factory, but a minor unpleasant odour could still arise.

1.3 Regulating the air flow

The stoves combustion air is regulated by means of a handle below the firing door. See fig. 2.

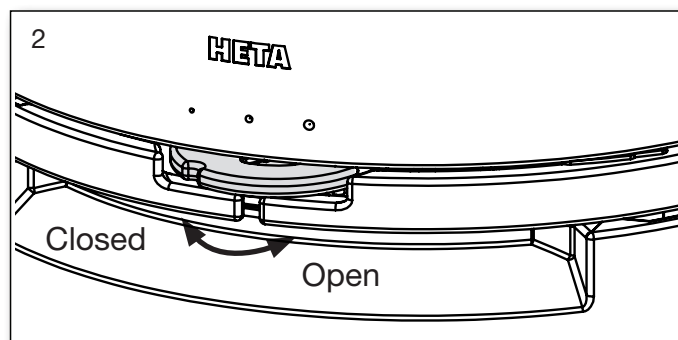

Scan-Line 900 SCA series stoves are designed and tested to burn extremely cleanly with very little smoke discharge and are exempt for use in smoke control areas throughout the UK when burning dry wood logs. To comply, a permanent stop is fitted to ensure that the air control slider cannot be closed beyond 24% Scan-Line 900 series and 40% Scan-Line 900 Sidewindows series of its fully open position. A permanent amount of air will therefore enter the firebox to feed the fire producing negligible amounts of smoke and unburnt hydrocarbons. The appliances will only be considered as an exempt appliance if this stop is in place.

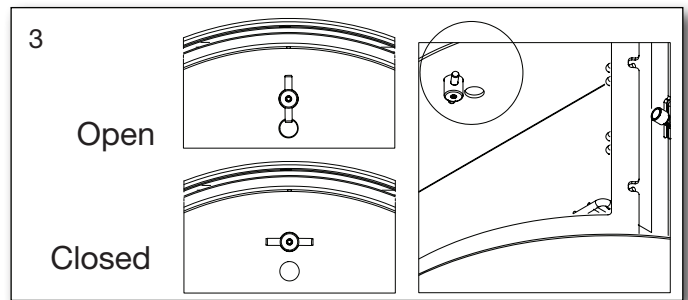

Before lighting, it is very important that the vent in the baking oven is closed.

See fig. 3.

1.4 Lighting the stove

Place two pieces of wood on the bottom. Stack kindling on top in layers with air between. Set ting fire starter (bag, brick, paraffin) on the top, now you are ready to light the fuel. The flames must work from the top down.

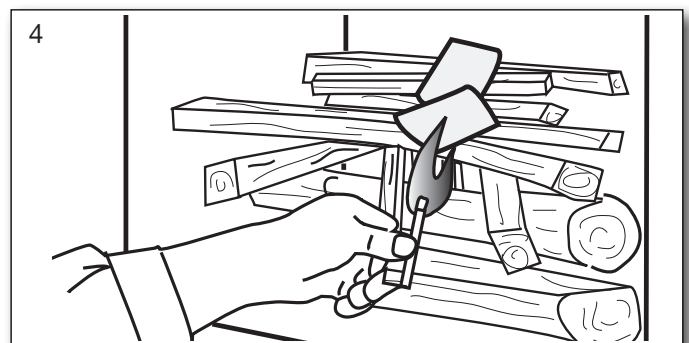

The use of lighter fluid, oils or any liquid fuels is strictly forbidden from use in a wood stove.

Fully open the combustion air and leave the door ajar (about 1 cm open).

Once the fire is established and the chimney is hot (after about 3-5 minutes) closed door and regulate the air into operating position. We recommend, all of the first fuel is burned with the combustion air fully open in the operating position. This ensures the stove and chimney are thoroughly heated.



The Scan-Line 900 series has been safety tested with a load of 2.4 kg of wood and Side windows 2.6 kg of wood.

The warranty will be voided if this amount is exceeded.



Startup/Lighting

Scan the code and select a language.

1.5 Refueling

Refueling of your stove should be done while there is still a good layer of embers. You should therefore air well when using the stove for the first time.

Spread the embers over the base grate, with most towards the front of the stove. Place firewood equivalent to 1.52 kg (Scan-Line 900 series) and 1.71 kg (Scan-Line 900 Side windows series) on top of the embers in one layer, perpendicular to the chamber opening. Fig. 5.

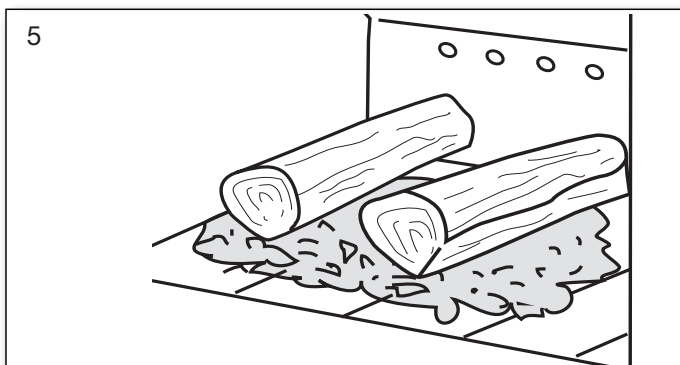

Now open the combustion air completely. If the stove and/or chimney cools down too much, it may be necessary to have the door ajar. The wood will then ignite within a very short time (Typically 1 to 3 minutes). Once the fuel is ignited. Close the door and regulate the air back to operating air. When the fire is well established, you can now regulate the operating air to the desired combustion level.

The nominal output of SL 900 - 6.8 kW, SL 900 Side windows - 6.6 kW is equivalent to a firing interval of approx. 50 minutes at:

Stove type	Open combustion air vent %	Quantity of firewood kg.
Scan-Line 900 series	31	1,52
Scan-Line 900 Side windows series	40	1,71

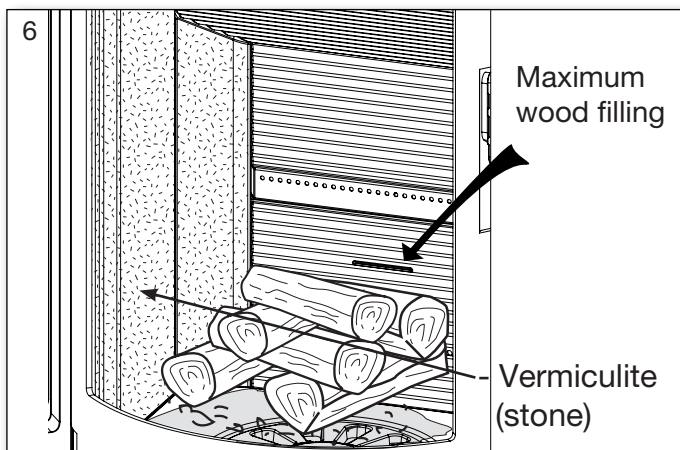

The door must be closed during operation.

Ensure when refueling that the wood is not too close, it will cause poorer combustion, less heat out-put and lower efficiency.



When refueling be careful to place the fuel into the combustion chamber gently, (use the provided glove). By not doing so you risk cracking or breaking the vermiculite.

If there is reduced draft in the chimney, we recommend opening a window at stoking. This will give better ventilation to the room and more oxygen for combustion.

1.6 Emptying the ash

By using the shaker grate, it rotates back and forth so the ash falls through the holes and into the ashtray, see fig. 7. It is advantageous to leave a layer of ash in the bottom of the combustion chamber on top of the grate as insulation.



Be careful when emptying the ashes out. There can be hot embers left for a long time.

Never empty ash into a combustible container.

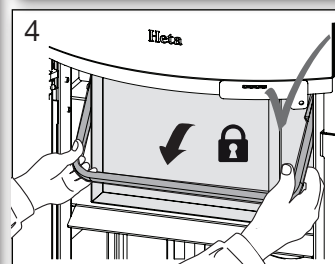
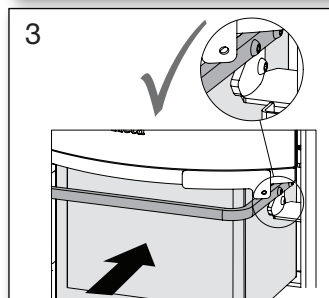
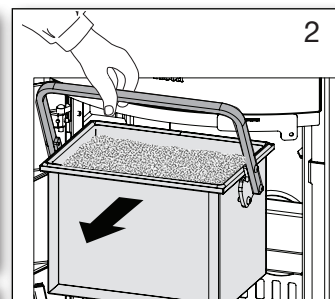
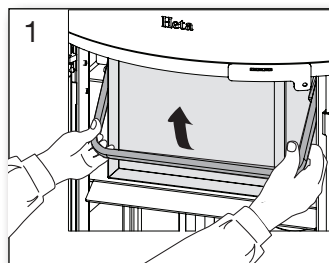
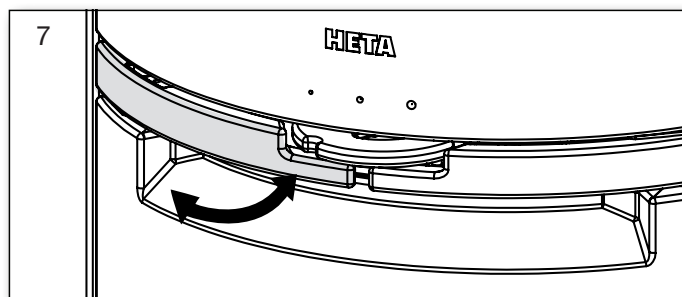



The ashtray must be secure and must not be able to move after being set in place.

Do not fire in the oven if the ashtray is not in place.

The warranty is void if it is not complied with.

1.7 Reduced burning

The stove is, approved for intermittent use.

Never turn down the air down so much that there does not come any flames from the tree. Wait to close the air until the flames have burnt out and the tree is transformed into glowing charcoal.

If you are looking for less heat out-put, achieve this by fueling with smaller volumes of wood and a lower operating air. You may not completely close the operating air during firing.

Be aware that the stove will naturally soot if the operating air is too low. This is not good for the environment. There is also a risk for the glass, the chimney and other parts will become sooted.

By a combination of the above and possibly burning damp wood. Can lead to high levels of soot that it becomes sticky. Causing the sealing of the door to tear off when opening the door the next day.



Never use the stove if the seals are loose.

1.8 Explosion!!!



It is very important never to leave The stove after start up or refueling, before the fire is established. (Typically 1/2 -1 minutes)

Explosion hazard may be possible, if filled with too much wood on the stove and the air supply is too low. As large amounts of gas are being developed and this may cause a flue gas explosion.

Warning!



One must always use caution around the stove when seen, as it gets very warm during use. (In excess of 90° C).

Children should avoid contact with the stove.

Setting up a fence if you have small children may be necessary.

Do not place flammable objects like drying racks, furniture, curtains too close to the stove.

1.9 Draft conditions and the chimney

Poor draft will not allow the stove to burn, as it should. The glass can soot, requires cleaning of the chimney more often, smoke can escape out when the door is open and it gives poor fuel efficiency. Leading to unnecessary polluting of the environment.

Good draft will allow the stove to achieve optimal combustion and the highest possible efficiency. Heta wood stoves are constructed so that it itself provides an optimal blend of combustion air. This provides a high efficiency/heat, clean glass and low environmental impact.

Minimum chimney draft: 10 PA for Scan-Line 900 series and 12 PA for Scan-Line 900 Side windows series. It is the draft that the stove has been tested and approved on. The minimum draft is necessary to provide clean burning, beautiful flame picture, as well as achieving the rated efficiency.

There is a risk of smoke escaping into the room if the door is opened during vigorous firing, or if there is a lack of air supply to the room, for ex. if an extraction fan is in use.

Nominal fluegas temperature:

251° Scan-Line 900 series, relative to 20°C.

265° Scan-Line 900 Side windows series, relative to 20°C.

Scan-Line 900 series:

Flue gas flow is: 5.0 g/sec.

Corresponding to 18 m³ / hr of combustion air by burning 1.52 kg of wood.

Scan-Line 900 Side windows series:

Flue gas flow is: 5.0 g/sec. Corresponding to 18.0 m³ / hr of combustion air by burning 1.71 kg of wood.

The chimney height and diameter, as well as the temperature difference between the flue gas and outside temperature generates the chimney draft. Chimney insulation is therefore important as new efficient stoves create lower flue temperatures. Wind and weather conditions also influence draft, in some cases it may be disadvantageous wind direction, combined with the position of the chimney can cause negative draft (it blows through the chimney), causing smoke escape from the stove.

Before using after a long period of inactivity, check that the chimney is free for any blockages. (soot build-up, bird nests, leaves etc.).

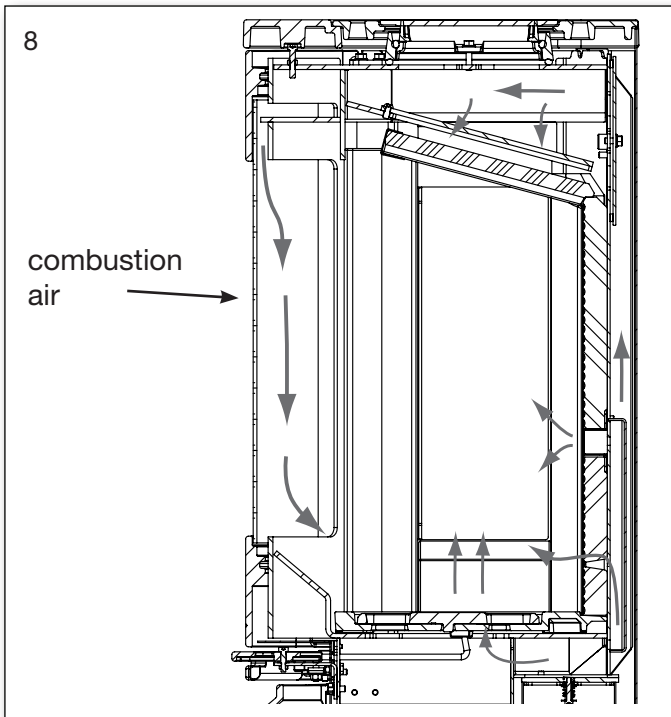

Reduced draft can occur when:

- The temperature difference is too small between smoke gasses and outdoor temperature, for eg. poorly insulated chimney
- Too short of a chimney
- The outside temperature is high, and indoor temperature is low for eg. in summer
- False air in the chimney
- Chimney is blocked
- Air tight house (lack of combustion air supply)
- Poorly placed chimney for the surroundings, for ex. the ridge and trees may cause turbulence

Good draft occurs when:

- The difference in temperature in the chimney (warmer) and outside temperature (colder)
- It is clear weather
- The chimney has the right height min 4 meters above the stove, and clear of the roof ridge.

1.10 Fuel

Your new stove is EN approved for firing with wood fuel. You must therefore only burn clean, dry wood in your stove. Never use your stove to burn driftwood, as this may contain a lot of salt which can damage both the stove and the chimney. Similarly, you must not fire your stove with refuse, painted wood, pressure-impregnated wood or chipboard, as these materials can emit poisonous fumes and smoke.

Correct firing using well seasoned wood provides optimal heat output and maximum effi-

ciency. At the same time, correct firing prevents environmental damage in the form of smoke emissions and reduces the risk of chimney fires.

If the wood is damp and inadequately seasoned, a large proportion of the energy in the fuel will be used to vaporize the water and this will all disappear up the chimney. Thus, it is important to use dry, well seasoned wood, for eg. wood with a moisture content of less than 20 %. Achieve this by storing the wood for 1–2 years before use.

Pieces of firewood with a diameter of more than 10 cm should be split before before storing. The pieces of firewood should be of an appropriate length (approx. 20 cm) so that they can lie flat on the bed of embers.

If you store your wood outdoors, it is best to cover it.

Examples of fuel values

for different woods and their typical densities per cubic meter, specified for 100% wood with a moisture content of 18%.

Wood	kg/m ³	Wood	kg/m ³
Beech	710	Willow	560
Oak	700	Alder	540
Ash	700	Scotch pine	520
Elm	690	Larch	520
Maple	660	Lime	510
Birch	620	Spruce	450
Mountain pine	600	Poplar	450

It is advised not to use oil-containing woods like teak tree and mahogany, as this can cause damage to the glass.

Heating value in wood

You have to use about 2.4 kg normal wood to replace one litre of heating oil. All woods have almost the same heating value per kg, which is about 5.27 kW/hour for absolute dry wood. Wood with a moistness of 18% has a efficiency of about 4.18 kW / hour per kg, and one litre heating oil contains about 10 kW / hour.

CO₂ release

At combustion 1000 litres of heating oil forms 3.171 tons CO₂. As wood is a CO₂ neutral heat/energy source, you save the environment about 1.3 kg CO₂ every time you have used 1 kg normal wood.

1.11 Operational problems

The chimney must be swept at least once a year, we recommend the use of a NACS (national association of chimney sweeps) registered chimney sweep.

In the event of smoke or malodorous fumes are being produced, you must first check to see whether the chimney is blocked.

The chimney must, of course, always provide the minimum draft necessary to ensure that it is possible to regulate the fire. Please note, however, that chimney draft is dependent on the weather conditions. In high winds, the draft can become so powerful that it may be necessary to fit a damper in the flue gas pipe to regulate the draft.

When cleaning the chimney, soot and other deposits may come to fall on the baffle plate, remove and clean it. In cases where the wood burns too quickly, this may be due to excessive chimney draft. You should also check to make sure that the door seal and ash pan seal is intact and correctly fitting. If the stove is generating too little heat, this may be because you are firing with wet wood. In this case, much of the heating energy is used to dry the wood, resulting in poor efficiency, potentially damaging the vermiculite and an increased risk of soot deposits in the chimney.

1.12 Chimney fire

In case of a chimney fire, which often results from incorrect operation/maintenance or prolonged use of damp wood, close the door and the air supply completely, to help slow/smother the fire.

Call the fire department. The stove and chimney must be inspected before use again.

1.13 Maintenance

The surface of the stove is treated with a heat-resistant paint. The stove should be cleaned with a damp cloth.

Any damage to the surface in the form of chips or scratches can be repaired using touch-up paint, which is available in spray can

1.14 Cleaning the glass

Incorrect firing, for example using wet wood, can result in the viewing window becoming covered in soot.

This can be removed easily and effectively using glass cleaner applied using a cloth.

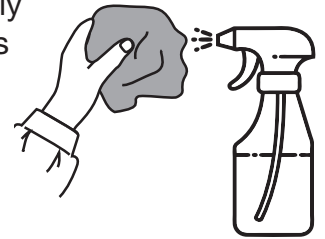

Never apply spray directly to the glass.

1.15 Cleaning the oven

You should attempt not to spill anything directly onto the oven coating. Where necessary, use an aluminium tray or a Heta roasting tin no. (no. 0050-0304) to catch any spills.

Clean the oven using hot water and washing-up liquid. Do not use oven cleaner as this may damage the surface.

Remove and clean the wire rack and bars. See Fig. 1-5

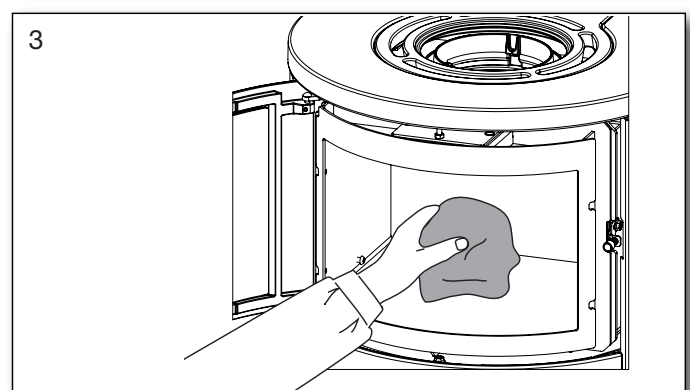
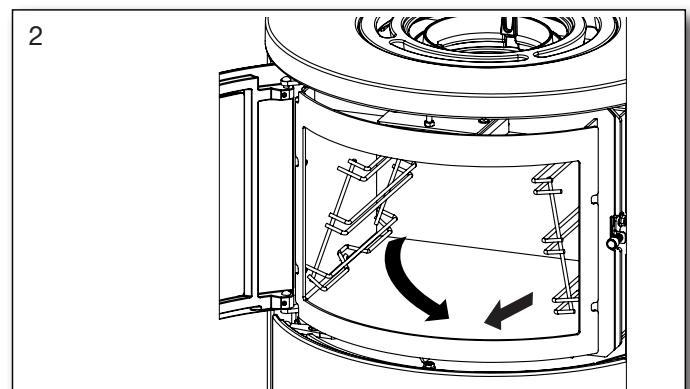
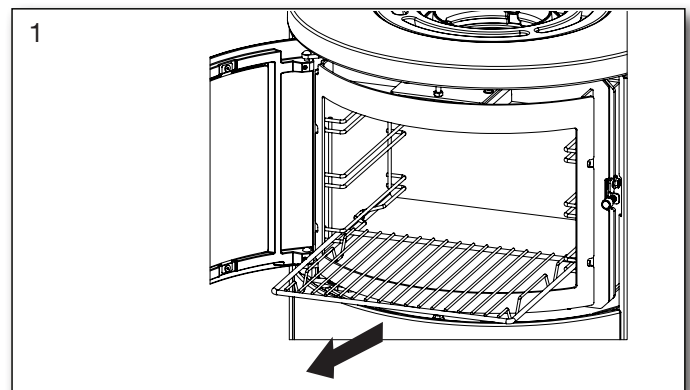

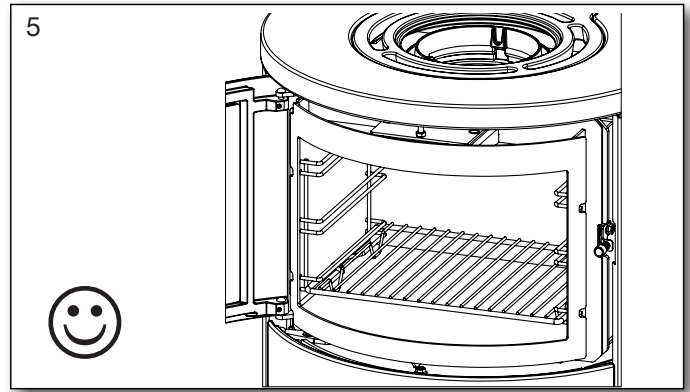
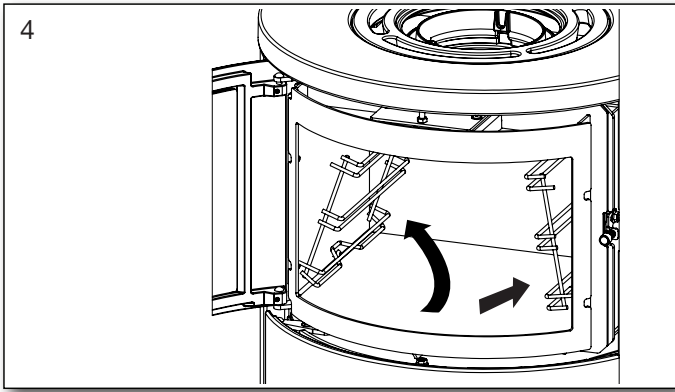

1.16 Cleaning behind the oven

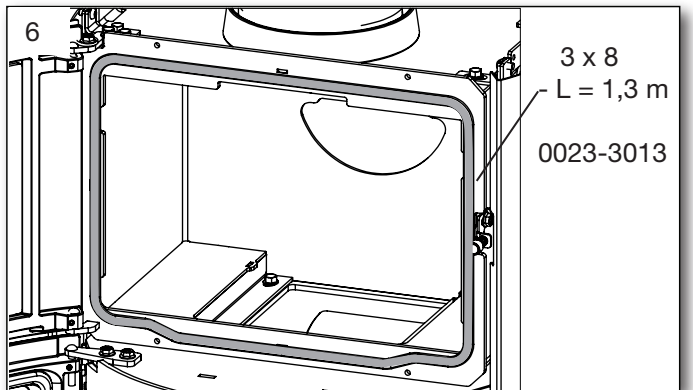
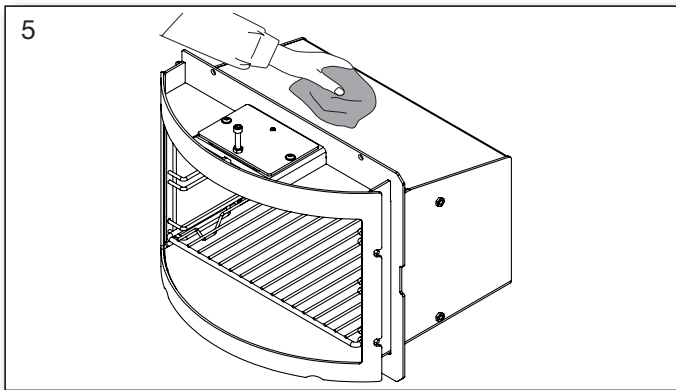
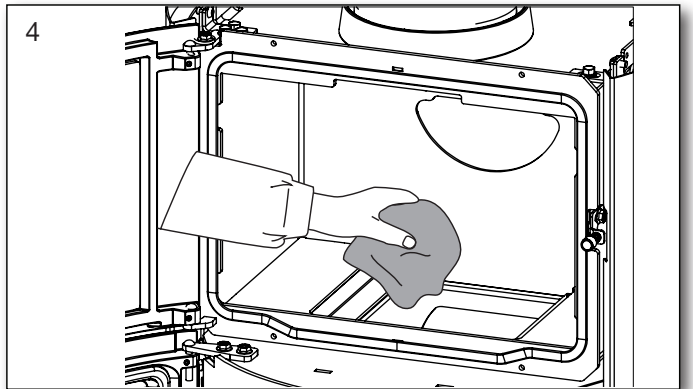
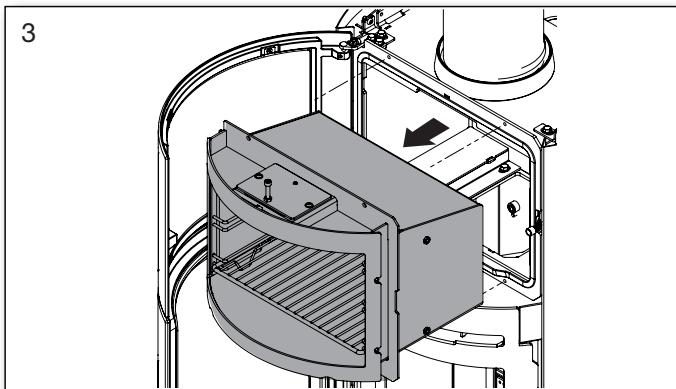
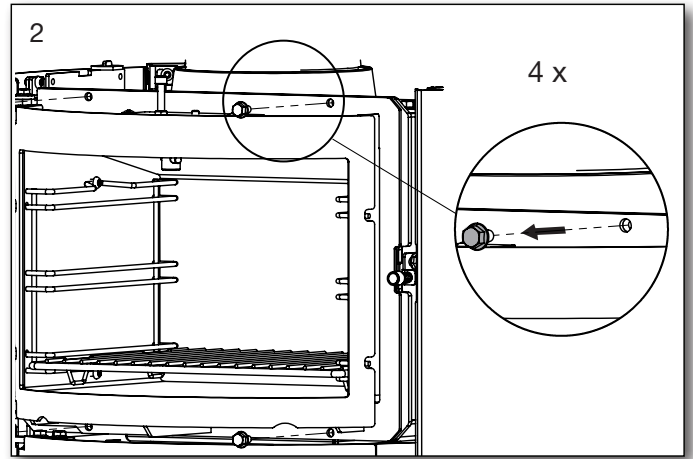
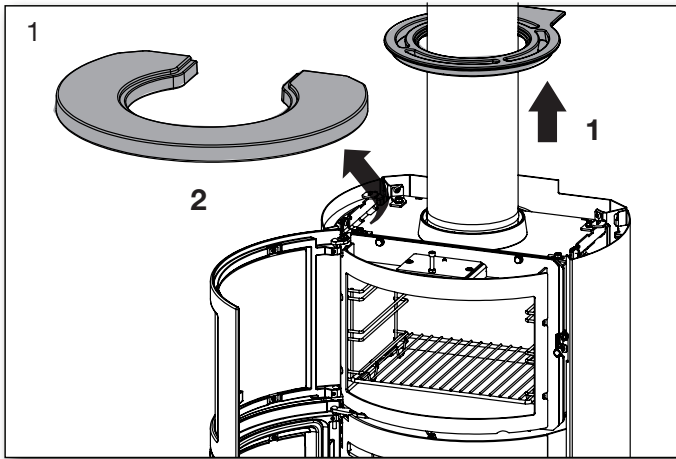

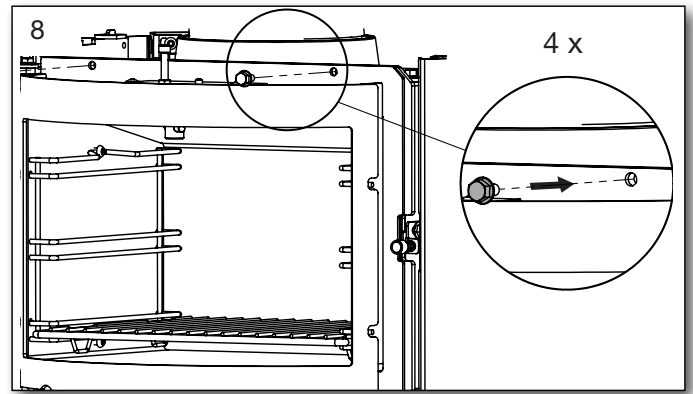
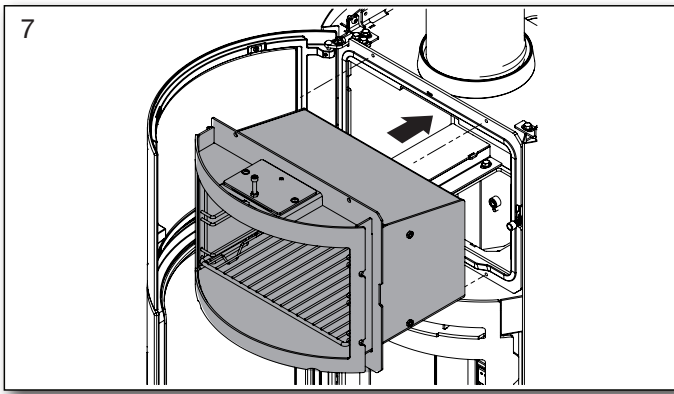

1.17 Lubricate the moving parts of the stove with graphite spray



Before using graphite spray, you should cover the exposed surfaces so that lubricants are applied only to the moving parts.

Always test the graphite spray on a hidden surface to make sure the can is working as intended.

Graphite spray should only be used on a cold stove.

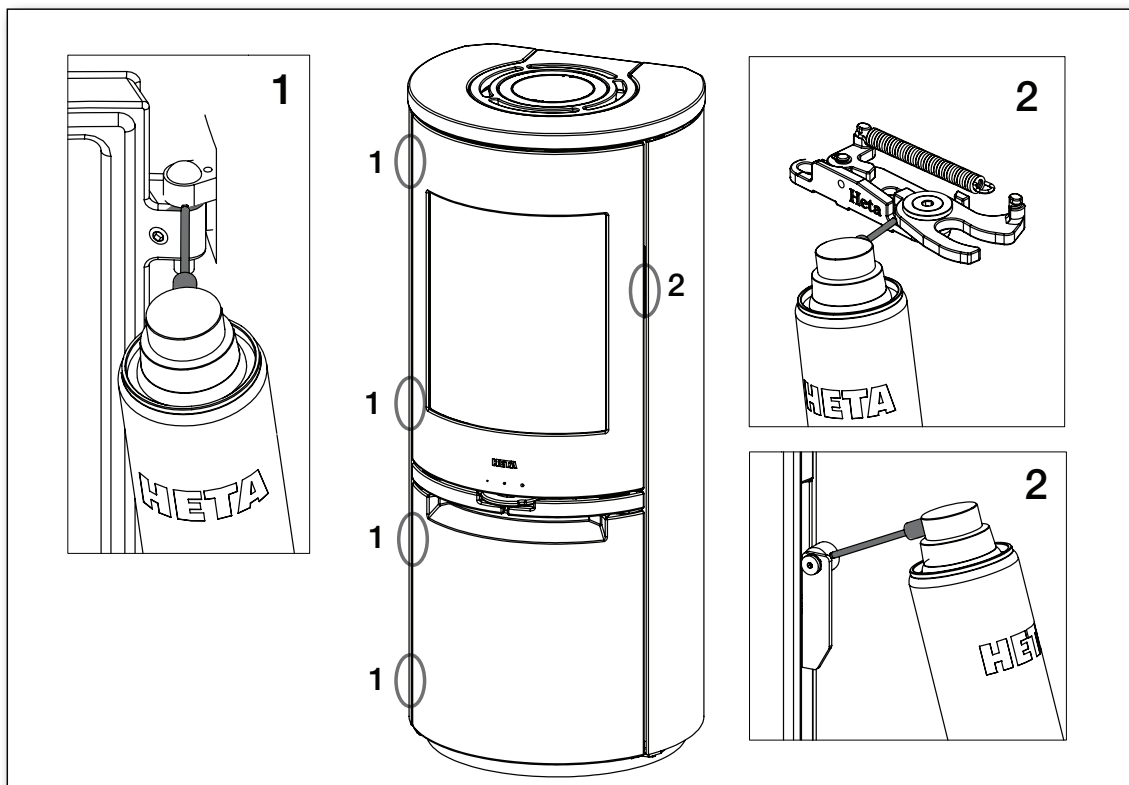
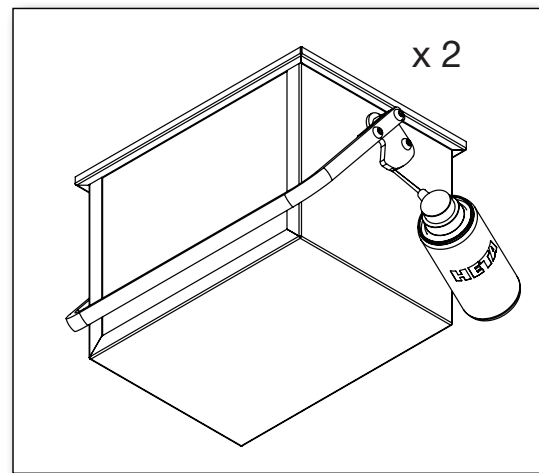

1.18 Diagram for the maintenance

Maintenance / Period	Stove Owner					Qualified Technicia	
	Before Autum	Daily	1 week	30 days	60-90 days	1st Year	2st Year
Cleaning the chimney (see. Chimney)	C						
Cleaning the chimney and stove	C				C		
Cleaning the stoves firebox	C	VI			C		
Cleaning combustion air intake	C				C		
Cleaning ash bucket	C		VI	C			
Cleaning of the firebox	C		VI	C			
Checking / switch, gasket for door	C/S	VI					C/S
Checking / changing, gasket for glass	C/S	VI					C/S
Checking / switch, gasket for ashpan	C/S	VI					C/S
Checking / changing gasket for flue pipe	C/S	VI					C/S
Checking / changing vermiculite	C/S	VI					C/S
Lubricate hinges	L	VI			L		
Lubricate lock	L	VI			L		
Lubricate Ash pan	L				L		

C = Cleaning

L = Lubricate whit graphite spray

C/S = Checking / Switch

VI = Visual Inspection, pos. cleaning/replacing/adjusting

1.19 Guarantee

Heta wood stoves, are subjected to a strict quality control during production and before delivery to the dealer. Therefore, the duration of the warranty is **5 years** on this product, covering manufacturer's defects, **1 year** on paint adhesion defects from purchase date from Heta and a 3 months total warranty for seals, vermiculite and glass from the date of sale from the dealer.

Claims concerning stoves older than **3 months**, will be assessed by our quality team on a one-by-one basis. Report all claims to your dealer or local Heta representative, who in turn will contact Heta to solve the claim. To file a claim please provide date of installation, picture of the silver data sticker, model and a description of the issue and pictures.

The guarantee does not cover:

- Wearing parts / fragile parts such as:
- Vermiculite elements in the combustion chamber.
- Glass
- Seals
- The cast bottom or shaking grate
- Surface or paint deteriorations due to excessive humidity, salinity or other aggressive environment
- Damage caused by improper use
- Transportation costs for warranty repair
- Assembly / disassembly of warranty repair
- Any secondary damages of the stove or it's environments due to negligence of any initial damages whether this damage is covered or not by the manufacturers guarantee.

Warning



Inadequate installation, unauthorized alteration to the stove or the use of non-original parts will void the guarantee.

1.20 Troubleshooting table - applies to all stove types

Fault	Cause	Troubleshooting	Solution
Lighting problems. When the stove is cold, smoke seeps into the room. Once the combustion chamber has heated up, the stove burns well.	Inadequate chimney draft. The chimney only has sufficient draft when it is hot.	You can test using a lighter whether flame is drawn into the combustion chamber.	Improve the chimney.
The stove burns poorly after the warm-up phase, and the glass slowly soots up.	Soot in the flue pipe.	Check the flue pipe regularly, as the problem arises slowly.	Clean regularly, and limit the use of horizontal flue pipes. Do not use firewood which generates large quantities of ash.
If the stove burns poorly after start-up, and the glass slowly soots up.	Inadequate chimney draft.	The fault usually already occurs during lighting. Measure the chimney draft.	Improve the chimney draft.
	Insufficient air supply.	Check the air supply.	Read the operating instructions and instruct all users.
	Damp wood.	Use clean, dry wood with a maximum moisture content of 20%.	Firewood should ideally be dried for at least one year after splitting.
	Firewood pieces too large.	Optimal size – see the section for firewood, max. diameter 10 cm.	Use smaller pieces of firewood.
	Insufficient air supply to the room. Range hoods, airtight windows, etc.	Ensure there is sufficient fresh air supply, open a window, check the outdoor air supply.	Depending on the cause, windows must be opened or the outdoor air connection cleaned.
	Insufficient air supply to the room. Range hoods, airtight windows, etc	Ensure there is sufficient fresh air supply, open a window, check the outdoor air supply.	Depending on the cause, windows must be opened or the outdoor air connection cleaned.
The vermiculite in the combustion chamber is becoming very worn.	Wood and flue gases wear down the vermiculite.	Investigate whether the wear is normal.	Normal wear and minor cracks are of no significance. It should be replaced when the steel of the combustion chamber is visible.
Too rapid combustion.	Too much chimney draft.	To test, you can open the cleaning hatch, but remember to close it again.	Measure the chimney draft and install a damper in the flue pipe if necessary.
	The door or ash pan/drawer seal is defective.	While cold, close a piece of paper in the door – the seal should hold the paper gently in place so it does not fall out by itself. Normal wear.	Replace the seal.
The vermiculite in the combustion chamber is cracked.	Shocks or impacts while adding firewood.	Normal wear	Cracks only have cosmetic significance. Replace when the steel of the combustion chamber is visible.
Steel surfaces in the combustion chamber have oxidised.	The temperature in the combustion chamber is too high.	Unsuitable fuel is being used (such as coal). Check the quantity of firewood being used, read the operating instructions.	If there are clear cracks or weaknesses in the stove body, it must be replaced.
The stove whistles	Too much chimney draft	To test, you can open the cleaning hatch, but remember to close it again.	Install a damper.
The stove 'clunks'	Usually due to tension in the metal plates.	Generally only occurs while heating up and cooling down.	Adjust the metal plates.
The stove ticks	Normal expansion and contraction due to temperature changes.	A normal sound.	Ensure that the temperature in the combustion chamber is as constant as possible.
The stove creaks.	The temperature in the combustion chamber is too high.	Use less firewood. Also check the seal in the ash pan/drawer.	See the operating instructions.
The stove smells. The surface is steaming.	The paint on the stove surface is not yet fully hardened.	See the operating instructions regarding the first firing.	Ensure there is sufficient ventilation.
Condensation in the combustion chamber.	Moisture in the vermiculite.	Check the condition of the vermiculite.	Evaporates by itself after the stove has been lit a few times.
	Damp wood.	Measure the moisture content.	Use dry firewood.
Condensation from the flue pipe.	The pipe is too long or the chimney is too cold.	Check the flue pipe's length and heat loss.	Improve the flue pipe, insulate the chimney.
	Damp wood	Measure the moisture content.	Use dry firewood.
Moving parts creak.	Needs lubrication.	What part.	Lubercate with graphite spray.

1.21 Scan-Line 900 series. Cleaning after sweeping or before replacing vermiculite stones

Note: it may be necessary to clean/vaccum the holes and air ducts behind the rear stone.

Order of removing Fire bricks.

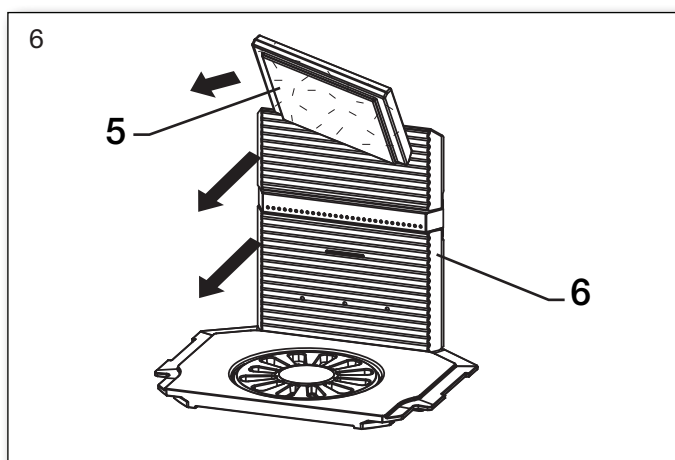
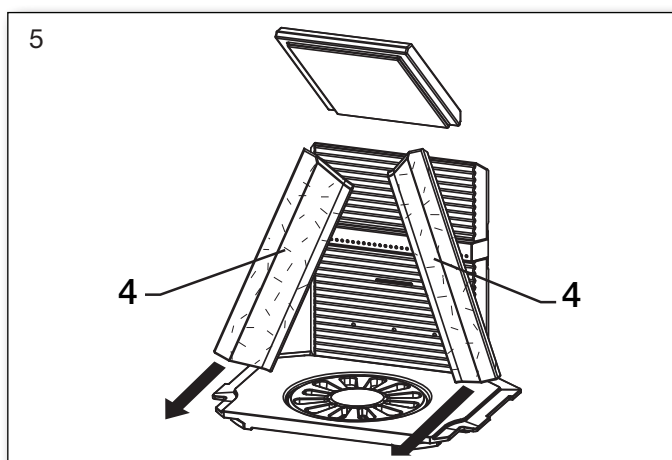
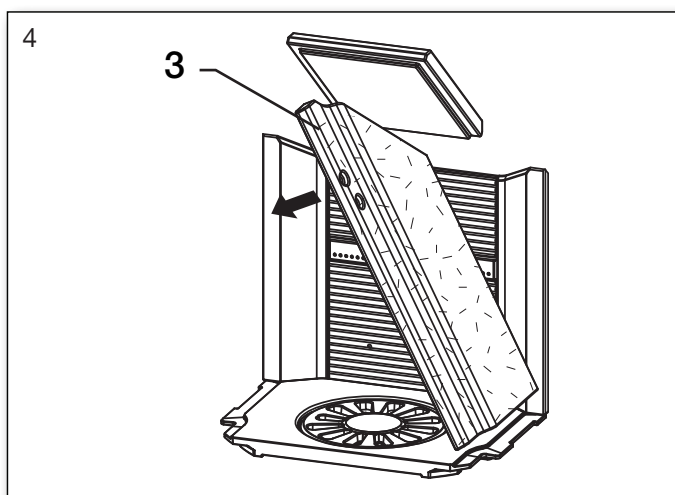
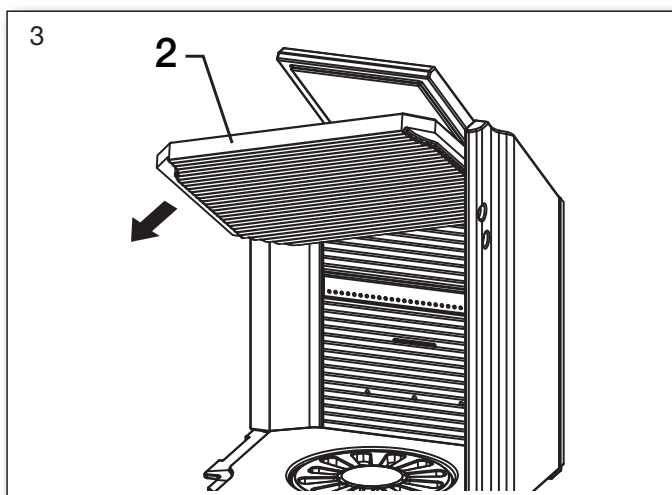
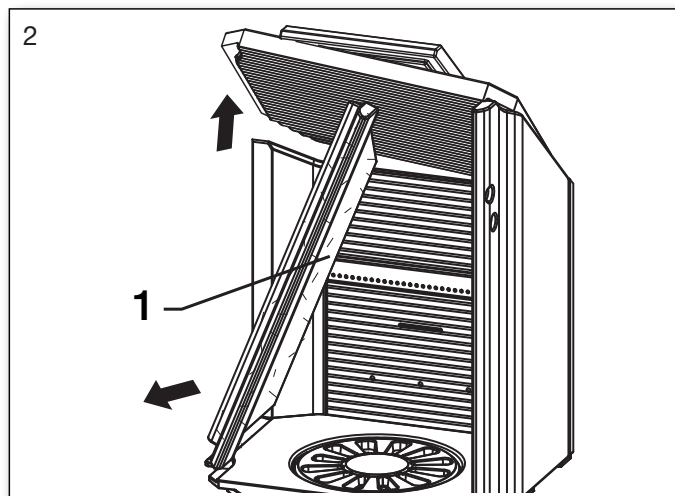
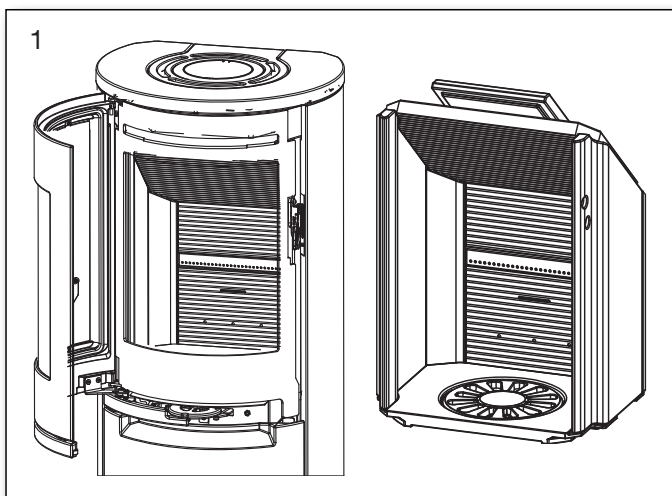

Replace in reverse order. Starting with Fig. 6.

1.22 Scan-Line 900 Side windows series. Cleaning after sweeping or before replacing vermiculite stones

Note: it may be necessary to clean/vaccum the holes and air ducts behind the rear stone.

Order of removing Fire bricks.

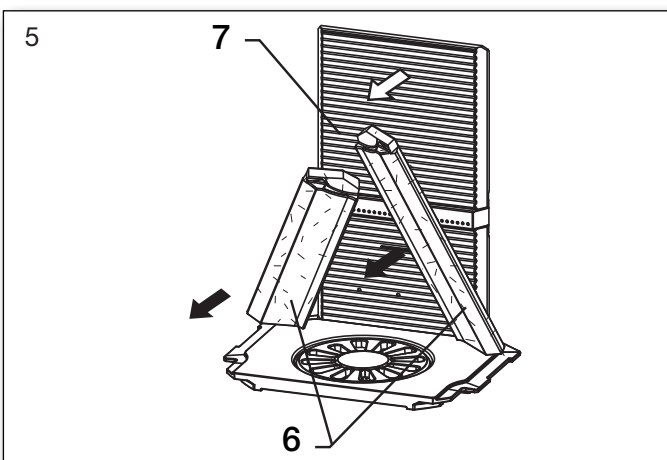
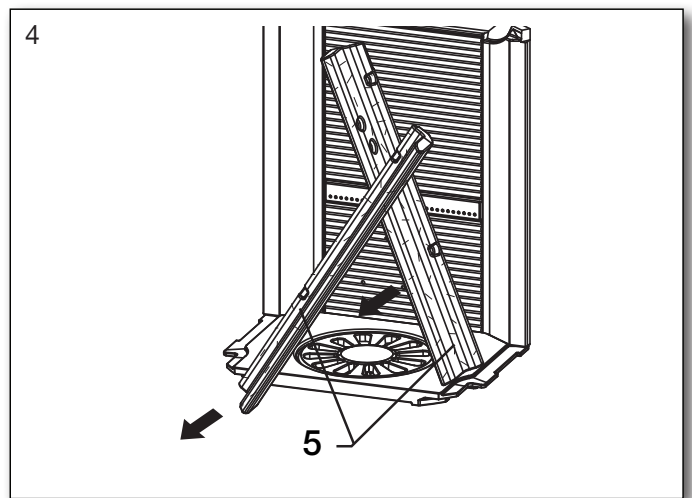
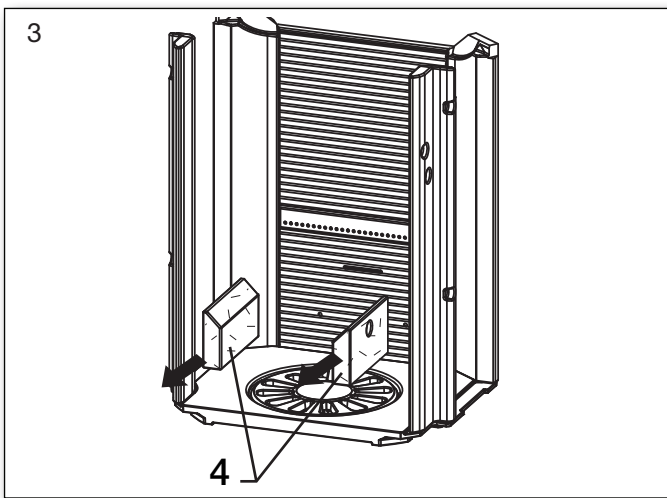
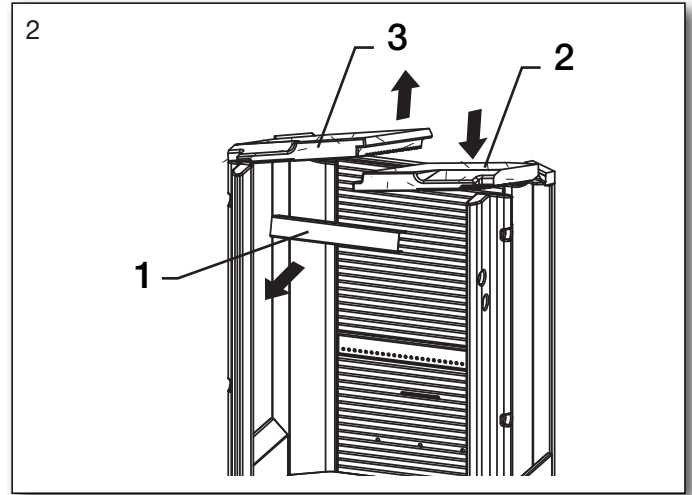
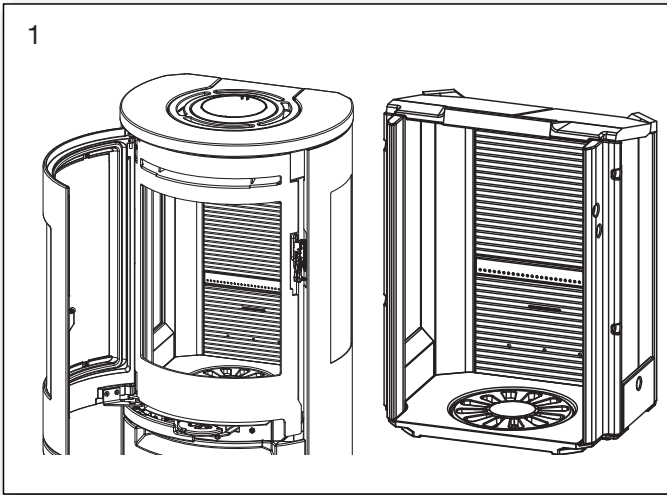

Replace in reverse order. Starting with Fig. 5.

1.23 Stove data table in accordance with en 13240 testing

Tested as a freestanding oven and with uninsulated flue

Stove type	Nominal fluegas temperature, at 20°C room temperature C°	Flue mm	Air intake mm	Fuel volume kg	Draft min. mbar	Nominal output tested kW	Actual efficiency %	Distance to flammable materials			Stove weight kg
								at the side mm	rear the stove insulated/ uninsulated flue pipe mm	to furnitures mm	
Scan-Line 900 series	251	ø150	ø100	1,52	0,10	6,8	83	450	150/150	1150	*
Scan-Line 900 Side windows series	265	ø150	ø100	1,71	0,12	6,6	82	400	125/150	900	*

Average temperature in the flue pipe connector:

Scan-Line 900 series 302° C - Scan-Line 900 Side windows series 318° C.

Scan-Line 900 B = Baking oven

Scan-Line 900 S = Therma stones

Scan-Line 900 B Side windows = Baking oven

Scan-Line 900 S Side windows = Therma stones

Stove models with a glass front on a door have the same weight as stove models with ordinary doors.

* Scan-Line 900 series standard	148 kg.
* Scan-Line 900 full stone	200 kg.
* Scan-Line 900 stone top	156 kg.
* Scan-Line 900 B steel	177 kg.
* Scan-Line 900 B stone	241 kg.
* Scan-Line 900 B stone top	186 kg.
* Scan-Line 900 S steel	217 kg.
* Scan-Line 900 S stone	281 kg.
* Scan-Line 900 S stone top	225 kg.
* Scan-Line 900 Side windows series standard	147 kg.
* Scan-Line 900 Side windows full stone	184 kg.
* Scan-Line 900 Side windows stone top	155 kg.
* Scan-Line 900 B Side windows steel	178 kg.
* Scan-Line 900 B Side windows stone	226 kg.
* Scan-Line 900 B Side windows stone top	186 kg.
* Scan-Line 900 S Side windows steel	217 kg.
* Scan-Line 900 S Side windows stone	265 kg.
* Scan-Line 900 S Side windows stone top	225 kg.

The nominal output is the output to which the stove has been tested.

Testing is conducted with the combustion air open

31% for Scan-Line 900 series. 40% for Scan-Line 900 Side windows series

Stove data table in accordance to Norwegian fire wall

Oventype Stove	Norwegian fire wall			
	Distance to fire wall with 108 mm brick.			
Minimum dimensions in mm	Rear the stove uninsulated flue pipe	At the side uninsulated flue pipe	Length of fire wall forward in front of oven	Length of fire wall next to oven
Scan-Line 900 series	50	150	500	100
Scan-Line 900 Side windows series	50	200	400	200

1.24 Scan-Line 900 series Parts - Inside fire chamber

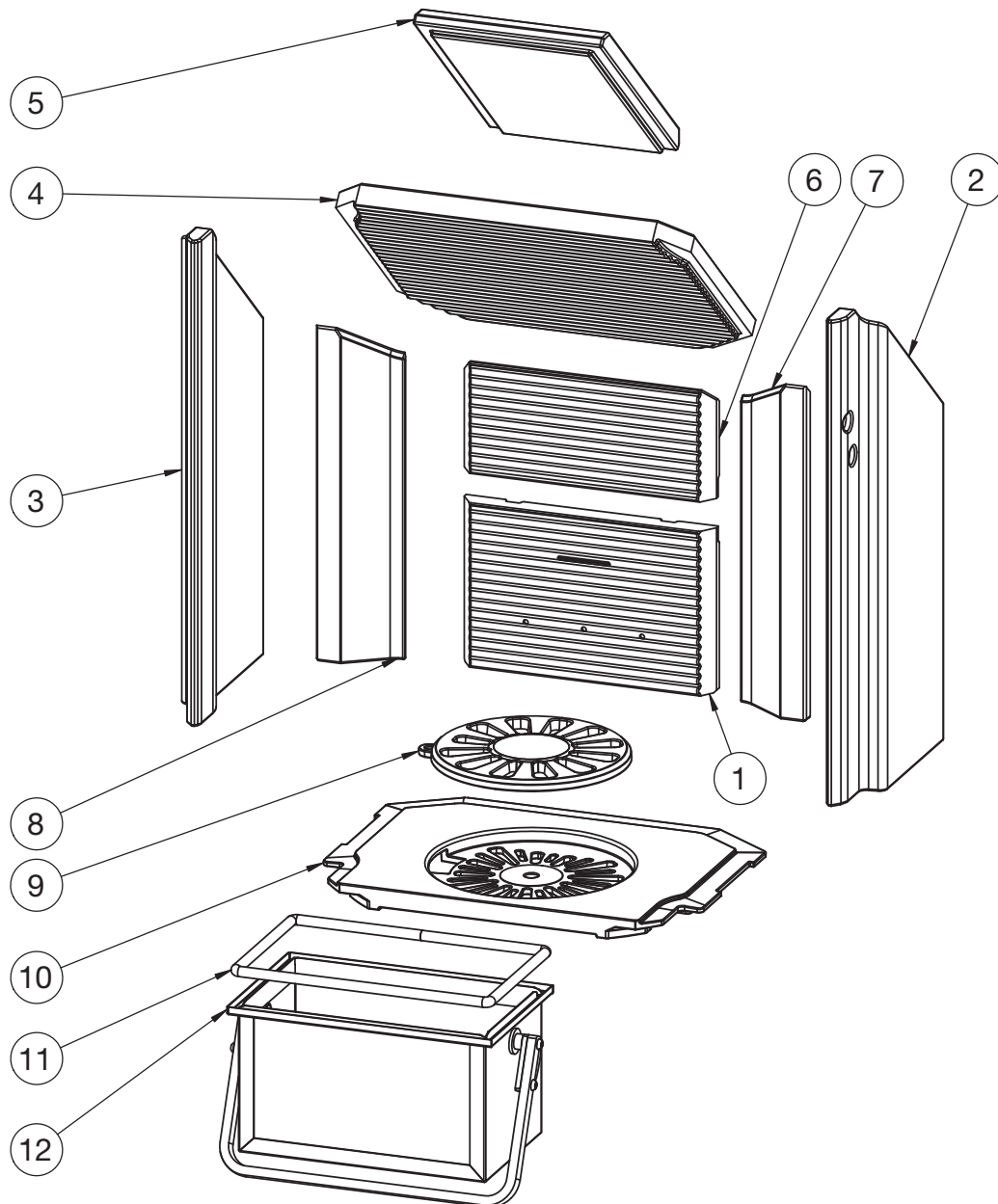

Pos.	No.	Name	Qty.
1	0023-006028	Vermiculite, rear, bottom	1
2	0023-006261	Vermiculite, side, right	1
3	0023-006465	Vermiculite, side, left	1
4	0023-011495	Baffle	1
5	0023-012044	Baffle, small	1
6	0023-012060	Vermiculite, rear, top	1
7	0023-012061	Vermiculite, rear, right	1
8	0023-012062	Vermiculite, rear, left	1
9	0030-0201	Grate, Ø195 mm	1
10	0030-006009	Casted bottom	1
11	0023-3017	Gasket L = 850	1
12	4018-0053	Ash container	1

Scan-Line 900 Side windows series Parts - Inside fire chamber

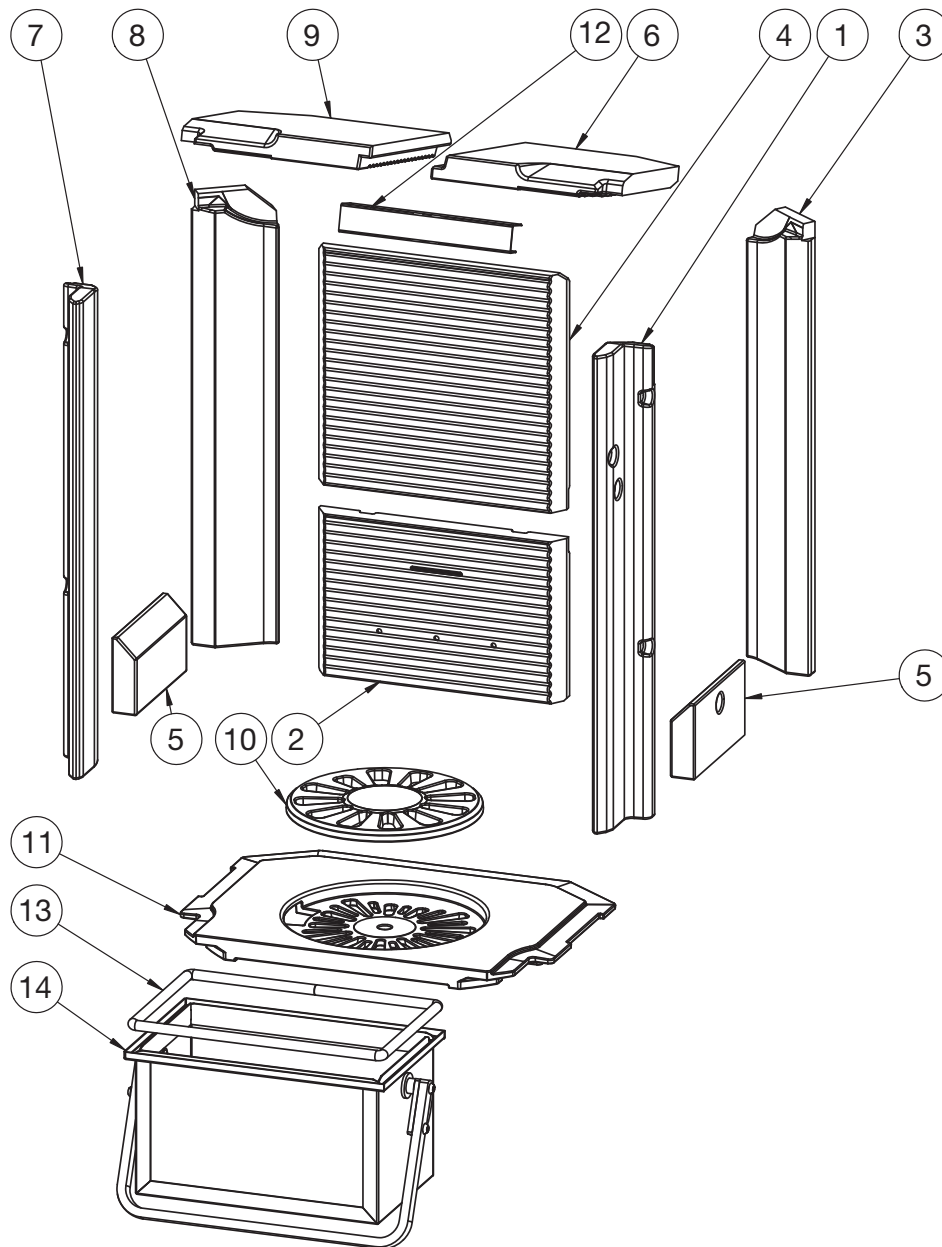

Pos.	No.	Name	Qty.
1	0023-006026	Vermiculite, front, right	1
2	0023-006028	Vermiculite, rear, bottom	1
3	0023-006029	Vermiculite, narrow side, right	1
4	0023-006032	Vermiculite, rear, top	1
5	0023-006050	Vermiculite, under Side windows	2
6	0023-006110	Baffle, two-part, right	1
7	0023-006467	Vermiculite, front, left	1
8	0023-012056	Vermiculite, small side, left	1
9	0023-012057	Baffle, two-part, left	1
10	0030-0201	Grate, Ø195 mm	1
11	0030-006009	Casted bottom	1
12	1013-006262	Baffle rail	1
13	0023-3017	Gasket L = 850	1
14	4018-0053	Ash container	1

Parts - Door

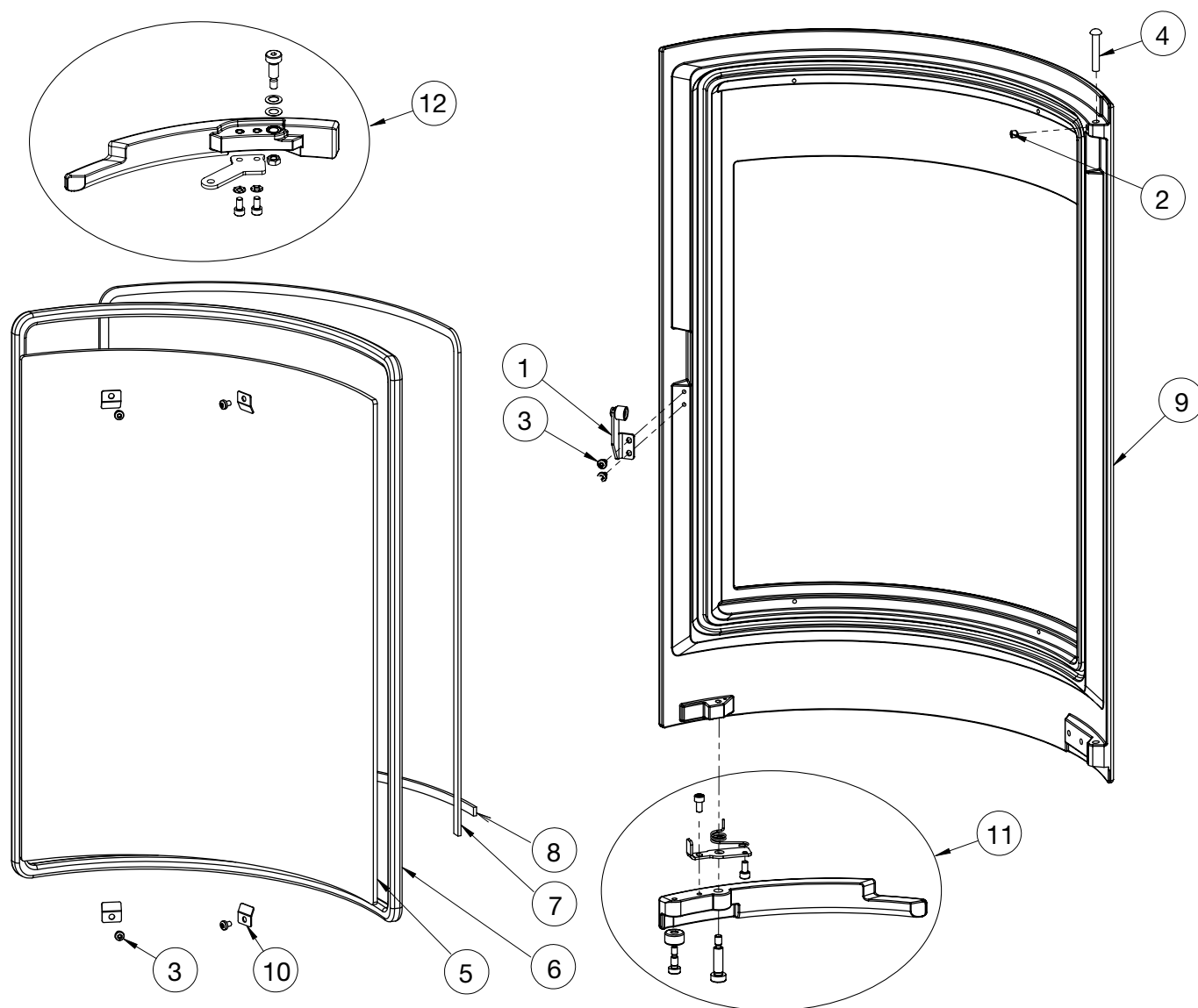

Pos.	No.	Name	Qty.
1	6000-005970	Close roller, completet	1
2	0008-1002	M6x6 Hexagon socket set screw	1
3	0008-2304	M4x6 Hexalobular socket pan head	6
4	0008-9082	6x35 Round head rivet	1
5	0021-006404	Glass	1
6	0023-3008	Glass gasket $\varnothing 12$ L = 1.84 m	1
7	0023-3010	Textile glass 6 mm with adhesive, black L = 1.3 m	1
8	0023-3010	Textile glass 6 mm with adhesive, black L = 0.36 m	1
9	0030-005956	Stove door	1
10	1013-0432	Glass clips - small	4
11	000-019440	Handle, completet	2
12	6000-027465	Complete handle for shaker	1

Parts - Glass door

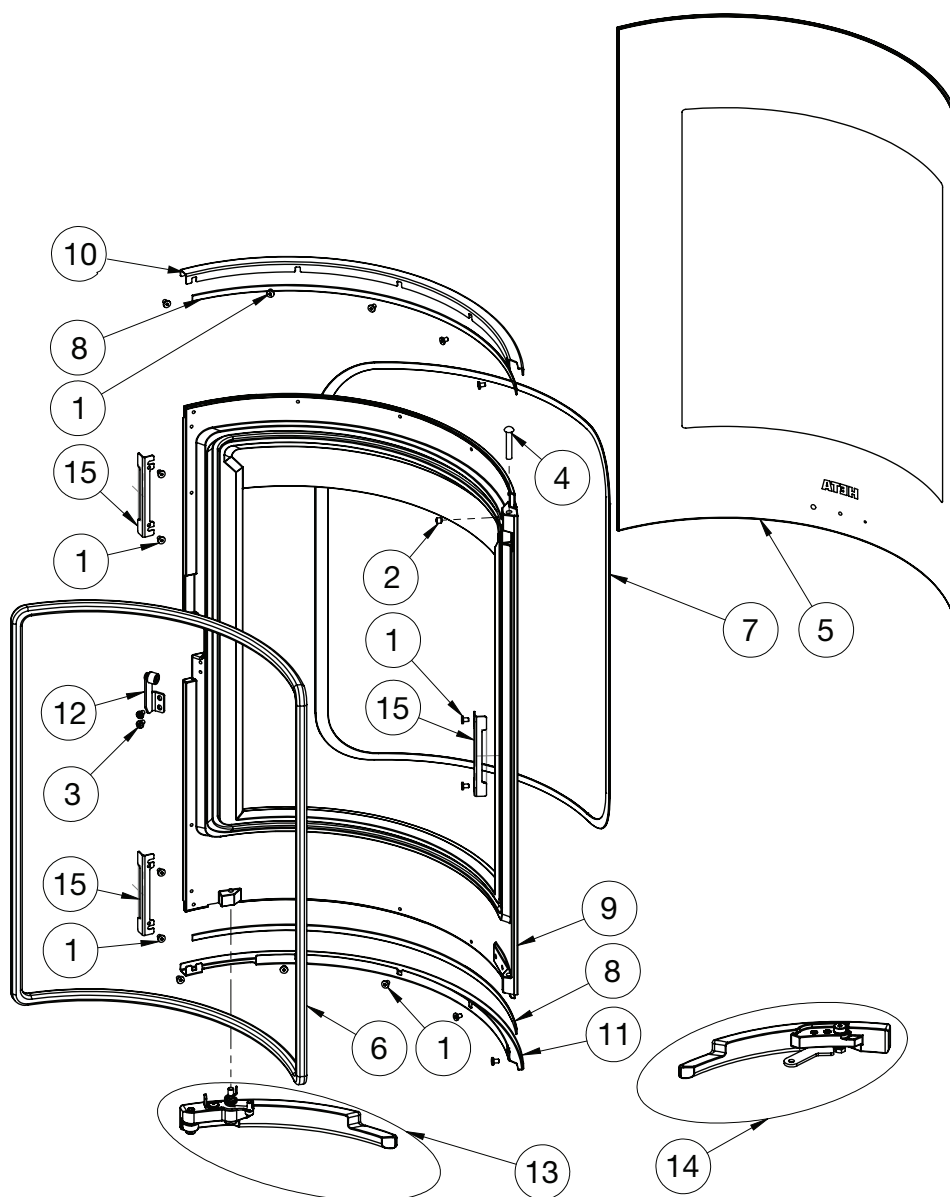

Pos.	No.	Name	Qty.
1	0008-0036	M4x6 Hexagon socket cap screw	16
2	0008-1002	M6x6 Hexagon socket set screw	1
3	0008-2304	M4x6 Hexalobular socket pan head	2
4	0008-9082	6x35 Round head rivet	1
5	0021-006557	Glass for stove door	1
6	0023-3008	Glass gasket \varnothing 12 soft L = 1.84 m	1
7	0023-3010	Textile glass 6 mm, with adhesive, L = 1.75 m	1
8	0023-3013	3x8 Glassband, L = 0.48 m	2
9	0030-008095	Stove door, glass	1
10	1013-019522	Glass strip top, glass front	1
11	1013-019564	Glass strip bottom, glass front	1
12	6000-005970	Close roller, completet, bottom	1
13	6000-020399	Handle, completet, door, glass front	1
14	6000-027465	Complete handle for shaker	1
15	1013-027825	Stop bracket for glass front	3

Parts - Baking oven door

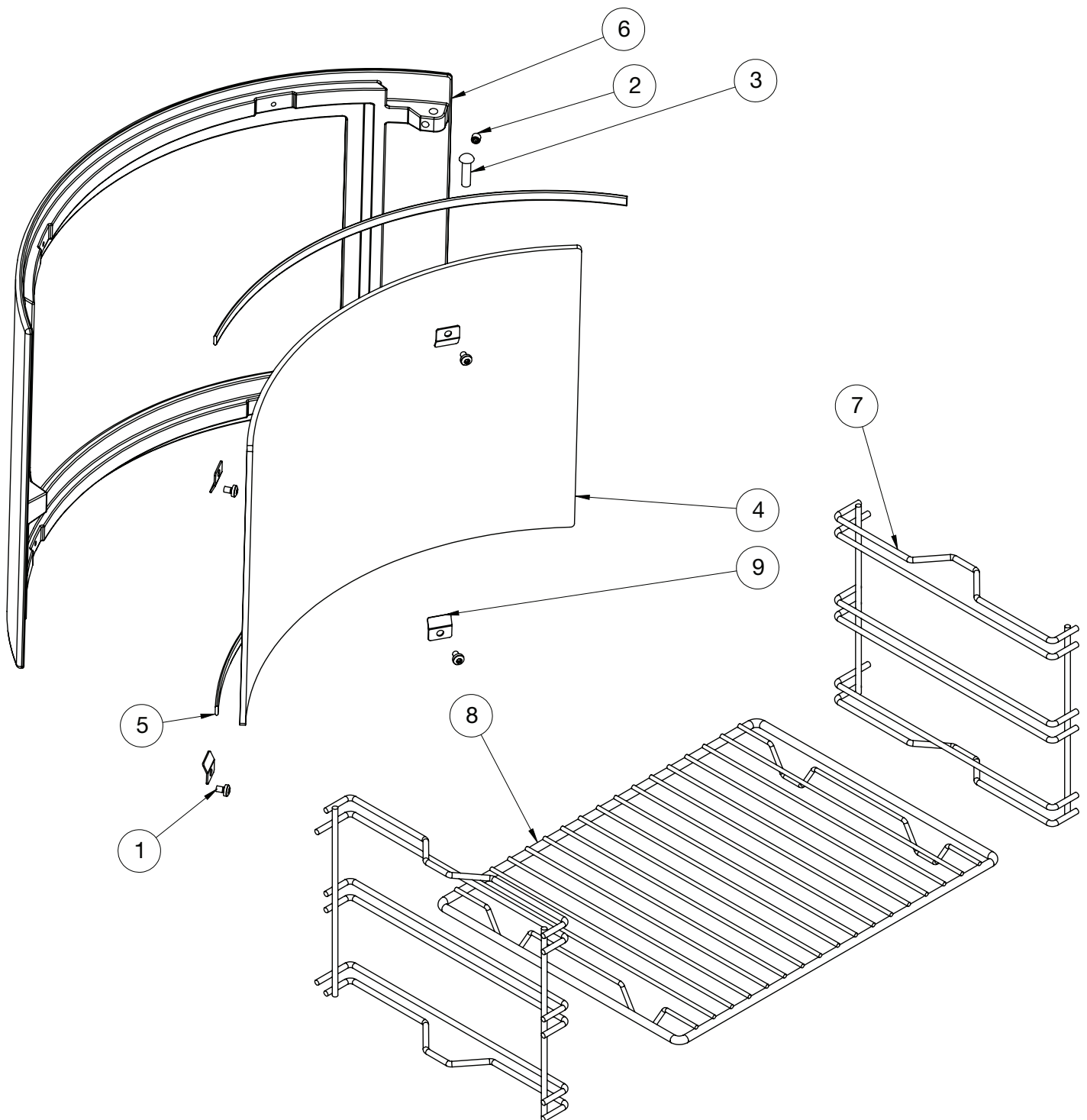

Pos.	No.	Name	Qty.
1	0008-0036	M4x6 With flat head	4
2	0008-1002	Set screw	2
3	0008-018935	Round head rivet steel	2
4	0021-020355	Glass	1
5	0023-3010	Glass gasket	
		Textile glass 6 mm, with adhesive, black L=0.36 m	2
6	0030-019579	Baking oven door	1
7	0050-0301	Rails for baking racks	2
8	0050-0302	Baking racks	1
9	1013-0432	Glass clips	4

Installation Instructions Contents

2.	Installation instructions	22
2.1	Distance requirements	22
2.2	Floor	23
2.3	Chimney connection	23
2.4	Combustion air and ventilation	24
2.5	Stovedrawings/measurments	24-26
2.6	Assembling the thermal stones.....	26
2.7	Connecting direct air below or behind.....	28
2.8	Installing the HAC unit.....	28
2.9	Clearances for installation EN 13 240	29
2.10	Changing to a back flue outlet	30
2.11	Door stop location.....	30
	EU Declaration of Conformity.....	31-32

Remember

The stove and chimney installation, must comply with local regulations, including those referring to national and European standards.

2. Installation instructions

The stove installation must be in accordance with national, European and possibly local regulations. You must follow local regulations with regard to installation of chimney and connection to the chimney. We recommend that you let a professional Heta dealer install the stove. Alternatively, you can ask the local chimney sweep before installation. Be aware that it is always the owner himself who has responsibility for ensuring that applicable rules are complied with.

A modern stove places heavy demands on the chimney due to the high efficiency. It may be necessary to enhance or even replace an old chimney.

Remember

1. Always ensure free access to any cleaning doors in a chimney.
2. Always ensure ample fresh air to the room.

3. Exhaust/extraction fans in the house can reduce or create negative draft in the chimney. Reduced draft can lead to the stove having adverse combustion properties. It may result in smoke coming out of the stove when the door is open. A negative draft due to an exhaust/extraction fan can cause the chimney to work in reverse, drawing smoke into the house because of the fan.
4. Any air vents must not be covered.

2.1 Distance Provisions

There is a difference between installation next to flammable wall or non-flammable wall. If the wall is made of non-flammable material, the stove in principle may be placed flush against it.

We recommend a minimum of 5 cm to facilitate air circulation around the stove.

The minimum distance to combustibles can be found on the model plate provided with the stove or on page 16 of this manual.

2.2 Floor

You must ensure that the floor can support the weight of the stove and a top-mounted steel chimney.

In front of the fireplace stove, the substrate must consist of non-combustible material, for ex. Steel/glass plate, stone or tile floor. The size of the non-combustible surface must follow the applicable national and local regulations, and must protect against any impact from embers that might fall out of the stove. Protecting your floor from embers that may fall out of the oven.

Distances see data table page 16.

2.3 The chimney connection

The chimney opening must follow national and local regulations. However, the area of the opening should never be less than 175 cm², which corresponds to a diameter of 150 mm. If a damper is fitted in the flue gas pipe, there must always be at least 20 cm² of free passage, even when the damper is in its “closed” position.

If local regulations permit, two contained stoves can be connected to the same chimney. However, you must abide by local regulations regarding the distance between the two connections.

The stove must never be connected to a chimney that is linked to a gas fire stove.

An efficient stove makes high demand on chimney properties – so always have your local chimney sweep evaluate your chimney.



Connection to a brick chimney

Brick a thimble into the chimney and seat the flue gas pipe in this.

The thimble and flue gas pipe must not penetrate the chimney opening itself, but must be flush with the inside of the chimney duct. Joins between brickwork, the thimble and flue gas pipe

must be sealed with fireproof material and / or beading. Heta A/S stresses that it is of utmost importance that this is done correctly with very tight joints. As mentioned earlier, we recommend that setup and installation be left to a professional Heta dealer.

Connection to a steel chimney

When fitting a connection from a top outlet stove directly to a steel chimney, we recommend fitting the chimney tube inside the flue gas spigot so that any soot and condensation drops into the stove itself rather than collecting on the exterior surface of the stove. For connections to chimneys that are run through ceilings, all national and local regulations regarding distance to flammable material must be followed. It is important that the chimney is fitted with roof support so that the top panel of the stove is not required to bear the entire weight of the chimney (excessive weight may damage the stove).

2.4

Combustion air and Ventilation

The stove is approved as a room air dependent stove in accordance with EN 13240. All the combustion air in the inset stove comes from the room in which it is fitted. However, by connecting a sealed air inlet to the stove’s air intake connector, the stove can be supplied with external combustion air. In this respect, the following requirements must be met:

- Only approved materials may be used from the ventilation unit to the air inlet vent.
- The air inlet vent must be fitted correctly and insulated to prevent formation of condensate. The cross section of the vent and grille must be at least 78 cm².
- If the vent leads out into the open air, please note that the grille must be fitted with suitable wind protection. There must be no risk that the grille can get clogged by leaves, etc.
- The stove has been tested with 3 m of 100 mm pipe, with 3 90 degree bends.

Ventilation

Adequate ventilation must be provided in accordance with building regulations (Doc J Oct 2010) especially when installing in newer build properties when the stove is not going to be installed to an outside air supply.

The Scan-Line 900 and Scan-Line 900 side windows (6.6 kW) requires the additional ventilation, when not connected to direct air, because it has a greater output than 5 kW.

The Scan-Line 900 series and Scan-Line 900 Side windows series have a nominal output of less than 6.6 kW and does not need additional

ventilation in older properties where it will be ventilated by natural leakage.

Houses built after 2008 where the air leakage rate is less than than 5 m³/ hour / m² then a ventilator equivalent to 550 mm² per kW output will be required (4.5 kW x 550 mm = 2475 mm²) unless the stove is connected to an outside fresh air supply.

Appendix A

The Clean Air Act 1993 and Smoke Control Areas.

Under the Clean Air Act local authorities may declare the whole or part of the district of the authority to be a smoke control area. It is an offence to emit smoke from a chimney of a building, from a furnace or from any fixed boiler if located in a designated smoke control area. It is also an offence to acquire an "unauthorized fuel" for use within a smoke control area unless it is used in an "exempt" appliance ("exempted" from the controls which generally apply in the smoke control area).

In England appliances are exempted by publication on a list by the Secretary of State in accordance with changes made to sections 20 and 21 of the Clean Air Act 1993 by section 15 of the Deregulation Act 2015. Similarly, in Scotland appliances are exempted by publication on a list by

Scottish Ministers under section 50 of the Regulatory Reform (Scotland) Act 2014. In Wales and Northern Ireland these are authorized by regulations made by Welsh Ministers and by the Department of the Environment respectively.

Further information on the requirements of the Clean Air Act can be found here:

<https://www.gov.uk/smoke-control-area-rules>

Your local authority is responsible for implementing the Clean Air Act 1993 including designation and supervision of smoke control areas and you can contact them for details of Clean Air Act requirements

The Scan-Line 900 with and without side windows have all been recommended as suitable for use in smoke control areas when burning dry wood logs.

2.5 Stovedrawings/measurments

Scan-Line 900 series

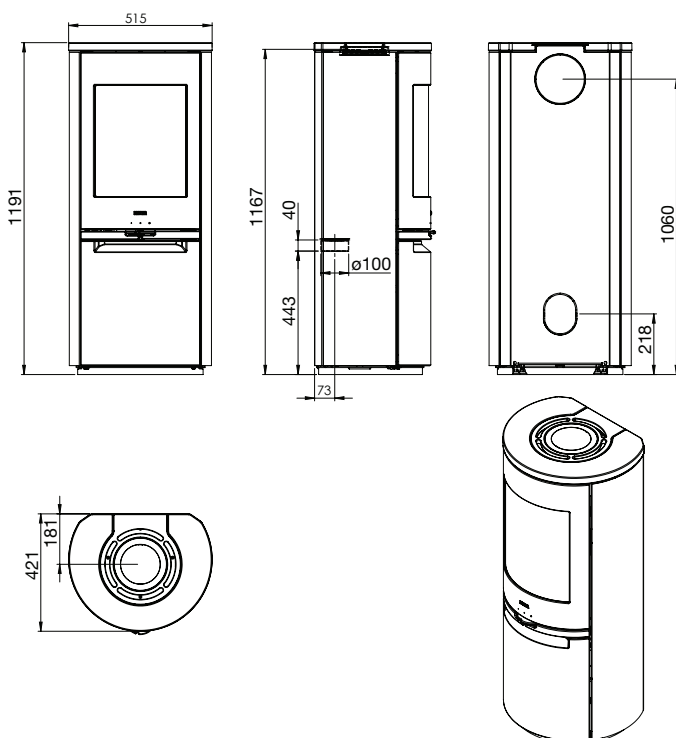

Scan-Line 900 Stone series

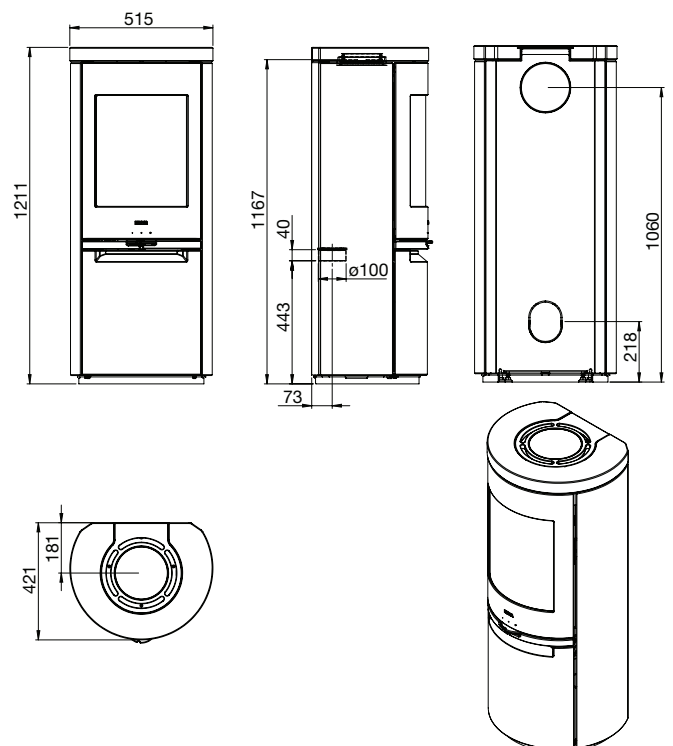

Scan-Line 900 Side windows series

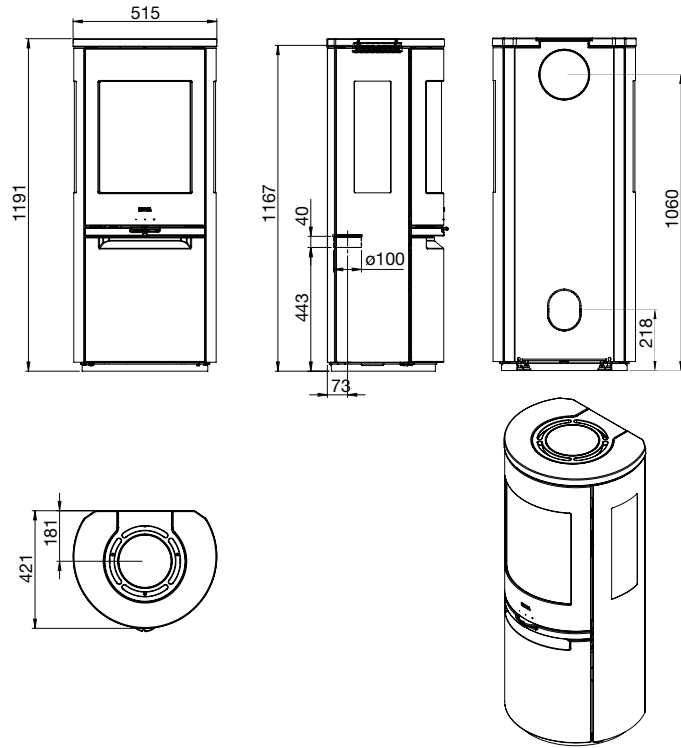

Scan-Line 900 Stone Side windows series

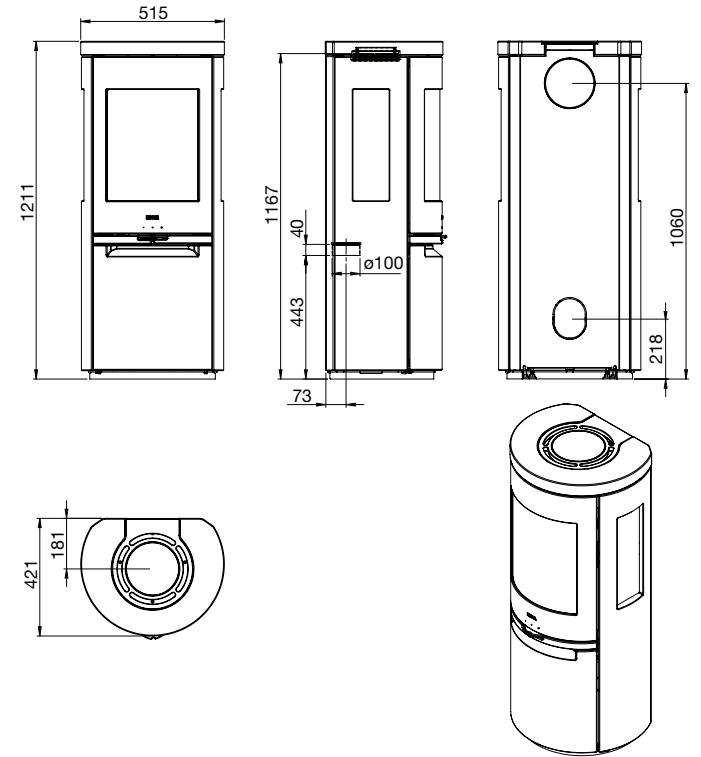

Scan-Line 900 S series

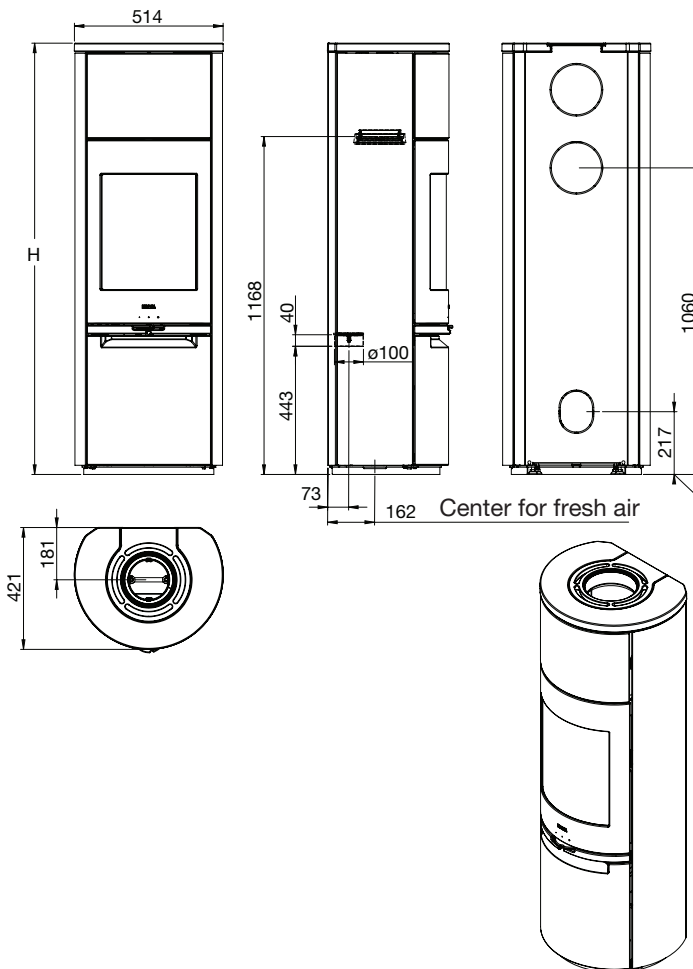

Scan-Line 900 B series

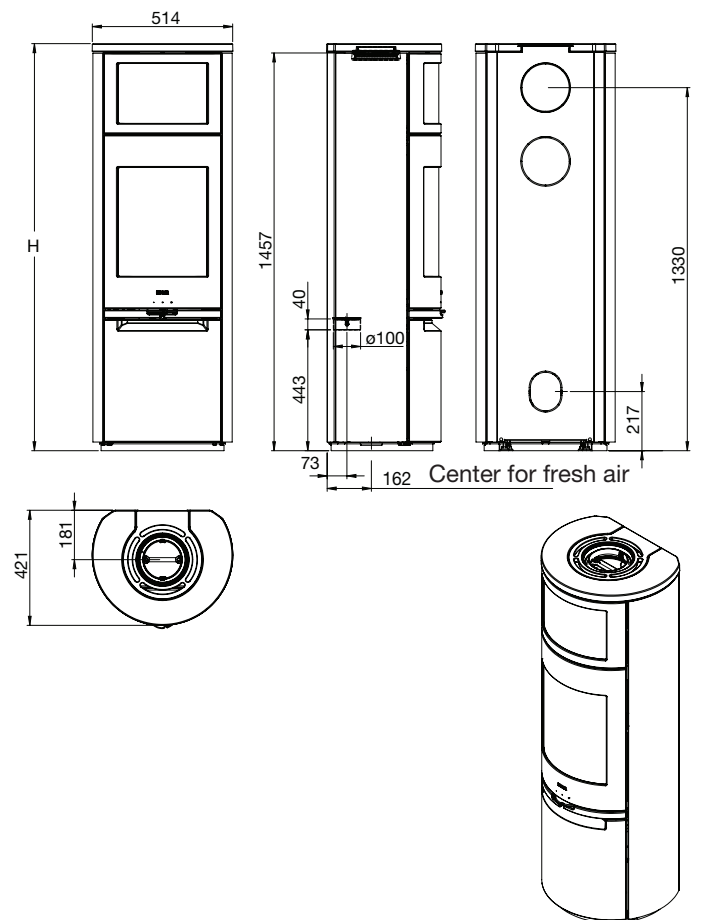

	Casted top	Stone top
H	1491	1511

	Casted top	Stone top
H	1491	1511

Scan-Line 900 S Side windows series

Scan-Line 900 B Side windows series

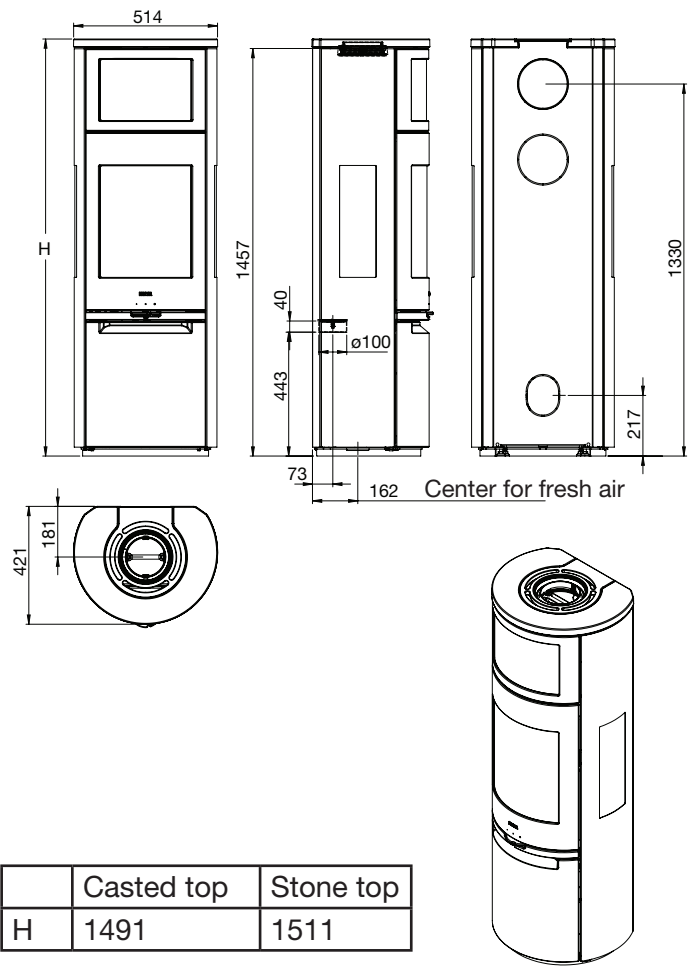
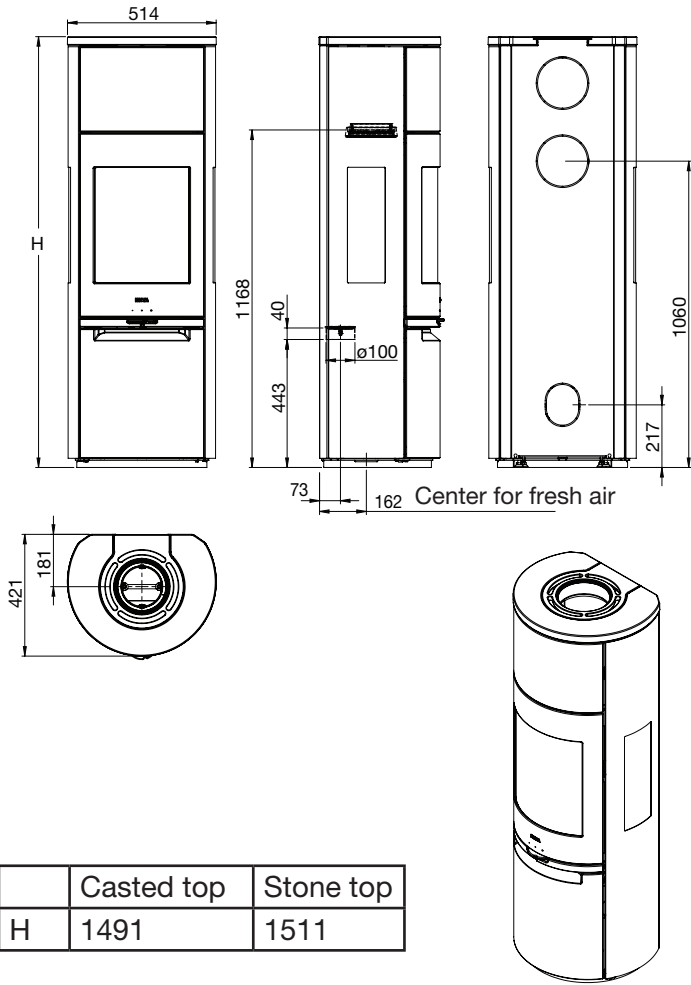

3.6 Assembling the thermal stones

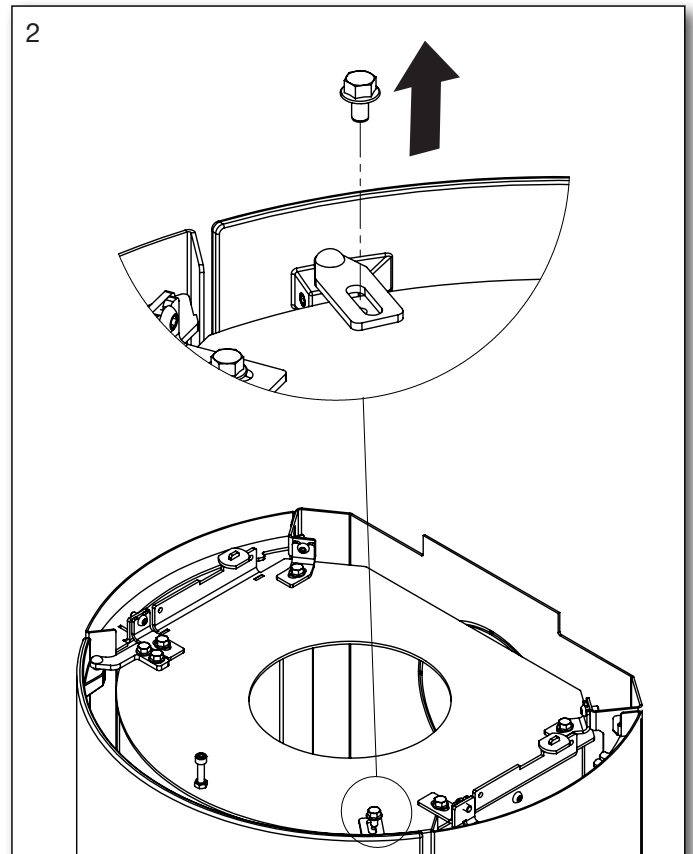
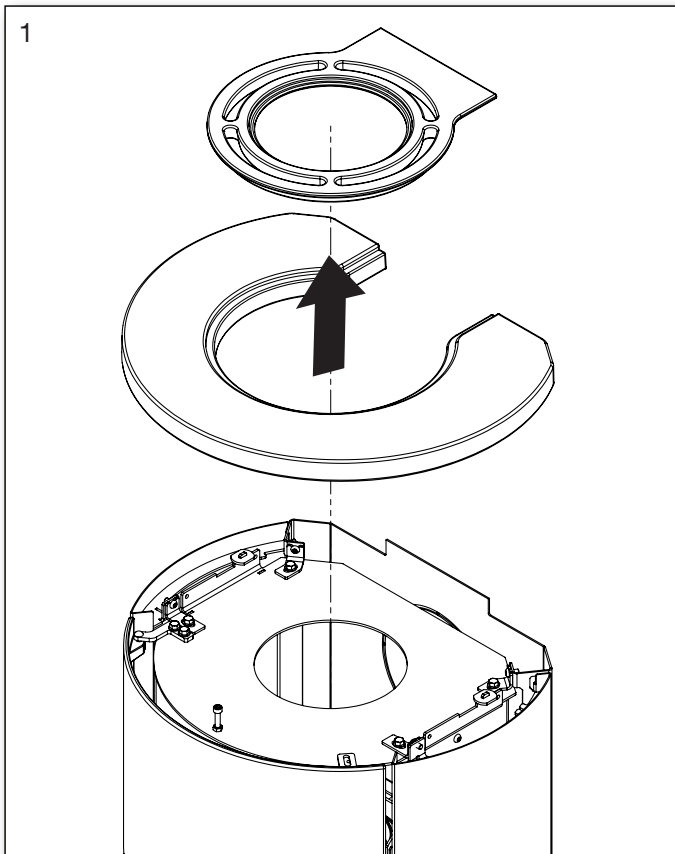

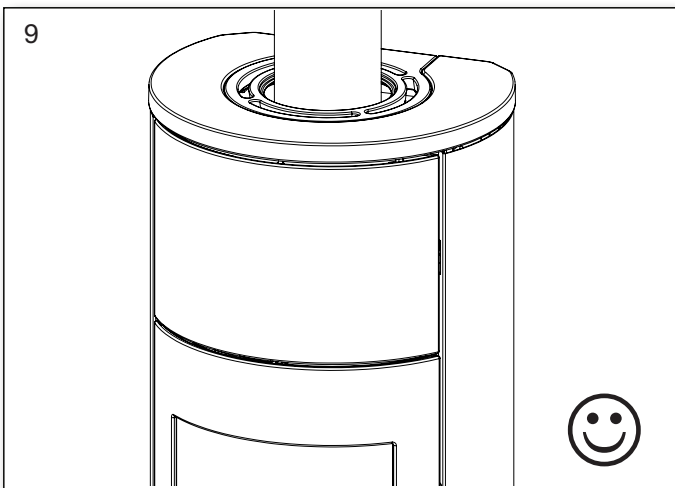
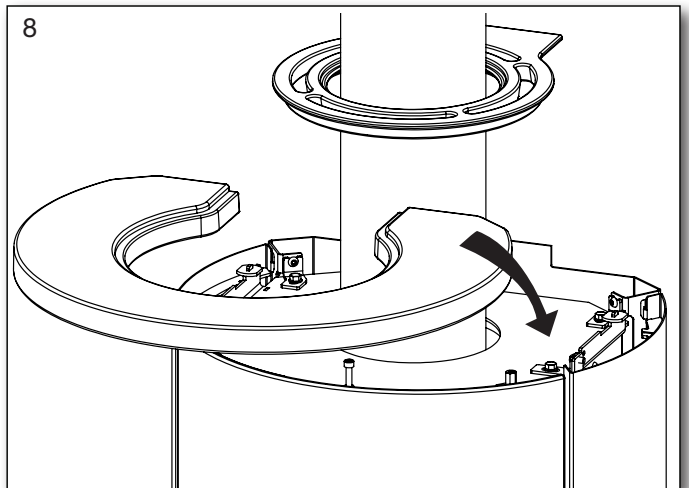
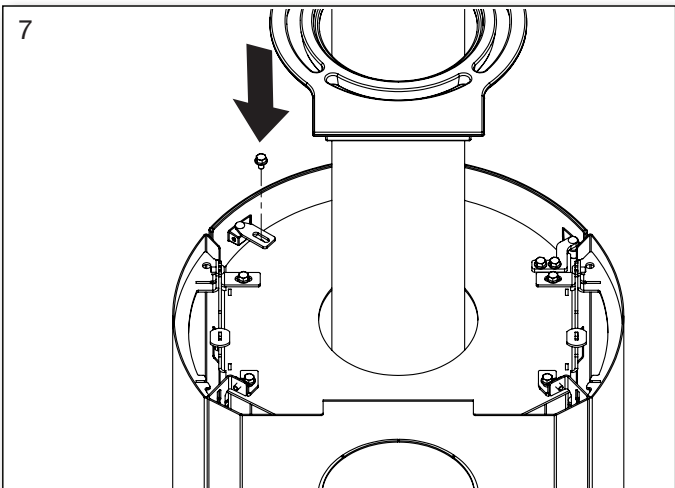
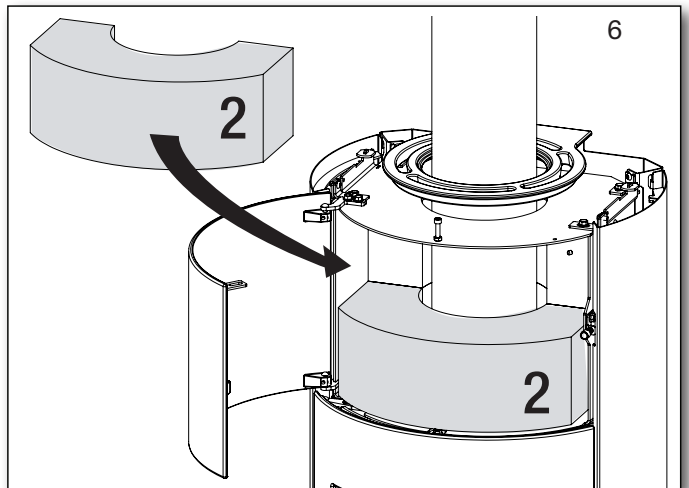
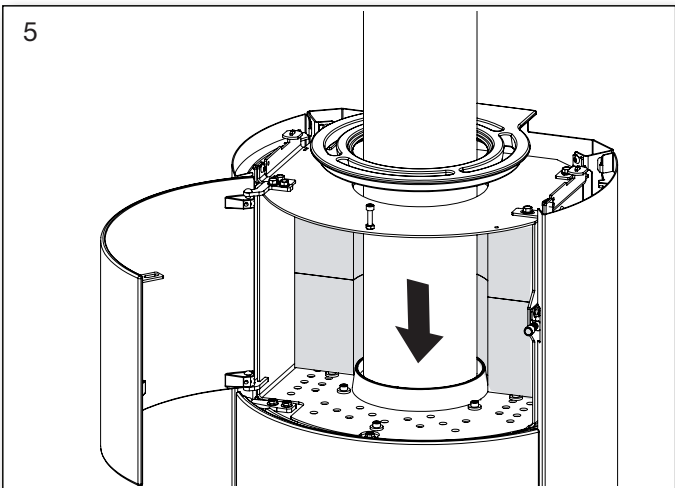
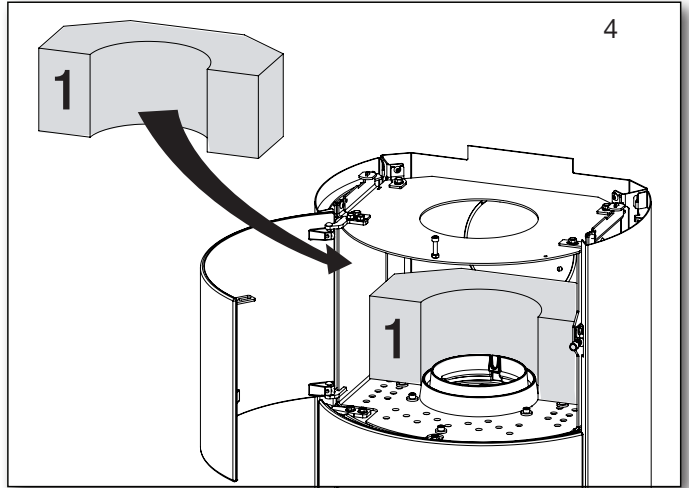
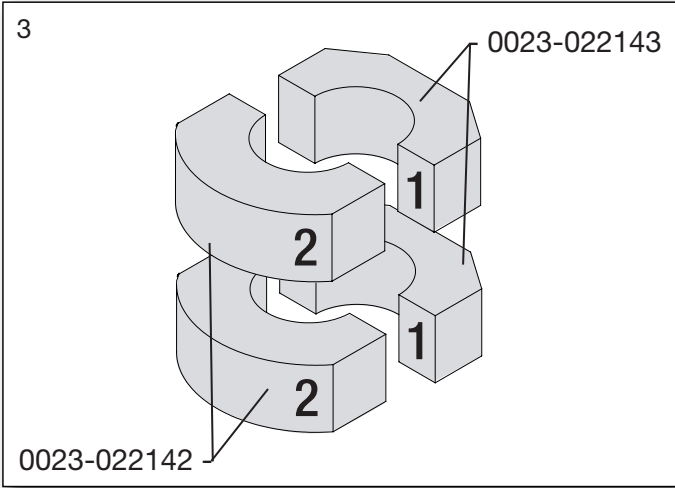

3.7 Connecting direct air below or behind

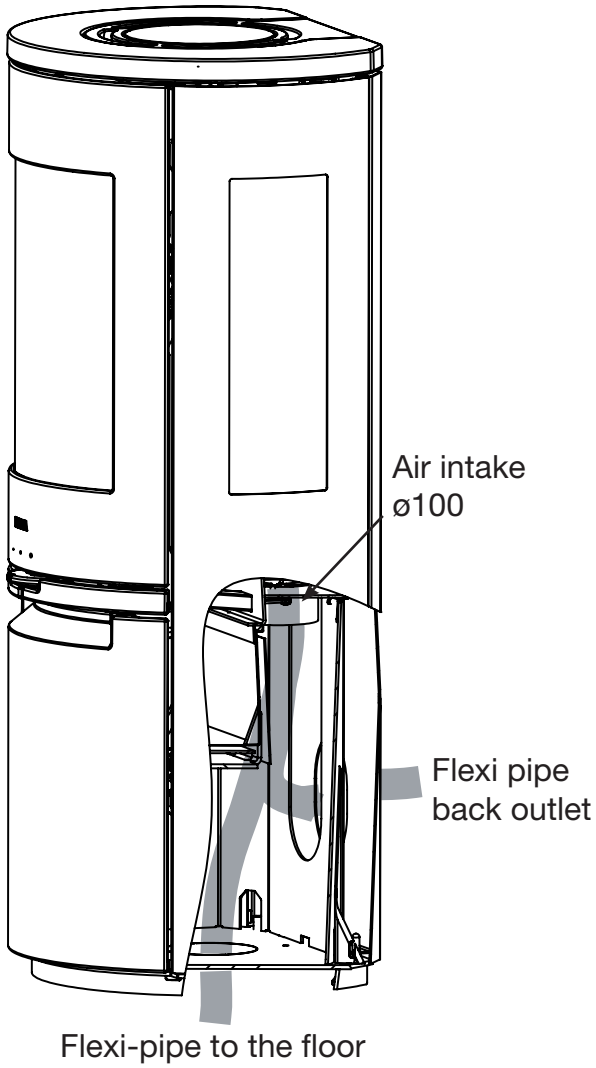

When installing external air supply, connect the air intake to the direct air pipe using flexi-pipe, both from the floor or behind the stove.

Flexi-pipe not included.

Direct air supply

The dimensions of the direct air supply pipe, may not be less than $\varnothing 100$ mm, the draught in the flue depends on this air for optimal combustion.

Heta recommends max. 4 meters of direct air pipe, with max. 3, 90° bends and a min. of $\varnothing 100$ mm.

3.8 Installing the HAC unit

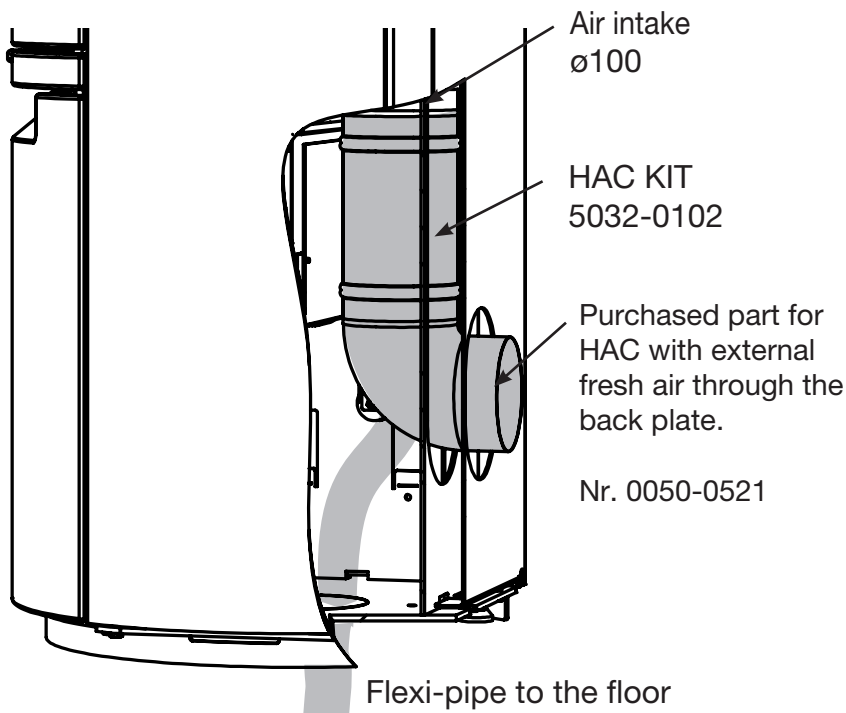

HAC motor position.

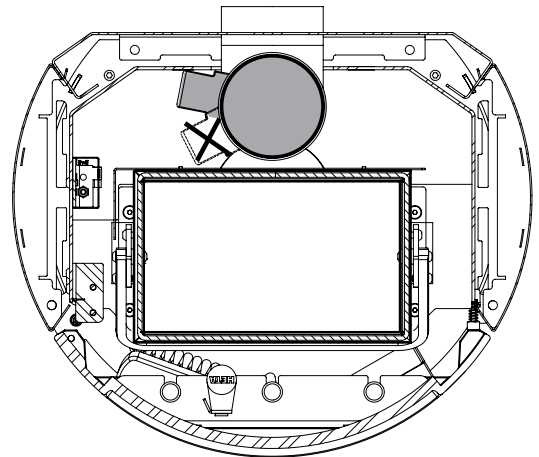

3.9 Clearances for installation EN 13 240 SL 900 series

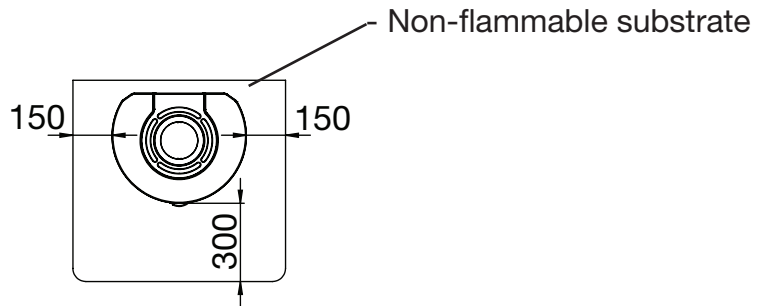
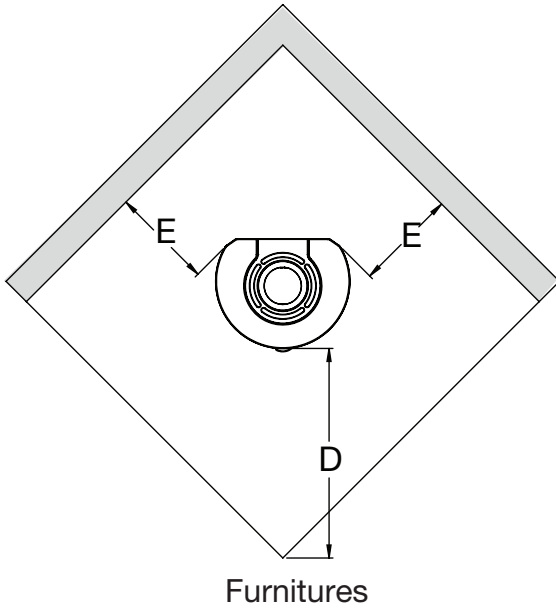
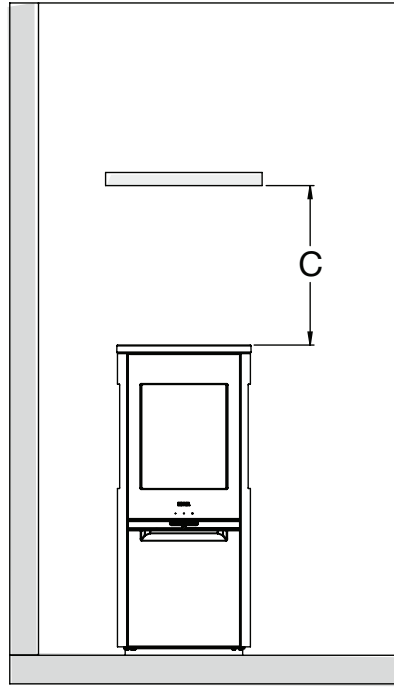
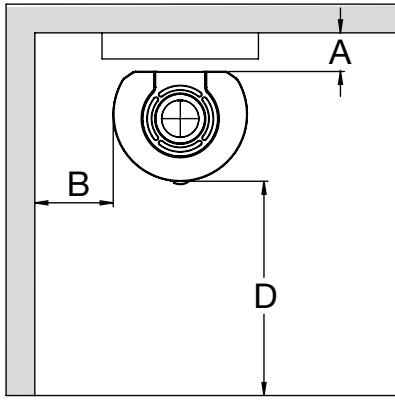

The dimensions are the minimum dimensions, unless otherwise stated.

Norwegian fire wall

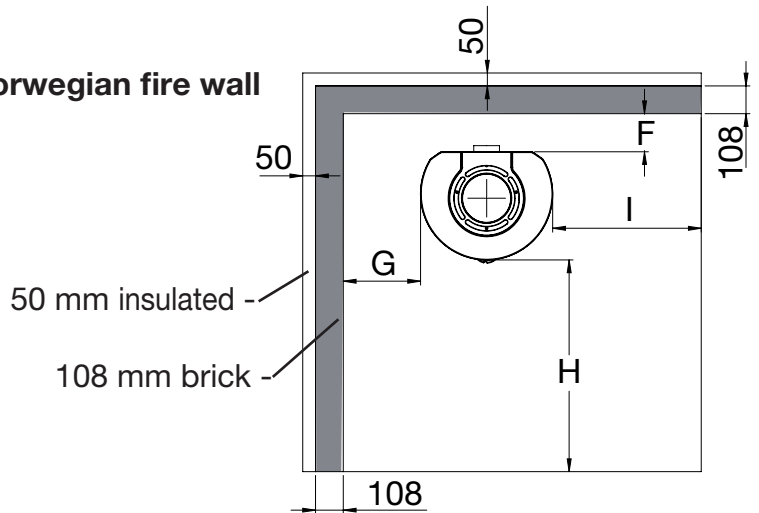

Clearances

Overtyp Stove	Distance from oven to combustable material					Norwegian fire wall Distance to firewall with 108 mm brick			
	A Rear the stove insulated / uninsulated flue pipe	B At the side	C Over oven	D To furnitures	E Corner distance	F Rear the stove uninsulated flue pipe	G At the side uninsulated flue pipe	H Length of fire wall forward in front of oven	I Length of fire wall next to oven
Scan-Line 900 series	175/175	350	390	1000	100	50	150	500	100
Scan-Line 900 Side windows series	125/150	400	390	900	200	50	200	400	200

3.10 Changing to a back outlet - Steel model with casted top

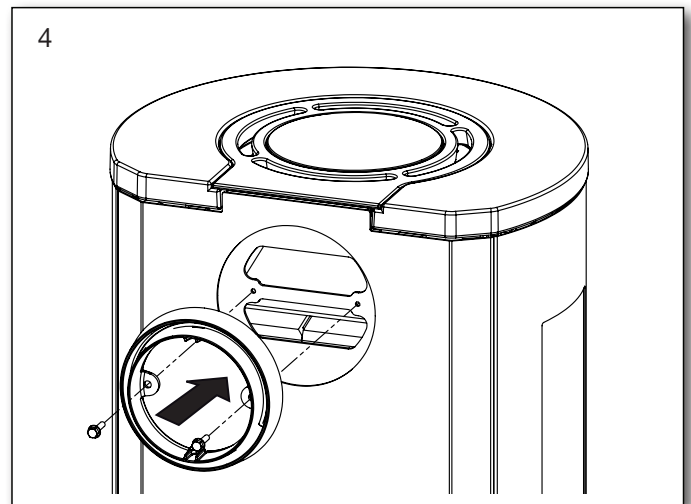
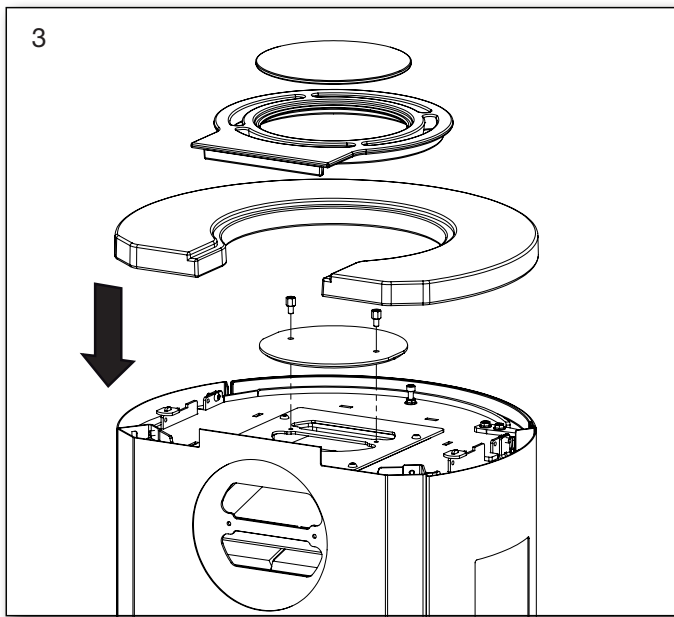
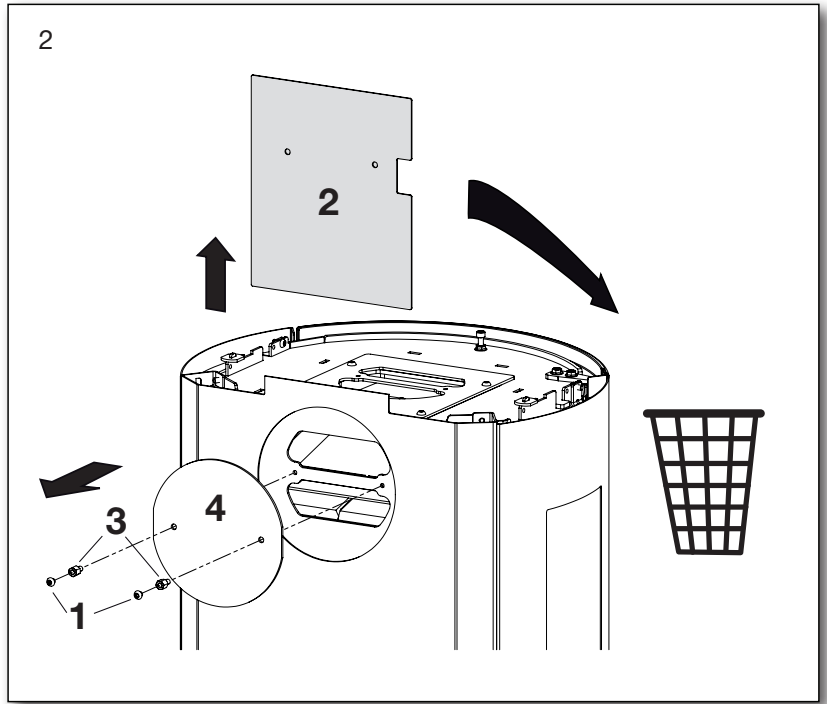
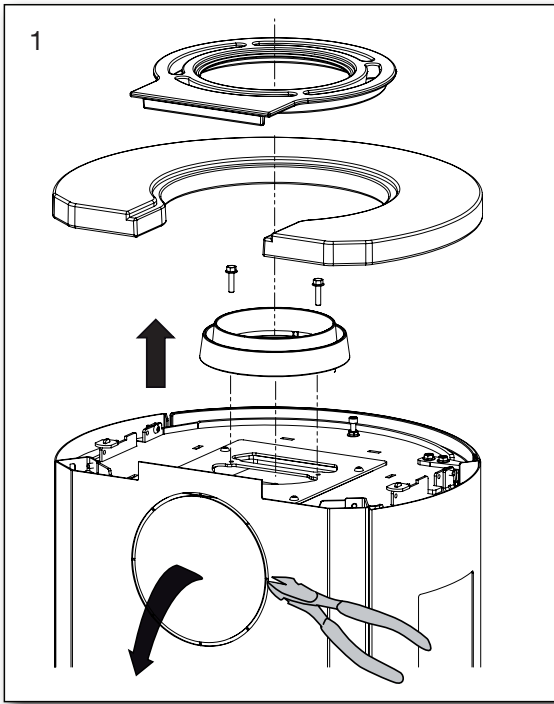

3.11 Door stop location

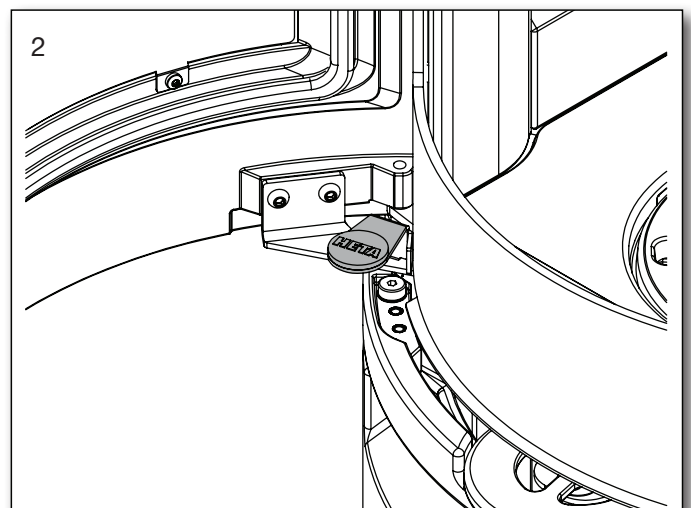
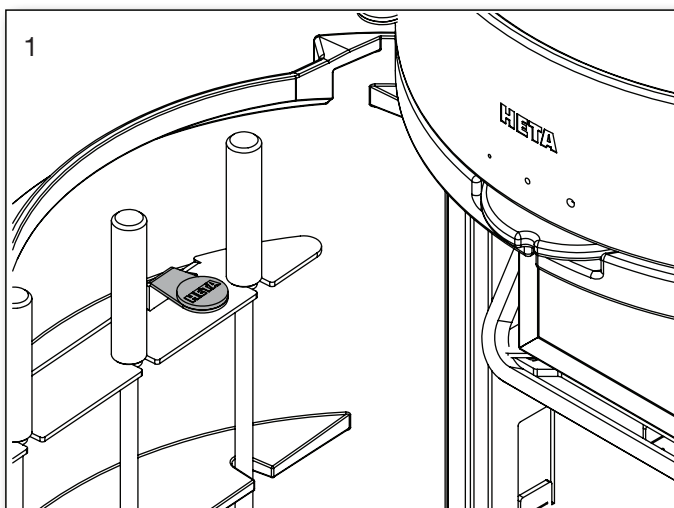

Manufacturer	Heta A/S
Adress	Jupitervej 22, DK 7620 Lemvig
E-mail	heta@heta.dk
Website	www.heta.dk
Telephone	+45 9663 0600

Ecodesign EU Declaration of Conformity

DoC Scan-Line 900 2409-2019

Product fiche



Model identifier	Scan-Line 900, 900B, 900S serie
-------------------------	---------------------------------

The identified product described above is in conformity with:
The relevant EU harmonized regulations:
DIR 2009/125/EF
REG (EU) 2015/1185
REG (EU) 2015/1186
REG (EU) 2017/1369
REG (EU) 305/2011
The relevant harmonized standards
EN 13240:2001/A2:2004
CEN/TS 15883:2010

Characteristics when operating with the preferred fuel only		
Heat output		
Item	Symbol	Value/Unit
Nominal heat output	P_{nom}	6,8 kW
Minimum heat output	P_{min}	
Useful efficiency (NCV as received)		
Useful efficiency at nominal heat output	$\eta_{th, nom}$	83%
Useful efficiency at minimum heat output	$\eta_{th, min}$	
Auxiliary electricity consumption		
At nominal heat output	$e_{l, max}$	- kW
At minimum heat output	$e_{l, min}$	- kW
In standby mode	$e_{l, SB}$	- kW

Type of heat output/room temperature control	
single stage heat output, no room temperature control	Yes
two or more manual stages, no room temperature control	No
with electronic room temperature control	No
with electronic room temperature control plus day timer	No
with electronic room temperature control plus week timer	No

Other control options	
room temperature control, with presence detection	No
room temperature control, with open window detection	No
with distance control option	No

Notified body relevant to the assessment and verification of constancy of performance
Danish Technological Institute, DK-8000 Aarhus No. 1235. Report no. 300-ELAB-2409-EN

Fuel	Preferred fuel	Other suitable fuel
Wood logs with moisture content $\leq 25\%$	Yes	No
Compressed wood with moisture content $< 12\%$	No	No
Other woody biomass	No	No
Non-woody biomass	No	No
Anthracite and dry steam coal	No	No
Hard coke	No	No
Low temperature coke	No	No
Bituminous coal	No	No
Lignite briquettes	No	No
Peat briquettes	No	No
Blended fossil fuel briquettes	No	No
Blended biomass and fossil fuel briquettes	No	No
Other blend of biomass and solid fuel	No	No

Emissions at nominal heat output	η_s %	mg/Nm ³ (13 % O ₂)			
		PM	OGC	CO	NO _x
	≥ 65	≤ 40	≤ 120	≤ 1500	≤ 200
	73	9	44	591	91

Technical documentation	
Indirect heating functionality:	No
Direct heat output:	6,8 kW
Energy Efficiency Index (EEI):	EEI 110
Fluegas temperature at nominal heat output	T 251°C
Energy efficiency class	

Safety	
Reaction to fire	A1
Test of fire safety in connection with the burning of wood	Approved
Distance to combustible materials Rear. Without insulation / with insulation	Minimum distances in mm 175/175
Sides distance to combustible materials	350
Furniture distance	1000

Signed on behalf the manufacturer of 07.02.2022

The chimney sweep's signature Date _____

 JUPITERVEJ 22 · DK-7620 LEMVIG
 TLF. +45 9663 0600 · FAX +45 9663 0616
 Martin Bach

Signature _____



Ecodesign EU Declaration of Conformity

DoC Scan-Line 900 2408-2019

Product fiche



Manufacturer	Heta A/S
Adress	Jupitervej 22, DK 7620 Lemvig
E-mail	heta@heta.dk
Website	www.heta.dk
Telephone	+45 9663 0600

Model identifier	Scan-Line 900 Side windows, 900B Side windows, 900S Side windows Series
-------------------------	---

The identified product described above is in conformity with:
The relevant EU harmonized regulations:
DIR 2009/125/EF
REG (EU) 2015/1185
REG (EU) 2015/1186
REG (EU) 2017/1369
REG (EU) 305/2011
The relevant harmonized standards
EN 13240:2001/A2:2004
CEN/TS 15883:2010

Characteristics when operating with the preferred fuel only		
Heat output		
Item	Symbol	Value/Unit
Nominal heat output	P_{nom}	6,6 kW
Minimum heat output	P_{min}	
Useful efficiency (NCV as received)		
Useful efficiency at nominal heat output	$\eta_{th, nom}$	82%
Useful efficiency at minimum heat output	$\eta_{th, min}$	
Auxiliary electricity consumption		
At nominal heat output	el_{max}	- kW
At minimum heat output	el_{min}	- kW
In standby mode	el_{SB}	- kW

Type of heat output/room temperature control	
single stage heat output, no room temperature control	Yes
two or more manual stages, no room temperature control	No
with electronic room temperature control	No
with electronic room temperature control	No
with electronic room temperature control plus day timer	No
with electronic room temperature control plus week timer	No

Other control options	
room temperature control, with presence detection	No
room temperature control, with open window detection	No
with distance control option	No

Notified body relevant to the assessment and verification of constancy of performance
Danish Technological Institute, DK-8000 Aarhus No. 1235. Report no. 300-ELAB-2408-EN

Fuel	Preferred fuel	Other suitable fuel
Wood logs with moisture content $\leq 25\%$	Yes	No
Compressed wood with moisture content $< 12\%$	No	No
Other woody biomass	No	No
Non-woody biomass	No	No
Anthracite and dry steam coal	No	No
Hard coke	No	No
Low temperature coke	No	No
Bituminous coal	No	No
Lignite briquettes	No	No
Peat briquettes	No	No
Blended fossil fuel briquettes	No	No
Blended biomass and fossil fuel briquettes	No	No
Other blend of biomass and solid fuel	No	No

Emissions at nominal heat output	$\eta_s\%$	mg/Nm ³ (13 % O ₂)			
		PM	OGC	CO	NO _x
	≥ 65	≤ 40	≤ 120	≤ 1500	≤ 200
	72	9	113	1244	76

Technical documentation	
Indirect heating functionality:	No
Direct heat output:	6,6 kW
Energy Efficiency Index (EEI):	EEI 109
Fluegas temperature at nominal heat output	T 265°C
Energy efficiency class	

Safety	
Reaction to fire	A1
Test of fire safety in connection with the burning of wood	Approved
Distance to combustible materials Rear. Without insulation / with insulation Sides distance to combustible materials Furniture distance	Minimum distances in mm 125/150 400 900

Signed on behalf the manufacturer of 07.02.2022

The chimney sweep's signature Date _____

Heta A/s
JUPITERVEJ 22 - DK-7620 LEMVIG
TLF. +45 9663 0600 - FAX +45 9663 0616
Martin Bach

Signature _____